

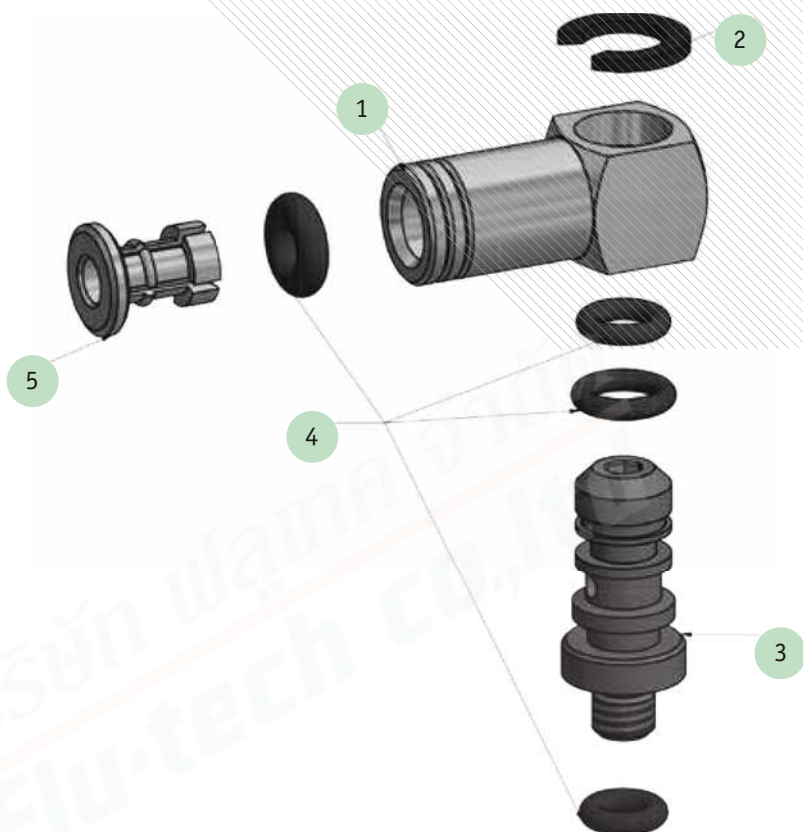

MINI

- 1 CORPO DEL RACCORDO
FITTING BODY
- 2 ANELLO ELASTICO
ELASTIC RING
- 3 ASTINA GIREVOLE
SWIVEL STEM
- 4 O-RING DI TENUTA
O-RING SEAL
- 5 ANELLO SPINGITORE E AGGRAFFAGGIO
THRUST AND CRIMPING SLEEVE



ART. RDR

Diritto filetto cilindrico maschio con O-Ring
Straight male adaptor (parallel)

CODICE	D	G	C	H	L		⊙	▣
RDR3.20	2,0	M3	5,4	3	13,5		1,5	100
RDR3.30	3,0	M3	5,8	3	14,5		1,5	100
RDR3.31	3,17	M3	5,8	3	14,0		1,5	100
RDR3.40	4,0	M3	7,0	3	15,5		1,5	100
RDR3.40-MH05	4,0	M3	6,9	5	17,5		1,5	100
RDR5.20	2,0	M5	5,4	3,5	13,0		1,5	100
RDR5.30	3,0	M5	5,8	3,5	14,5		2,0	100
RDR5.31	3,17	M5	5,8	3,5	14,5		2,0	100
RDR5.40	4,0	M5	5,8	3,5	16,5		2,0	100
RDR6.40-FH12	4,0	M6	7	12	24,5		2,0	100
RDR6.40-MH12	4,0	M6	7	12	24,5		2,0	100

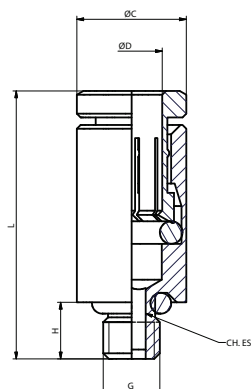

ART. RGR

Asta con filetto cilindrico in anello semplice
Complete single banjo with stem

CODICE	D	G	C	H	L	L1	⊙	▣
RGR3.20	2	M3	1,4	3,0	13,5	13,5	1,5	100
RGR3.30	3	M3	1,4	3,0	13,5	13,5	1,5	100
RGR3.31	3,17	M3	1,4	3,0	13,5	13,5	1,5	100
RGR3.40	4,2	M3	1,4	3,0	13,5	13,5	1,5	100
RGR3.40-MH05	4,2	M3	1,4	5,0	13,5	13,5	1,5	100
RGR5.20	2	M5	2,0	3,5	14	14	2,0	100
RGR5.30	3	M5	2,0	3,5	14	14	2,0	100
RGR5.31	3,2	M5	2,0	3,5	13,5	13,5	2,0	100
RGR5.40	4,2	M5	2,0	3,5	13,5	13,5	2,0	100
RGR6.40-FH12	4,2	M6	2,0	12	13,5	13,5	2,0	100
RGR6.40-MH12	4,0	M6	2,0	12	13,5	13,5	2,0	100

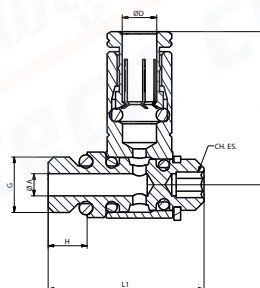

ART. RDSR

Diritto maschio cilindrico con scarico rapido
Quick exhaust straight male parallel adapter

CODICE	L	ØC	ØD	G	H		⊙	▣
RDSR520	18,5	6,8	2,0	M5	3,5		7	100
RDSR530	18,5	6,8	3,0	M5	3,5		7	100
RDSR531	18,3	6,8	3,0	M5	3,5		7	100
RDSR540	19,5	7,8	4,2	M5	3,5		8	100

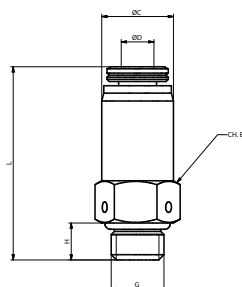

ART. RGSR

Gomito girevole cilindrico con scarico rapido
Quick exhaust swivel L parallel adapter

CODICE	ØB	ØD	H	H2	E	G	●	■
RGSR520	5,8	2,1	3,5	19	14	M5	7	100
RGSR530	5,8	3,0	3,5	19	14	M5	7	100
RGSR531	5,8	3,2	3,5	19	14	M5	7	100
RGSR540	5,8	4,2	3,5	19	14	M5	7	100

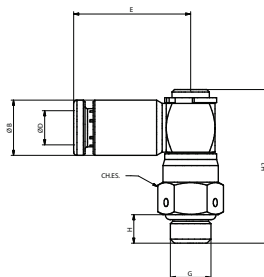

ART. RRR

Riduzione con codolo
Plug-in reducer

CODICE	ØD1	ØD2	ØB	L	■
RRR3020 *	2,0	3,2	5,8	23,2	100
RRR4020	4,0	2,0	5,8	25,5	100
RRR4030	4,0	3,0	5,8	25,5	100

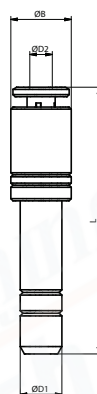

ART. RTR

T combinato intermedio
T combined connector

CODICE	ØC	L1	L2	G	H	ØB	ØA	L3	●	■
RTR020	2,10	13,7	12			5,8	5,8	3	6	100

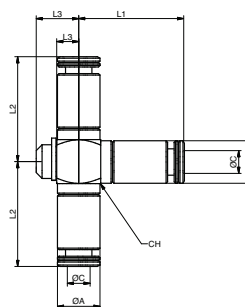

ART. RTR

T combinato filettato
T combined thread

CODICE	ØC	L1	L2	G	H	ØB	ØA	L3	●	■
RTR330	3,0	7,7	14	M3	3	5,8	5,8	5,8	6	100

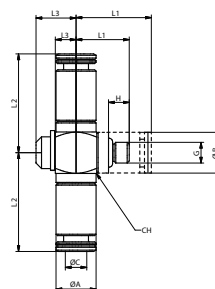

BREVE DESCRIZIONE

La serie dei raccordi MINI supercompatta, estremamente leggera ma robusta, si può innestare e disinnestare con una mano, ed è utilizzabile con tubi PA, TPU, Ny e PE. L'O-Ring è provvisto della propria sede per assicurare la tenuta su superfici pulite

SHORT DESCRIPTION

The MINI supercompact fittings series, extremely lightweight yet sturdy, can be inserted and extracted with one hand and it is suitable for tube PA, TPU, Ny and PE. The O-Ring is provided with his own seat to ensure seal with polished surface.

SCHEMA TECNICA TECHNICAL SHEET

FLUIDI UTILIZZABILI <i>EMPLOYABLE FLUIDS</i>		Aria compressa (per altri fluidi contattare il nostro Ufficio Tecnico) <i>Compressed air (for different fluid pls contact our Technical Dept.)</i>
APPLICAZIONI <i>APPLICATIONS</i>		Impianti pneumatici, idoneo anche per applicazioni con il vuoto. <i>BSP parallell UNI-ISO 228; BSP tapered UNI-ISO 7; Metric ISO/R 262</i>
TUBI CONSIGLIATI <i>SUGGESTED TUBES</i>		TPU (Poliuretano), PA11/PA12 (Poliammide), TPE (Polietilene), TCO (Copoliestere) <i>TPU (Polyurethane), PA11/PA12 (Polyamide), TPE (Polyethilene), TCO (Copolyester).</i>
FILETTATURE <i>THREAD TYPE</i>		Cilindrica con O-Ring. <i>Cylindrical with O-ring.</i>
VALORI LIMTE CONSIGLIATI <i>RECOMMENDED LIMIT VALUE</i>	COPPIA DI SERRAGGIO MASSIMA <i>MAXIMUM TORQUE</i>	Filettatura M3 = 0,4 Nm; Filettatura M6 e M6x0,75 = 1,3 Nm <i>Thread M3 = 0,4 Nm; Thread M6 and M6x0,75 = 1,3 Nm</i>
	TEMPERATURE <i>TEMPERATURES</i>	Le temperature di esercizio sono comprese fra -20°C e +70°C <i>The working temperatures range is between -20°C and +70°C</i>
	PRESSIONI <i>PRESSURES</i>	La pressione di esercizio massima è 10 bar <i>The maximum working pressure is 10 Bar.</i>
MATERIALI <i>MATERIALS</i>	CORPO <i>BODY</i>	Ottone nichelato <i>Nichel-plated</i>
	PINZA <i>GRIP</i>	Ottone <i>Brass</i>
	GUARNIZIONI TENUTA <i>SEALS</i>	NBR esenti da silicone <i>Silicon free NBR</i>
NOTE <i>NOTES</i>		Prodotto gestito direttamente da Pneumax S.p.a. <i>Product managed directly from Pneumax S.p.A</i>



1

ISTRUZIONI DI MONTAGGIO - FITTING INSTRUCTIONS

Prima dell'inserimento - Before the insertion

- Il tipo di tubo utilizzato deve essere dichiarato dal costruttore idoneo all'utilizzo con raccordi automatici
The type of employed pipe must be declared as suitable by the manufacturer to be used with push-in fittings
- Il taglio del tubo deve essere effettuato a 90° mediante apposita pinza taglia tubo (Vedi nostro catalogo bluline)
The cutting of the pipe must be at a right angle using a dedicated tube cutter (See our bluline catalogue)
- Non effettuare il taglio del tubo con forbici, tenaglie o altri utensili che possano conferire all'estremità del tubo estremità non lineari
Do not cut the hose with scissors, pincers or other tools that may cause non-linear surface to the end of the tube



2

INSERIMENTO CORRETTO DEL TUBO SUL RACCORDO CORRECT INSERTION OF THE HOSE IN THE FITTING



3

FOTO 1 - PICTURE 1

Tubo prima dell'inserimento - Hose before insertion

FOTO 2 - PICTURE 2

Tubo inserito - Inserted hose

FOTO 3 - PICTURE 3

Tubo tagliato a 90° con pinza in plastica - Tube tagliato a 90° con pinza



4

FOTO 4 - PICTURE 4

Tubo tagliato in modo corretto con pinza in metallo - Correct hose cut with metal tube cutter

Durante l'inserimento - During the insertion

- Effettuare una leggera rotazione del tubo in modo da agevolarne l'ingresso, assicurarsi di arrivare con il tubo fino a quota di battuta interna.
Turn the hose slightly so to make it easier to get in, make sure the pipe reach the inside stop.

Sgancio del tubo - Hose extraction

- Per effettuare lo sgancio del tubo, o disinnesto, premere il tappo spintore fino a battuta, mantenendo la pressione su quest'ultimo estrarre il tubo dal corpo (l'operazione può essere facilitata con l'utilizzo di apposita forchettina).
To extract the hose, or realising it, press the sleeve until it stops and keeping it pressed remove the tube from the fitting (the operation can be done easier using an appropriate fork).
- Assicurarsi che il tubo inserito non sia soggetto a trazione e che il tappo spintore non venga a contatto con nessun tipo di oggetto in modo da non generare sganci o sfilamenti involontari.
Make sure that the inserted hose is not under traction and that the sleeve does not run the risk of accidental contacts which may cause unintentional extraction or releasing.



5

FOTO 5 - PICTURE 5

Raccordo con tubo inserito e in trazione - Fitting with inserted hose, in tension.



6

FOTO 6 - PICTURE 6

Raccordo con tubo inserito avente raggio di curvatura stretto - Fitting with hose inserted, having a tight bending radius.