

# SUCTION CUPS

Pneumax suction cups are available in different shapes and materials, to meet the application requirements of the most demanding industrial sectors.



## Suction cup choice

### Suction cup Flat series TP

Suction cup to be used for moving sheets and in those applications where the lifting force is parallel to the gripping plane.

Internal reinforcements improve stability and make this cup suitable for handling heavy objects.

### Suction cup Bellows series TS

Suction cup best used in particular for moving light items in those applications where the lifting force is vertical to the gripping plane. The range of the bellows makes it possible to compensate for the irregularity of the surface and height of the object. The long bellows suction cup is best used in applications where it is necessary to pick off and move light products such as: leaves of paper or pieces of cardboard, thin sheets, wood panels, etc.

Due to their greater flexibility, these can be used to compensate for errors of flatness or to grip inclined surfaces, but are not suitable for applications with parallel loads or with a high degree of vacuum.

### Suction cup (Plain) Cup series TN

Among the most common types of suction cup, used in sectors of industry where special performance is not required: Handling of objects made of plastic, wood panels, thin sheets of glass and metal, etc. Recommended for vertical movement of heavy objects.

### High Grip suction cup

Suction cup with high coefficient of friction, developed for the handling of oily surfaces, such as sheet metal in moulding processes, and also recommended for handling wet marbles and glasses, slabs and loads in general, subject to high accelerations and decelerations during movement. Recommended for the "automotive" sector, available in various sizes and shapes: round and oval flat and round and oval bellows.

Suitable for horizontal and vertical movement.

### Foam rubber suction cups

This suction cup allows for the moving and gripping of loads with coarse, very rough or uneven surfaces, such as: textured, nonslip or ribbed/corrugated sheets, and sawn, bush-hammered or flamed marble. Items made of rough concrete, garden walkway tiles and brick in general. Recommended for use with oiled surfaces and to move vertical loads.



## Material choice

The material choice depend on the individual application, evaluating as follows:

- **Surface roughness of the load to be moved and its temperature.**
- **Weight and dimensions of the load.**
- **The presence of chemical substances, oils, solvents etc. on the gripping surface.**
- **How labour-intensive and complex the work processes are.**
- **How important it is to ensure that no specks exist on the gripping surface.**

## Suction cup characteristics and materials

Material	Temperature °C	Abrasion resistance	Oil resistance	Resistance to weather/atmospheric agents
<b>N</b> NBR	<b>-20 ... +110</b>	<b>Excellent</b>	<b>Excellent</b>	<b>Good</b>
<b>S</b> Silicone	<b>-40 ... +200</b>	<b>Good</b>	<b>Low</b>	<b>Excellent</b>
<b>PU</b> Polyurethane	<b>10 ... 50</b>	<b>Excellent</b>	<b>Good</b>	<b>Excellent</b>
<b>F</b> Fluorinated rubber	<b>-20 ... +80</b>	<b>Low</b>	<b>Low</b>	<b>Low</b>
<b>E-EPDM</b>	<b>-30 ... +150</b>	<b>Good</b>	<b>Low</b>	<b>Excellent</b>

## Series 1900

### Standard round suction cup

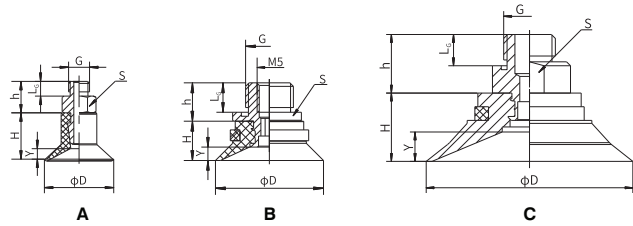

Code	Version	Drawing	D	H	G	L <sub>G</sub>	h	S	Y
19VTN.V.05.004.00	NBR	A	9	7	M5	3.5	7.5	7	2
19VTN.V.05.010.00	NBR	A	11	10.5	M5	3.5	7.5	7	2
19VTN.V.18.020.00	Silicone	B	22	8	G1/8"	6	7.8	13	2.2
19VTN.V.18.030.00	Silicone	B	32	9.5	G1/8"	6	7.8	13	4.5
19VTN.V.18.040.00	Silicone	C	42	13	G1/8"	6	12	17	5.2
19VTN.V.14.050.00	Silicone	C	53	17.5	G1/4"	9	17	24	7



Standard round suction cup, suitable for gripping and moving with vacuum objects with flat or slightly curved surfaces, allows gripping on concave surfaces.

Table of lifting forces

Code	Version	Volume cm <sup>3</sup>	Lifting force in vertical direction (N)			Lifting force in parallel direction (N)			Weight (gr.)
			-20kPa	-60kPa	-90kPa	-20kPa	-60kPa	-90kPa	
19VTN.V.05.004.00	NBR	0.03	0.198	0.885	1.275	0.198	0.78	1	2.3
19VTN.V.05.008.00	NBR	0.1	1	2.55	3.8	1	2.85	3.35	2
19VTN.V.05.010.00	NBR	0.18	1.48	4.4	6.85	1.5	4.4	4.9	2.7
19VTN.V.18.020.00	Silicone	1	5.9	12.2	16	5.9	8.8	9.8	3
19VTN.V.18.030.00	Silicone	2	13	25	33	7.8	9.8	11	4.2
19VTN.V.18.040.00	Silicone	5.5	20	37.5	60	13.8	22	27.5	11
19VTN.V.14.050.00	Silicone	12	35.5	74	95	20	37	44	26.6

Material	Colour	Hardness °Shore A	Working temperature °C
NBR	Black	55	-20 ... 110
Silicone	Red	50	-40 ... 200

### Cup-style round suction cup

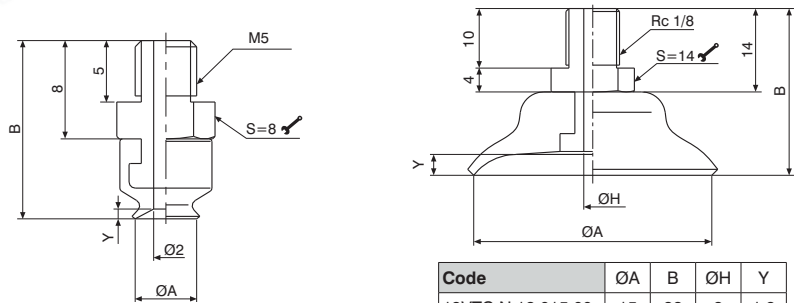

Code	ØA	B	Y
19VTC.N.05.006.00	6	14.5	0.8
19VTC.N.05.008.00	8	15	1.2
19VTC.N.05.010.00	10	15.5	1.5

Code	ØA	B	ØH	Y
19VTC.N.18.015.00	15	22	2	1.9
19VTC.N.18.020.00	20	24	3	2.3
19VTC.N.18.030.00	30	26	3	2
19VTC.N.18.040.00	40	28	3	3.5
19VTC.N.18.050.00	50	29	4	4



Typical cup-shaped suction cup, suitable for gripping and moving with vacuum objects with flat or slightly curved surfaces, allows gripping on concave surfaces.

Table of lifting forces

Code	Volume cm <sup>3</sup>	Lifting force in vertical direction (N)		Weight (gr.)
		-60kPa	-90kPa	
19VTC.N.05.006.00	0.03	0.885	1.275	2.3
19VTC.N.05.008.00	0.1	2.55	3.8	2
19VTC.N.05.010.00	0.18	4.4	6.85	2.7
19VTC.N.18.015.00	0.9	12.2	16	3
19VTC.N.18.020.00	2.5	25	33	4.2
19VTC.N.18.030.00	5	37.5	60	11
19VTC.N.18.040.00	12	74	95	26.6
19VTC.N.18.050.00	15	74	95	26.6

Material	Color	Hardness °Shore A	Working temperature °C
NBR	Black	55	-20 ... 110

Round flat suction cup

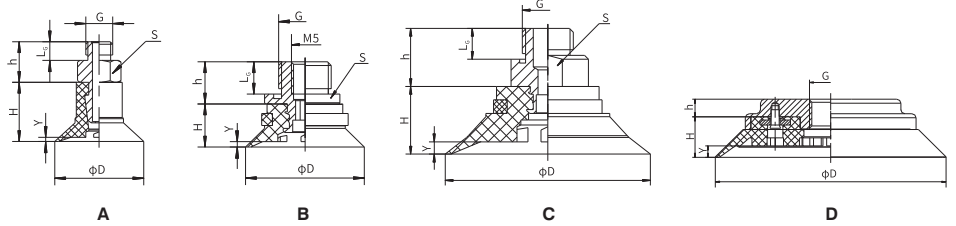

Code V=Version N=NBR / S=Silicone	Drawing	D	H	G	L <sub>G</sub>	h	S	Y
19VTP.V.05.015.00	A	16,5	11	M5	3,5	7,5	7	0,8
19VTP.V.18.020.00	B	22	8	G1/8"	6	7,8	13	1
19VTP.V.18.025.00	B	27	9	G1/8"	6	7,8	13	1
19VTP.V.18.030.00	B	32	10	G1/8"	6	7,8	13	1,2
19VTP.V.18.040.00	C	42	13	G1/8"	6	12	17	1,2
19VTP.V.14.050.00	C	53	17,5	G1/4"	9	17	24	3,2
19VTP.V.14.075.00	D	77	13	G1/4"	*	13	*	4
19VTP.V.12.110.00	D	112	20	G1/2"	*	9	*	6
19VTP.V.12.150.00	D	152	26	G1/2"	*	10	*	8



Round flat suction cup, suitable for gripping and moving with vacuum, objects with flat surfaces, offers good stability and minimal displacement. Recommended for applications with force parallel to grip plane, suitable for moving glass, wood, steel and plastic sheets. Internal reinforcements prevent thin objects from deforming and increase friction in applications with forces parallel to grip plane.

Code V=Version N=NBR / S=Silicone	Volume cm <sup>3</sup>	Lifting force in vertical direction (N)			Lifting force in parallel direction (N)			Weight (gr.)
		-20kPa	-60kPa	-90kPa	-20kPa	-60kPa	-90kPa	
		19VTP.V.18.020.00	1	6	15	18.7	5	
19VTP.V.18.025.00	1.1	9.2	19.3	24.9	7.95	8.95	10	3.6
19VTP.V.18.030.00	2	13	24.8	30.8	11	15.98	20	4.5
19VTP.V.18.040.00	4.8	20	40	50	15	25	29.5	11.5
19VTP.V.14.050.00	10	37	74	96	24	40	50	27.9
19VTP.V.14.075.00	20	80	201	272	60	110	140	121.3
19VTP.V.12.110.00	70	141	418.5	562	140	248	299.7	245.3
19VTP.V.12.150.00	160	300	845	1098	250	600	800	605

Material	Color	Hardness °Shore A	Working temperature °C
NBR	Black	55	-20 ... 110
Silicone	Red	50	-40 ... 200

Table of lifting forces

Round flat suction cup with touch valve

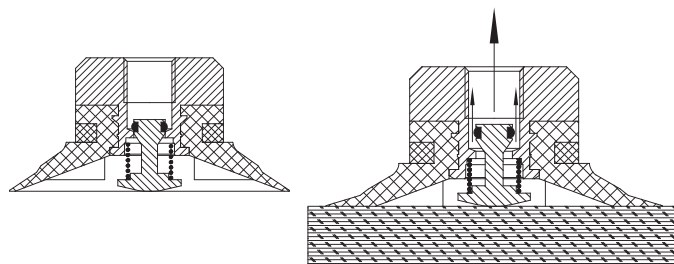
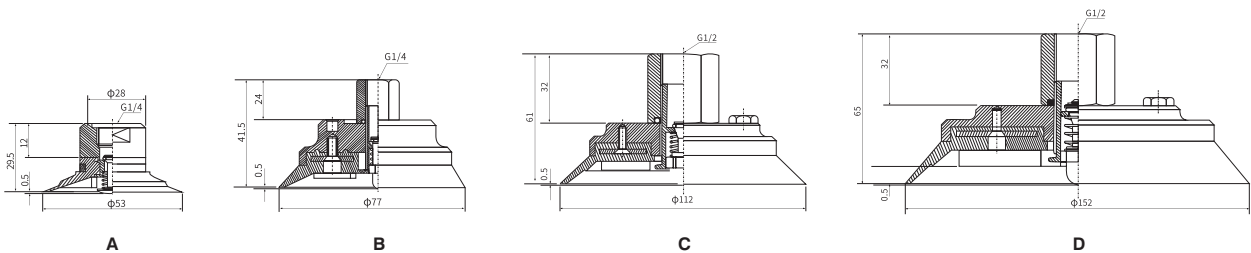

Code V=Version N=NBR / S=Silicone	Drawing
19VTP.N.27.050.00	A
19VTP.N.27.075.00	B
19VTP.N.28.110.00	C
19VTP.N.28.150.00	D
19VTP.S.27.050.00	A
19VTP.S.27.075.00	B
19VTP.S.28.110.00	C
19VTP.S.28.150.00	D



When the suction cup is not in contact with the workpiece, the touch valve closes the suction avoiding loss of flow rate.  
When the suction cup is not in contact with the workpiece, the touch valve is activated by opening the suction and ensuring normal operation of the suction cup.

Flat round bellows suction cup for plastic film

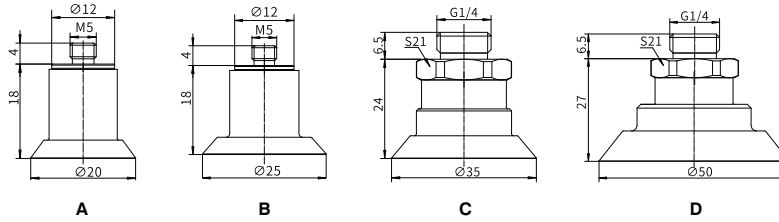

Code	Drawing
19VTF.S.05.020.00	A
19VTF.S.05.025.00	B
19VTF.S.14.035.00	C
19VTF.S.14.050.00	D



Specially designed for opening plastic bags. Suitable for handling thin and delicate objects, such as plastic films or paper. The thin and adaptable lip together with the internal plugs avoid damages to the film during the suction phase.

Table of lifting forces

Code V=Version N=NBR / S=Silicone	Volume cm <sup>3</sup>	Lifting force in vertical direction (N)		Lifting force in parallel direction (N)		Stroke (mm)	Weight (gr.)
		-60kPa	-60kPa	-60kPa	-60kPa		
19VTF.S.05.020.00	1	10	6	1,5	4,6		
19VTF.S.05.025.00	1,6	25	21	1,5	5,0		
19VTF.S.14.035.00	2,1	38	32,5	1,5	10,0		
19VTF.S.14.050.00	6	92	76	2	25,0		

Material	Color	Hardness °Shore A	Working temperature °C
Silicone	Blue	40	-40 ... 200

Round bellows suction cup

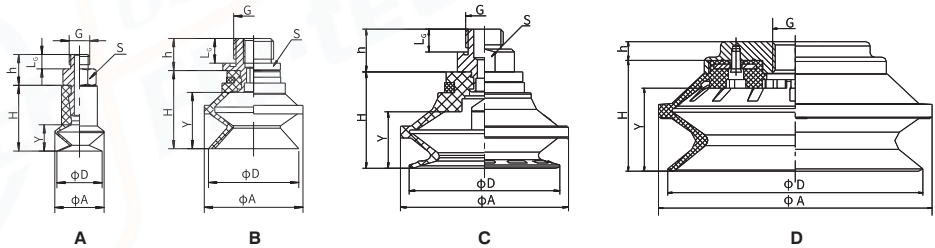

Code V=Version N=NBR / S=Silicone	Drawing	D	A	H	G	L <sub>G</sub>	h	S	Y
19VTS.V.05.005.15	A	5,8	6,2	9,2	M5	3,5	7,5	7	3,6
19VTS.V.05.010.15	A	11	12	16	M5	3,5	7,5	7	7
19VTS.V.05.015.15	A	15,5	17,5	19,5	M5	3,5	7,5	7	10
19VTS.V.18.020.15	B	22	24	19	G1/8	6	7,8	13	9
19VTS.V.18.030.15	C	34	36	26	G1/8	6	12	17	19
19VTS.V.18.040.15	C	43	46	28	G1/8	6	12	17	20
19VTS.V.14.050.15	C	53	58	35	G1/4	9	17	24	20
19VTS.V.24.075.15	D	78	83	37	G1/4	*	13	*	27
19VTS.V.26.110.15	D	115	124	54	G1/2	*	9	*	38,5
19VTS.V.26.150.15	D	155	166	71	G1/2	*	10	*	44,5



Round bellows suction cup, which, due to its shape, ensures that when in contact with the surface of the load to be lifted and in the presence of vacuum, it rapidly collapses, releasing the load of several millimetres, separately from the movements of the automation system; this rapid movement prevents the load underneath from remaining stuck to the one being lifted. For this reason, suction cups with this feature are recommended in cases where you need to pick off and move sheets of cardboard, fine sheets, wood panels, glass panes etc. and are also recommended for use on curved surfaces. This suction cup is not suitable for handling objects with lifting force parallel to the surface.

Table of lifting forces

Code V=Version N=NBR / S=Silicone	Volume cm <sup>3</sup>	Lifting force in vertical direction (N)			Weight (gr.)
		-20kPa	-60kPa	-90kPa	
19VTS.V.05.005.15	0.05	0.295	0.786	0.99	2
19VTS.V.05.010.15	0.48	1.7	3.5	5.1	2.9
19VTS.V.05.015.15	1.1	3.3	6	8.9	3.5
19VTS.V.18.020.15	2.7	5.8	10.6	15	5
19VTS.V.18.030.15	10	13	25	28	13.6
19VTS.V.18.040.15	15	22.5	42	50.2	20.2
19VTS.V.14.050.15	32	34	65	83	39.5
19VTS.V.12.075.15	110	74	166.4	226	131.3
19VTS.V.12.110.15	310	136.5	343	460.5	316.6
19VTS.V.12.150.15	650	295	686	883	733.3

Material	Color	Hardness °Shore A	Working temperature °C
NBR	Black	55	-20 ... 110
Silicone	Red	50	-40 ... 200

▶ Long bellows suction cup

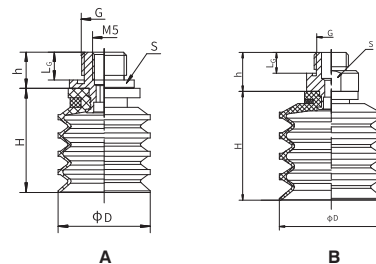

Code V=Version N=NBR / S=Silicone	Drawing	D	H	G	L <sub>G</sub>	h	S
19VTS.V.18.020.45	A	20	23	G1/8	6	7,8	13
19VTS.V.18.030.45	B	30	32	G1/8	6	12	17
19VTS.V.18.040.45	B	40	42	G1/8	6	12	17
19VTS.V.14.050.45	B	50	52	G1/4	9	17	24

Long bellows suction cup which, due to its shape, makes it possible to compensate for differences in height. Its upward movements are particularly suitable for the separation of thin products, and suitable for handling food packed in plastic bags and for fragile objects. This suction cup is not suitable for handling objects with lifting force parallel to the surface.

Table of lifting forces

Code V=Version N=NBR / S=Silicone	Volume cm <sup>3</sup>	Lifting force in vertical direction (N)		Weight (gr.)
		-20kPa	-60kPa	
19VTS.V.18.020.45	4	0.3	0.6	3.9
19VTS.V.18.030.45	13	0.6	1.55	12.4
19VTS.V.18.040.45	27	1.05	2.15	19.8
19VTS.V.14.050.45	55	1.68	4.22	38.3

Material	Color	Hardness °Shore A	Working temperature °C
NBR	Black	55	-20 ... 110
Silicone	Red	50	-40 ... 200

▶ Long bellows suction cup for bags

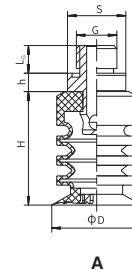

Code V=Version N=NBR / S=Silicone	Drawing	D	H	h	L <sub>G</sub>	G	S
19VTS.S.14.030.35	A	30	36,5	6	9	G1/4	19
19VTS.S.38.040.35	A	40	40	6	10	G3/8	22
19VTS.S.12.050.35	A	50	55	6	10	G1/2	28

The long bellows suction cup is especially suited for the movement of bags, thanks to its very thin lip and internal notchings, which allow it to ensure secure gripping even with heavy bags that are difficult to lift.

Table of lifting forces

Code	Volume cm <sup>3</sup>	Lifting force in vertical direction (N)	Weight (gr.)
		-60kPa	
19VTS.S.14.030.35	8.5	9	17.6
19VTS.S.38.040.35	14	15	23.6
19VTS.S.12.050.35	26	25	44.2

Material	Color	Hardness °Shore A	Working temperature °C
Silicone	Red	40	-40 ... 200

High friction round suction cup

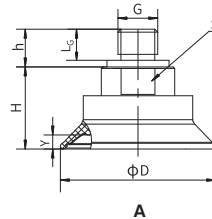

Code	Drawing	D	H	G	L <sub>g</sub>	h	S	Y
19GTN.N.14.030.00	A	32	19,5	G1/4	12	13,5	16	2,7
19GTN.N.14.040.00	A	42	22	G1/4	12	13,5	17	3,7
19GTN.N.14.050.00	A	52	28	G1/4	12	13,5	22	4,7
19GTN.N.14.060.00	A	62,5	31	G1/4	12	13,5	22	6
19GTN.N.14.080.00	A	83	34,5	G1/4	12	13,5	22	6
19GTN.N.14.100.00	A	102	36,5	G1/4	12	13,5	22	9,2

High friction round suction cup suitable for movement of pieces of various size and shape, reinforced internal structure ensures that lifted objects are not deformed and increases friction force in applications with force parallel to the grip plane. The innovative design of the support plane inside the suction cup ensures high coefficient of friction with the grip surface, in particular on very oily sheets or glass panes and very wet marble, thanks to this suction cup's drainage capability. This suction cup is most particularly recommended for applications of handling sheet metal parts in the "automotive" industry. This characteristic means that there is a secure and solid grip by the suction cup and consequently ensures accurate positioning of the load to be moved.

Table of lifting forces

Code	Volume cm <sup>3</sup>	Lifting force in vertical direction (N)	Lifting force in parallel direction (N)	Lateral force on oily surface (N)	Weight (gr.)
		-60kPa	-60kPa	-60kPa	
19GTN.N.14.030.00	1.6	45	35	33	28.3
19GTN.N.14.040.00	3.5	72	54	51	30.1
19GTN.N.14.050.00	7.5	112	90	86	55.4
19GTN.N.14.060.00	12.6	145	102	93	62.6
19GTN.N.14.080.00	35	288	212	190	81.4
19GTN.N.14.100.00	60	445	322	308	96.6

Material	Color	Hardness °Shore A	Working temperature °C
NBR	Orange	60	-20 ... 110

High friction round bellows suction cup

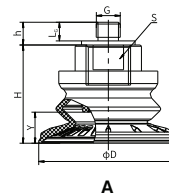

Code	Drawing	D	H	G	L <sub>g</sub>	h	S	Y
19GTS.N.14.022.15	A	22	25	G1/4	12	13,5	16	5,5
19GTS.N.14.030.15	A	32	28	G1/4	12	13,5	17	9,5
19GTS.N.14.040.15	A	42	28,5	G1/4	12	13,5	17	10
19GTS.N.14.050.15	A	52	36,2	G1/4	12	13,5	22	11,5
19GTS.N.14.060.15	A	62,5	41	G1/4	12	13,5	22	14,5
19GTS.N.14.080.15	A	82	49,5	G1/4	12	13,5	22	22,5
19GTS.N.14.100.15	A	103	55	G1/4	12	13,5	22	25

High friction round bellows suction cup suitable for movement of pieces of various size and shape and where level compensation is necessary, such as when withdrawing from loaders. Especially recommended for applications with force parallel to the grip plane. The innovative design of the support plane inside the suction cup ensures high coefficient of friction with the grip surface, in particular on very oily sheets or glass panes and very wet marble, thanks to this suction cup's drainage capability. This feature enables a secure and solid grip by the suction cup and consequently ensures accurate positioning of the load to be moved.

Table of lifting forces

Code	Volume cm <sup>3</sup>	Lifting force in vertical direction (N)	Lifting force in parallel direction (N)	Lateral force on oily surface (N)	Weight (gr.)
		-60kPa	-60kPa	-60kPa	
19GTS.N.14.022.15	1.5	23	20	6.5	25.2
19GTS.N.14.030.15	6.3	35	28	12	29.5
19GTS.N.14.040.15	7.2	62	37	34	30.9
19GTS.N.14.050.15	11.2	85	58	55	56.3
19GTS.N.14.060.15	22.5	141	88	83	64.4
19GTS.N.14.080.15	57	236	141	136	86.4
19GTS.N.14.100.15	92	371	228	221	116.6

Material	Color	Hardness °Shore A	Working temperature °C
NBR	Orange	60	-20 ... 110

► High friction oval suction cup

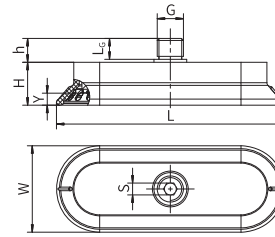

A

Code	Drawing	L	W	H	G	L <sub>G</sub>	h	S	Y
19GEN.N.14.JxD.00	A	50	16	19,5	G1/4	12	13,5	5	3
19GEN.N.14.AxH.00	A	84	24	15,5	G1/4	12	13,5	5	5
19GEN.N.14.BxL.00	A	93	33	16	G1/4	12	13,5	5	5
19GEN.N.14.CxN.00	A	113	43	21,5	G1/4	12	13,5	5	6
19GEN.N.14.FxO.00	A	123	65	18	G1/4	12	13,5	5	6



METAL SHEET

SLIP RESISTANCE

OILY SURFACES

High friction oval suction cup suitable for movement of elongated thin pieces; the reinforced internal structure ensures that lifted objects are not deformed and increases friction force in applications with force parallel to the grip plane. The innovative design of the support plane inside the suction cup ensures high coefficient of friction with the grip surface, in particular on very oily sheets or glass panes and very wet marble, thanks to this suction cup's drainage capability. This suction cup is most particularly recommended for applications of handling sheet metal parts in the "automotive" industry. This feature enables a secure and solid grip by the suction cup and consequently ensures accurate positioning of the load to be moved.

Code	Volume cm <sup>3</sup>	Lifting force in vertical direction (N)	Lifting force in parallel direction (N)	Lateral force on oily surface (N)	Weight (gr.)
		-60kPa	-60kPa	-60kPa	
19GEN.N.14.JxD.00	2	33	24	12	17
19GEN.N.14.AxH.00	5	78	38	35	23
19GEN.N.14.BxL.00	10	125	77	60	24
19GEN.N.14.CxN.00	25	200	188	118	47
19GEN.N.14.FxO.00	35	312	254	170	70

Material	Color	Hardness °Shore A	Working temperature °C
NBR	Orange	60	-20 ... 110

Table of lifting forces

► Oval high-friction bellows suction cup

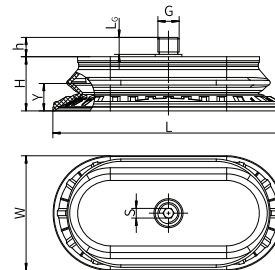

A

Code	Drawing	L	W	H	G	L <sub>G</sub>	h	S	Y
19GES.N.14.BxF.15	A	62	31	20	G1/4	12	13,5	5	6
19GES.N.14.CxH.15	A	82	41	22,7	G1/4	12	13,5	5	8,8
19GES.N.14.ExN.15	A	112	57	29	G1/4	12	13,5	5	12,5
19GES.N.14.GxR.15	A	143	70,5	33	G1/4	12	13,5	5	17



METAL SHEET

SLIP RESISTANCE

OILY SURFACES

High friction oval bellows suction cup suitable for movement of elongated and thin pieces and where level compensation is necessary, such as in the withdrawal of loaders. Especially recommended for applications with force parallel to the grip plane. The innovative design of the support plane inside the suction cup ensures a high coefficient of friction with the grip surface, in particular on very oily sheets or glass panes and very wet marble, thanks to this suction cup's drainage capability. This feature enables a secure and solid grip by the suction cup and consequently ensures accurate positioning of the load to be moved.

Code	Volume cm <sup>3</sup>	Lifting force in vertical direction (N)	Lifting force in parallel direction (N)	Lateral force on oily surface (N)	Weight (gr.)
		-60kPa	-60kPa	-60kPa	
19GES.N.14.BxF.15	8.7	53	60	50	41.9
19GES.N.14.CxH.15	22	110	118	101	51.5
19GES.N.14.ExN.15	57	197	200	183	102.1
19GES.N.14.GxR.15	108	275	295	267	138.9

  

Material	Color	Hardness °Shore A	Working temperature °C
NBR	Orange	60	-20 ... 110

Table of lifting forces



Standard round suction cup made of polyurethane

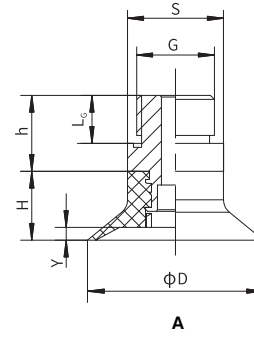

Code	Drawing	D	H	G	h	L <sub>G</sub>	Y	S
19VTN.P.18.030.00	A	31	10,5	G1/8	7,8	6	2	13
19VTN.P.18.040.00	A	41	14	G1/8	12	6	2,5	17

Standard round suction cup made of polyurethane, suitable for gripping and moving with vacuum, objects with flat or slightly curved surfaces, allows gripping on concave surfaces. The big advantage of this suction cup, is that the material it's made of, polyurethane, lasts longer than other materials, has optimum wear resistance, good flexibility and Polyurethane suction cups are mark resistant.

Table of lifting forces

Code	Volume cm <sup>3</sup>	Lifting force in vertical direction (N)			Lifting force in parallel direction (N)			Weight (gr.)
		-20kPa	-60kPa	-90kPa	-20kPa	-60kPa	-90kPa	
19VTN.P.18.030.00	2	13	23	33	7.8	9.8	11	5
19VTN.P.18.040.00	5.5	20	40	60	13.8	22	27.5	11.8

Material	Color	Hardness °Shore A	Working temperature °C
PU	Yellow	40	10 ... 50

Round bellows suction cup made of polyurethane

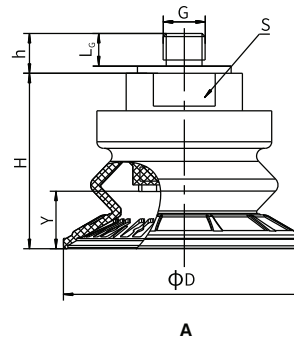

Code	Drawing	D	H	G	L <sub>G</sub>	h	S	Y
19VTS.P.14.030.15	A	32	28	G1/4	12	13,5	17	7
19VTS.P.14.040.15	A	42	29	G1/4	12	13,5	17	9
19VTS.P.14.050.15	A	51,5	37	G1/4	12	13,5	22	12,5
19VTS.P.14.060.15	A	64	41,5	G1/4	12	13,5	22	15
19VTS.P.14.080.15	A	84	49,5	G1/4	12	13,5	22	23
19VTS.P.14.100.15	A	103	55	G1/4	12	13,5	22	22

Round bellows suction cup made of polyurethane, suitable for moving pieces of various sizes and shapes and where level compensation is necessary, such as when withdrawing from loaders. The big advantage of this suction cup, is that the material it's made of, polyurethane, lasts longer than other materials, has optimum wear resistance, good flexibility and optimum tensile strength. Suitable for moving--with vacuum--steel sheets, glass sheets, cardboard boxes and wood panels.

Table of lifting forces

Code	Volume cm <sup>3</sup>	Lifting force in vertical direction (N)			Lifting force in parallel direction (N)			Weight (gr.)
		-20kPa	-60kPa	-90kPa	-20kPa	-60kPa	-90kPa	
19VTS.P.14.030.15	6	11	60.2	91	8.4	30.5	76	30
19VTS.P.14.040.15	7.2	17.5	93	119.8	11.3	63.8	110.8	30.6
19VTS.P.14.050.15	11	25	128.5	157.8	20.5	94	144	58.5
19VTS.P.14.060.15	22	87.3	156.2	189.2	67	125.6	165.8	67.9
19VTS.P.14.080.15	59.5	118.6	210.5	252.6	89	167.8	221.2	89.9
19VTS.P.14.100.15	103.5	149	269.5	310.4	111.8	209.8	276.5	135.3

Material	Color	Hardness °Shore A	Working temperature °C
PU	Blu	70	10 ... 50

▶ Round bellows suction cup made of polyurethane

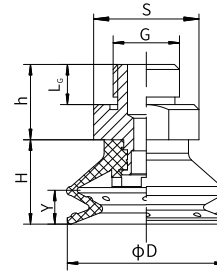

A

Code V=Version N=NBR / S=Silicone	Drawing	D	H	G	h	L <sub>G</sub>	Y	S
19VTS.P.18.030.15	A	31,5	16,8	G1/8	12	6	6,6	17
19VTS.P.18.040.15	A	42	22,4	G1/8	12	6	8,8	17
19VTS.P.38.050.15	A	52,5	29,3	G3/8	13	10	12,3	24

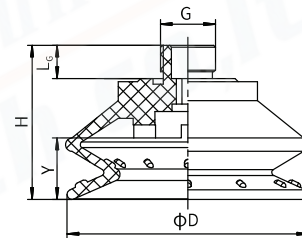

B

Code V=Version N=NBR / S=Silicone	Drawing	D	H	G	L <sub>G</sub>	Y	S
19VTS.P.38.070.15	B	73	46,5	G3/8	10	16,5	*



Round bellows suction cup made of polyurethane, suited for movement of pieces of various size and shape and where level compensation is necessary, such as when withdrawing from loaders. The big advantage of this suction cup, is that the material it's made of, polyurethane, lasts longer than other materials, has optimum wear resistance, good flexibility and optimum tensile strength. Polyurethane suction cups are mark resistant.

Table of lifting forces

Code	Volume cm <sup>3</sup>	Lifting force in vertical direction (N)			Weight (gr.)
		-20kPa	-60kPa	-90kPa	
19VTS.P.18.030.15	10	13	30	37	10.3
19VTS.P.18.040.15	15	22.5	60	75	17.3
19VTS.P.38.050.15	32	34	86	100	33.4
19VTS.P.38.070.15	108	74	165	225	60.6

Material	Color	Hardness °Shore A	Working temperature °C
PU	Yellow	40	10 ... 50

SUCTION CUPS

Round bellows suction cup made of polyurethane

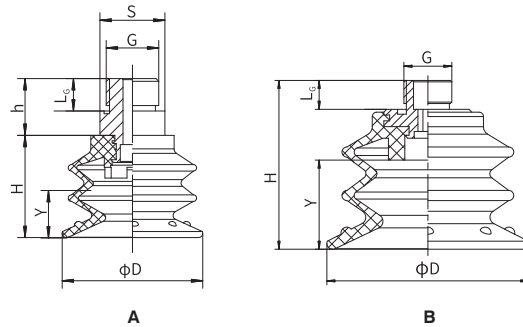

SUCTION CUPS



Code	Drawing	D	H	G	h	L <sub>c</sub>	Y	S
19VTS.P.18.020.25	A	21	14,8	G1/8	7,8	6	4,5	13
19VTS.P.18.030.25	A	30	21,3	G1/8	7,8	6	8	13
19VTS.P.18.040.25	A	40	28,4	G1/8	12	6	10,6	17
19VTS.P.38.050.25	A	50	35,5	G3/8	18	10	13,4	24
19VTS.P.38.070.25	B	70	58,5	G3/8	*	10	18,6	*

Round bellows suction cup made of polyurethane, suitable for movement of pieces of various size and shape and where level compensation is necessary, such as when withdrawing from loaders. The big advantage of this suction cup, is that the material it's made of, polyurethane, lasts longer than other materials, has optimum wear resistance, good flexibility and optimum tensile strength. Suitable for moving porous objects or ones with an irregular surface, such as cardboard. Polyurethane suction cups are mark resistant.

Table of lifting forces

Code	Volume cm <sup>3</sup>	Lifting force in vertical direction (N)			Weight (gr.)
		-20kPa	-60kPa	-90kPa	
19VTS.P.18.020.25	1.18	4.5	7	10	4.2
19VTS.P.18.030.25	9	10	19	25	6.9
19VTS.P.14.040.25	15	15	32	50	18.2
19VTS.P.38.050.25	30	35	58	79	32.6
19VTS.P.38.070.25	75	72	125	150	60.5

Material	Color	Hardness °Shore A	Working temperature °C
PU	Green	55	10 ... 50

**Foam rubber round suction cup**

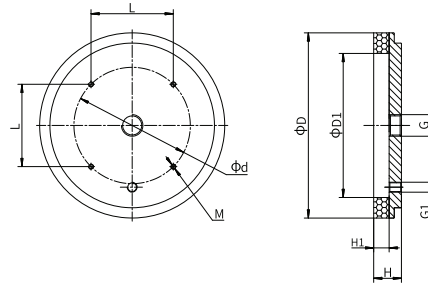

A

Code	Drawing	D	D1	H	H1	G1	L	M	d	G
19VTN.G.14.040.00	A	40	20	25	15	-	-	-	-	G1/4
19VTN.G.14.064.00	A	64	40	25	15	-	-	-	40	G1/4
19VTN.G.38.092.00	A	92	64	26	15	-	-	4-M5	70	G3/8
19VTN.G.12.127.00	A	127	92	30	15	G1/8	70	4-M5	-	G1/2



Foam rubber round suction cup is made from a special mixture called "NR", which has a density that allows for gripping even on very rough and irregular surfaces, and allows its elasticity to be maintained even after several working cycles. Especially suited for moving loads with coarse or very rough surfaces such as: sawn, bush-hammered or flamed marble, textured, non-slip or ribbed/corrugated sheets, brick, items made of rough concrete, garden walkway tiles, etc., and in general in all cases where traditional suction cups cannot be used. Recommended for handling loads with lifting force parallel to the surface and for the movement of loads with oiled surfaces.

Table of lifting forces

Code	Lifting force in vertical direction (N)		Weight (gr.)
	-60kPa		
19VTN.G.14.040.00	7.8		33.4
19VTN.G.14.064.00	35		82.4
19VTN.G.38.092.00	85		197.8
19VTN.G.12.127.00	175		489.3

Material	Color	Hardness °Shore A	Working temperature °C
Foam rubber "NR"	Orange	30	-20 ... 80

**Foam rubber rectangular suction cup**

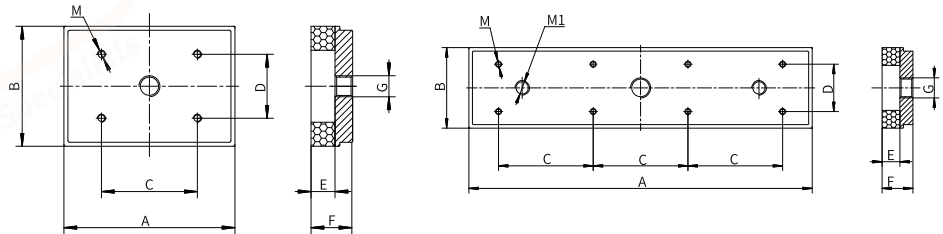

A

B

Code	Drawing	A	B	C	D	E	F	G	M	M1
19VRN.14.FxR.00	A	135	60	80	40	15	26	G1/4	4-M5	-
19VRN.14.HxN.00	A	107	75	60	40	15	26	G1/4	4-M5	-
19VRN.12.RxS.00	B	290	140	80	100	15	26	G1/2	8-M5	2-M12

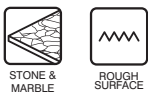

Foam rubber rectangular suction cup is made from a special mixture called "NR", which has a density that allows for gripping even on very rough and irregular surfaces, and allows its elasticity to be maintained even after several working cycles. Especially suited for movement of loads with coarse or very rough surfaces such as: sawn, bush-hammered or flamed marble, textured, non-slip or ribbed/corrugated sheets, brick, items made of rough concrete, garden walkway tiles, etc. and in general in all cases where traditional suction cups cannot be used. Not recommended for handling loads with lifting force parallel to the surface or for the movement of loads with oiled surfaces.

Table of lifting forces

Code	Lifting force in vertical direction (N)		Weight (gr.)
	-60kPa		
19VRN.14.FxR.00	80		231,7
19VRN.14.HxN.00	90		236,7
19VRN.12.RxS.00	706		1175,1

Material	Color	Hardness °Shore A	Working temperature °C
Foam rubber "NR"	Orange	30	-20 ... 80