



▶ 180° angular gripper rack & pinion style



Ordering code

6303.Ø.D

F = Fingers, end fixing
L = Fingers, side fixing

20
25
32
40
50

Construction characteristics

Body	anodised aluminium
Piston	aluminium
Fingers	steel
End cap	anodised aluminium

Operational characteristics

Function	double acting
Fluid	Filtered air. No lubrication needed, if applied it shall be continuous.
Working pressure	1.5 - 7 bar
Working temperature	-5°C - +70°C
Opening total stroke	-5° - 180°
Maximum operating frequency	from Ø20 to Ø25, 60 cycles/minute from Ø32 to Ø50, 30 cycles/minute

Overall dimensions

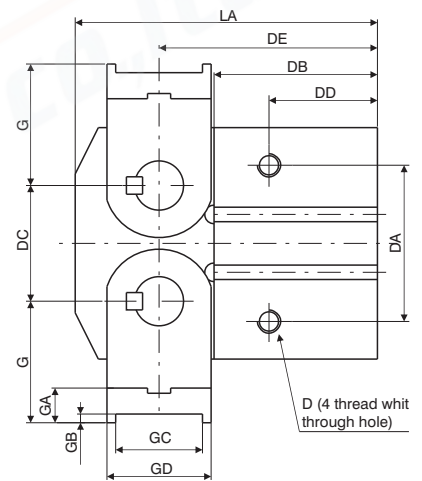
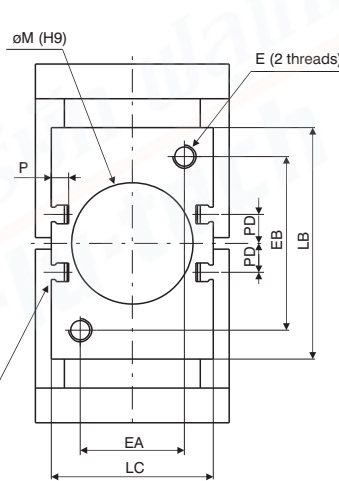
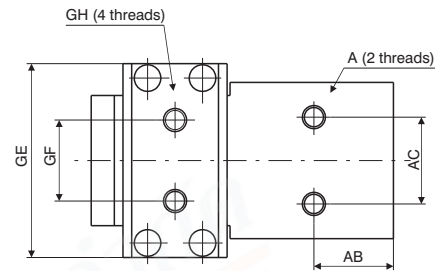
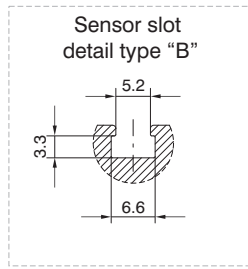

Bore		Ø20	Ø25	Ø32	Ø40	Ø50
A		M5	M6	M6	M8	M10
	Useful depth	7	10	10	15	20
AB		17	20	21	27,5	36
AC		20	24	24	30	40
D		M5	M6	M6	M8	M10
	Useful depth	10	12	12	16	20
DA		27	34	42	54	70
DB		35	40	47	56,5	69
DC		18	24	30	40	56
DD		23	27	29	37,5	48
DE		45	51	61,5	75,5	96
E		M5	M6	M6	M8	M10
	Useful depth	10	12	12	15	20
EA		26	30	30	36	40
EB		26	30	45	60	80
F		M5	M5	G1/8	G1/8	G1/4
FA		12	16	20	20	30
FB		9	10	13	14	16
FC		20	23	25	33,5	44
G		23	27	32	42	58
GA		7	8	9	12	17
GB		2	2	2	3	4
GC		12	17	23	30	44
GD		16	21	27	36	52
GE		41	45	51	67	85
GF		18	20	20	28	38
GH		M4	M5	M6	M8	M10
H		5	6	7	9	13
HA		10	12	14	21	24
HB		5	6	7	10	13
HC		28	30	34	44	58
HD		14	16	18	24	30
LA		60	69	83,5	104,5	136
LB		36	45	58	80	112
LC		36	40	45	56	66
ØM ^{H9}		21	26	34	42	52
	Useful depth	3	3	4	4	5
P		6	5,5	5,5	6	6
PD		4	4,5	11	10	13
Weight (g)		300	500	900	2100	5000

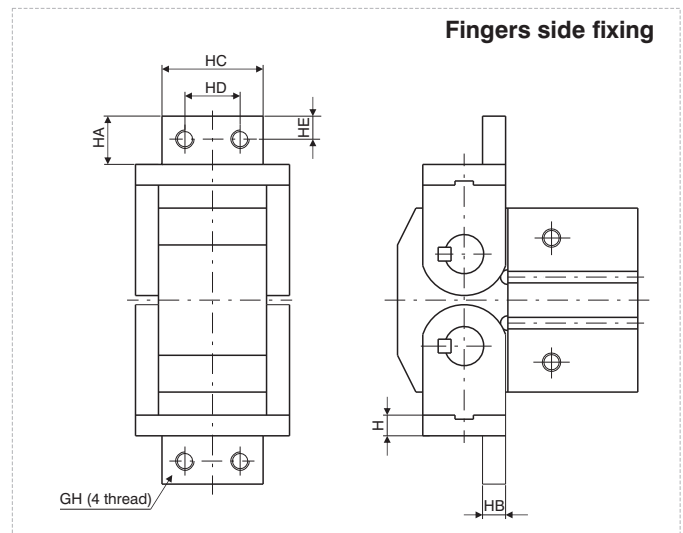
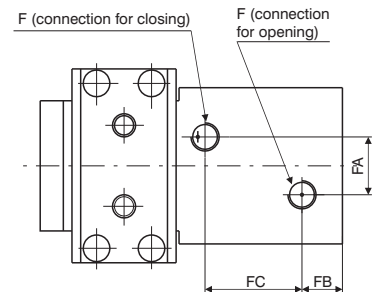



Operating criteria

Gripping force

NOTE:

Bore selection should be made considering a holding force 10 to 20 times the component weight.
 In case of acceleration/deceleration a further margin of safety should be considered.

Bore	Ø20	Ø25	Ø32	Ø40	Ø50
(Nm)	0,3	0,7	1,6	3,7	8,3

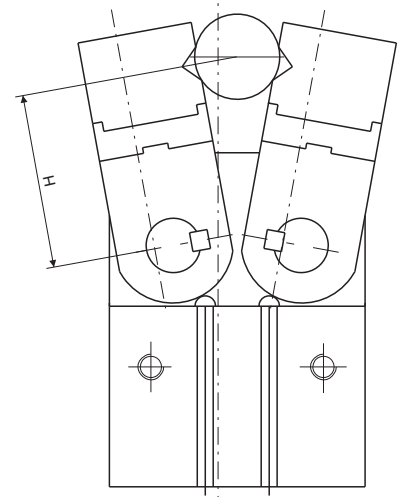
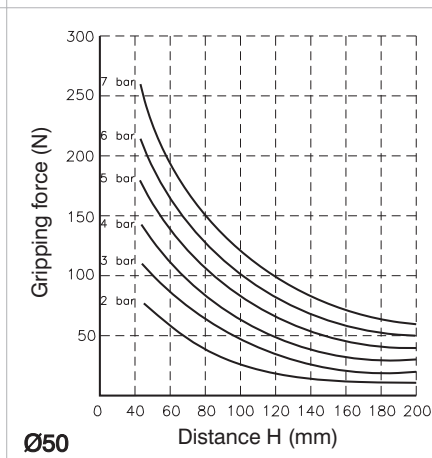
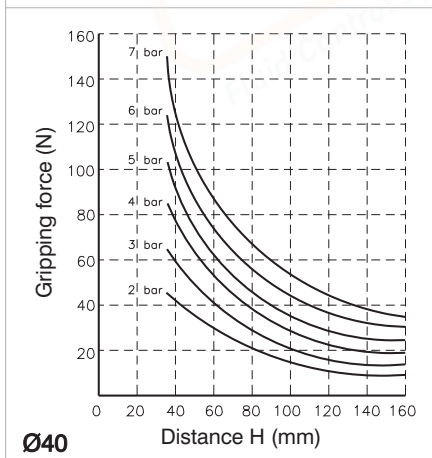
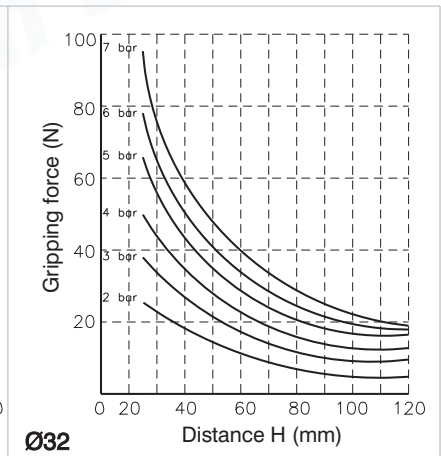
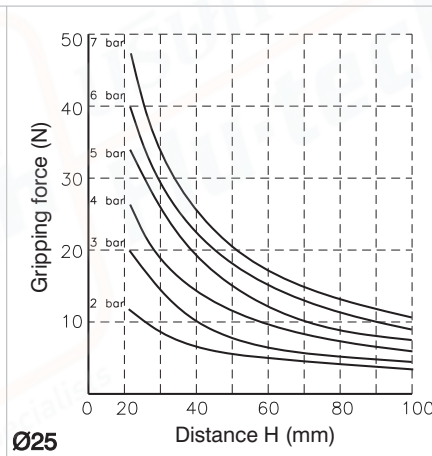
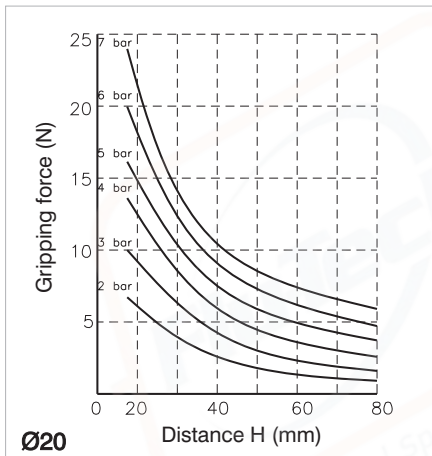

PNEUMATIC ACTUATION

