



Series 1303-1304-1305-1306-1307-1308

General

They conform to CNOMO standards, fully complying with CETOP and ISO standards, with mounted fixing devices 32 to 100.

Construction characteristic

End caps	solid aluminium bar up to Ø100, alloy aluminium from Ø125 to Ø200
Rod	C43 chromed steel, by thickness or stainless steel
Barrel	oxidised aluminium
Tie rods	steel with rolled threads
Cushion bearings	aluminium
Rod-guide bushing	brass (Ø32, 40, 50) in aluminium with self-lubricating bearings in sinterized bronze for the remaining BOREs
Piston	aluminium lathed from bar
Seals	Standard: NBR Oil resistant rubber, PUR Piston rod seals (FPM seals available upon request)

Operational characteristics

Fluid	filtered and lubricated air - hydraulic oil (with special bushing)
Pressure	max. 12 bar (air) - 20 bar (oil)
Operating temperature	-5 °C - +70 °C with 1303-1308 standard seals -5 °C - +80 °C with FPM seals for 1306-1308 series (magnetic piston) -5 °C - +150 °C with FPM seals for 1303-1305 series (non magnetic piston)
Cushioning length	Ø 32 - 40 - 50 - 63 - 80 - 100 - 125 - 160 - 200 mm 20 - 20 - 22 - 24 - 24 - 25 - 27 - 35 - 35

Please follow the suggestions below to ensure a long life for these cylinders:

- use clean and lubricated air
- correct alignment during assembly with regard to the applied load so as to avoid radial components or bending the rod.
- avoid high speeds together with long strokes and heavy loads: this would produce kinetic energy which the cylinder cannot absorb, especially if used as a limit stop (in this case use mechanical stop device)
- evaluate the environmental characteristics of cylinder used (high temperature, hard atmosphere, dust, humidity etc.)

Please note: air must be dried for applications with lower temperature.

Use hydraulic oils H class (ISO VG32) for correct continued lubrication.
Our Technical Department will be glad to help.

Standard strokes

Double acting version

From 0 to 150 every 25 mm; from 150 to 500 every 50 mm; from 500 to 1000 every 100 mm (for all bores)
On request are available strokes up to 2800 mm

Single acting version

up to stroke 50 mm

Minimum and maximum springs load for single acting version

Bore	Ø32	Ø40 - Ø50	Ø63	Ø80 - Ø100
Min. load (N)	20	25	50	100
Max. load (N)	55	80	115	200

Basic version

Ordering code
Non magnetic piston
1303.Ø.stroke.01A (CNOMO)
1304.Ø.stroke.01A (CETOP)
1305.Ø.stroke.01A (ISO)
Magnetic piston
1306.Ø.stroke.01A (CNOMO)
1307.Ø.stroke.01A (CETOP)
1308.Ø.stroke.01A (ISO)

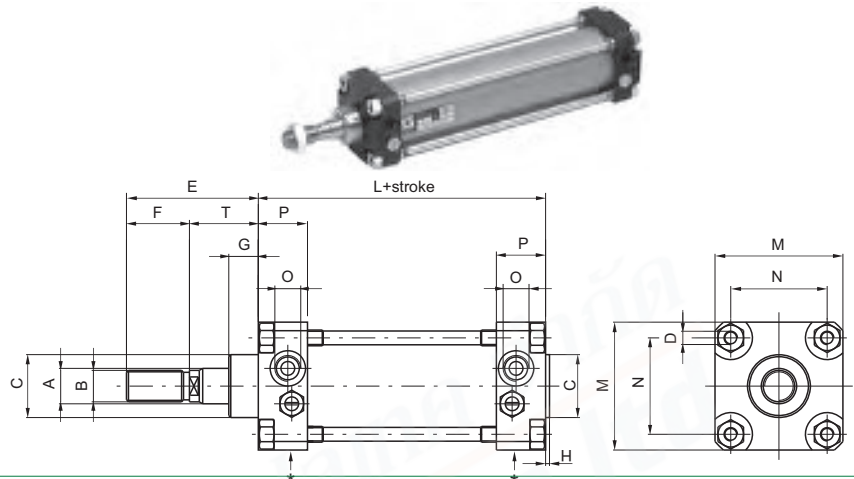

Through rod cylinder version

Ordering code
Non magnetic piston
1303.Ø.stroke.02A (CNOMO)
1304.Ø.stroke.02A (CETOP)
1305.Ø.stroke.02A (ISO)
Magnetic piston
1306.Ø.stroke.02A (CNOMO)
1307.Ø.stroke.02A (CETOP)
1308.Ø.stroke.02A (ISO)

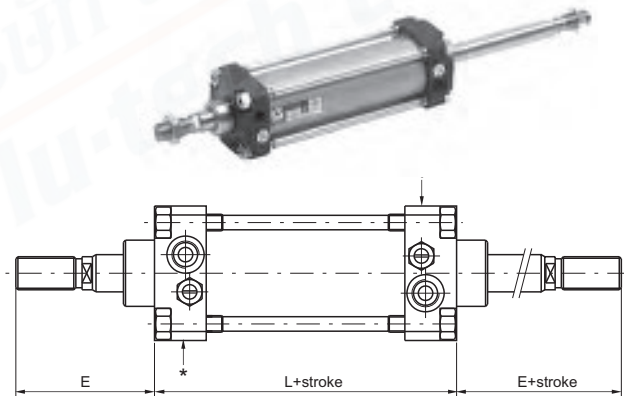

Tandem push with a common rod

Ordering code
Non magnetic piston
1303.Ø.stroke.H (CNOMO)
1304.Ø.stroke.H (CETOP)
1305.Ø.stroke.H (ISO)
Magnetic piston
1306.Ø.stroke.H (CNOMO)
1307.Ø.stroke.H (CETOP)
1308.Ø.stroke.H (ISO)

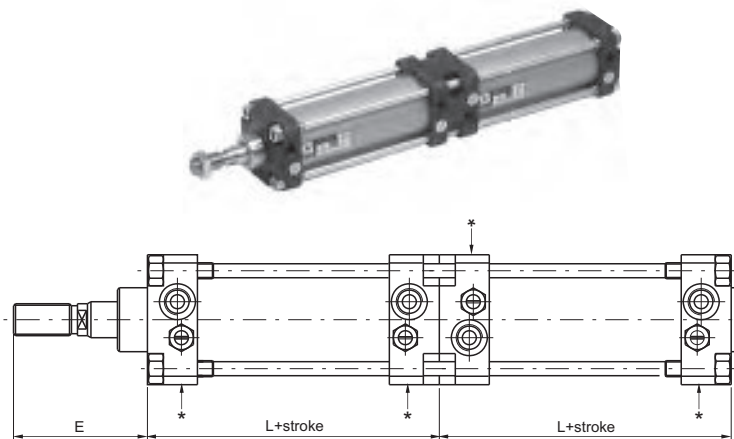

Tandem push with independent rods

Ordering code
Non magnetic piston
1303.Ø.stroke.stroke1.N (CNOMO)
1304.Ø.stroke.stroke1.N (CETOP)
1305.Ø.stroke.stroke1.N (ISO)
Magnetic piston
1306.Ø.stroke.stroke1.N (CNOMO)
1307.Ø.stroke.stroke1.N (CETOP)
1308.Ø.stroke.stroke1.N (ISO)

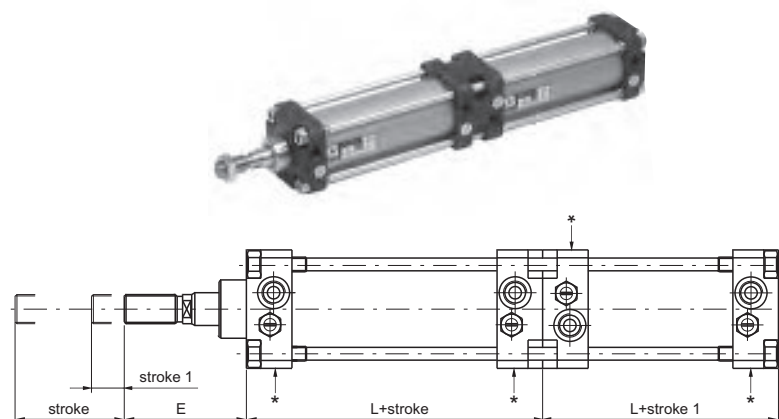

Opposed tandem with common rods

Ordering code
Non magnetic piston
1303.Ø.stroke.stroke1.R (CNOMO)
1304.Ø.stroke.stroke1.R (CETOP)
1305.Ø.stroke.stroke1.R (ISO)
Magnetic piston
1306.Ø.stroke.stroke1.R (CNOMO)
1307.Ø.stroke.stroke1.R (CETOP)
1308.Ø.stroke.stroke1.R (ISO)

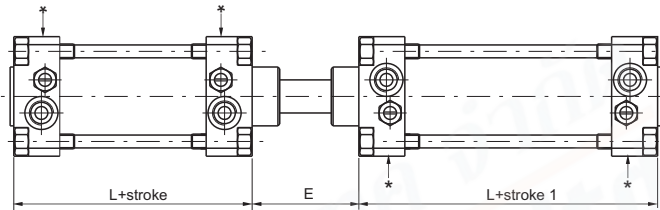

Tandem with opposed rods

Ordering code
Non magnetic piston
1303.Ø.stroke.stroke1.U (CNOMO)
1304.Ø.stroke.stroke1.U (CETOP)
1305.Ø.stroke.stroke1.U (ISO)
Magnetic piston
1306.Ø.stroke.stroke1.U (CNOMO)
1307.Ø.stroke.stroke1.U (CETOP)
1308.Ø.stroke.stroke1.U (ISO)

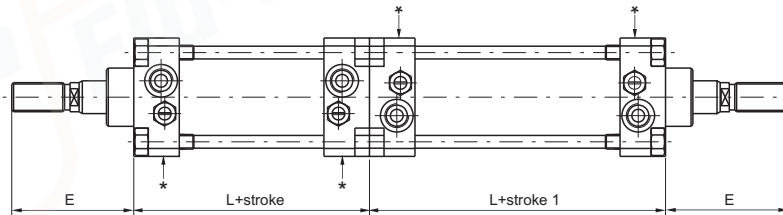

Variants

Add "X" to the cylinder code to order cylinders with STAINLESS STEEL rods. Example: **1303.32.250.01AX**.
 Add "V" to the cylinder code to order cylinders with FPM seals. Example: **1303.32.250.01AV**.
 Add "MA" to the cylinder code to order cylinders single acting front spring, with strokes not superior to 50. Example: **1303.32.50.01AMA**.
 Add "MP" to the cylinder code to order cylinders single acting rear spring, with strokes not superior to 50. Example: **1303.50.25.01AMP**.
Note: Cushion adjustment (for Ø 32, Ø 40, Ø 125, Ø 160 and Ø 200) is on the side indicated by * (see drawings).

Table of dimensions

Bore	32	40	50	63	80	100	125	160	200
A (f7)	12	18	18	22	22	30	30	40	40
B - CNOMO (6g)	M10x1,5	M16x1,5	M16x1,5	M20x1,5	M20x1,5	M27x2	M27x2	M36x2	M36x2
B - CETOP (6g)	M10x1,25	M12x1,25	M16x1,5	M16x1,5	M20x1,5	M20x1,5	M24x2	M36x2	M36x2
B - ISO (6g)	M10x1,25	M12x1,25	M16x1,5	M16x1,5	M20x1,5	M20x1,5	M27x2	M36x2	M36x2
C (d11)	25	32	32	45	45	55	55	65	65
H	2,5	2	2	2	2	2	3	3	3
D	M6	M6	M8	M8	M10	M10	M12	M16	M16
E - CNOMO	45	70	70	85	85	110	110	135	135
E - CETOP	44	52	67	67	82	87	109	152	162
E - ISO	46	52	67	67	82	87	115	152	162
F - CNOMO	20	36	36	46	46	63	63	85	85
F - CETOP	20	24	32	32	40	40	48	72	72
F - ISO	22	24	32	32	40	40	54	72	72
G	15	15	15	20	20	20	20	25	25
M	45	52	65	75	95	115	140	180	220
N	33	40	49	59	75	90	110	140	175
O	G 1/8"	G 1/4"	G 1/4"	G 3/8"	G 3/8"	G 1/2"	G 1/2"	G 3/4"	G 3/4"
P	16	23	25	31	31	35	36	45	45
T - CNOMO	25	34	34	39	39	47	47	50	50
T - CETOP-ISO	24	28	35	35	42	47	61	80	90
L - CNOMO (±1)	80	110	110	125	125	145	145	180	180
L - CETOP-ISO (±1)	98	110	110	125	136	145	168	180	190

STROKE TOLERANCE: + 2 mm.

WEIGHT IN g OF THE CYLINDERS WITH VARIOUS BARRELS (BASIC VERSION)

Bore		32	40	50	63	80	100	125	160	200
Aluminium	stroke 0	580	1010	1350	2110	3350	5400	7450	13300	18300
	every 10 mm	24	38	47	63	75	117	130	235	250

FOR CYLINDERS IN TANDEM THE WEIGHT IS APPROXIMATELY DOUBLE

► **Sensor brackets codes - 1500._, RS._, HS._**

Ordering code	1306.A				1306.B			1306.C	
	Ø32	Ø40	Ø50	Ø63	Ø80	Ø100	Ø125	Ø160	Ø200
Bore	Ø32	Ø40	Ø50	Ø63	Ø80	Ø100	Ø125	Ø160	Ø200
L	59	65	76	87	103	121	144	179	215

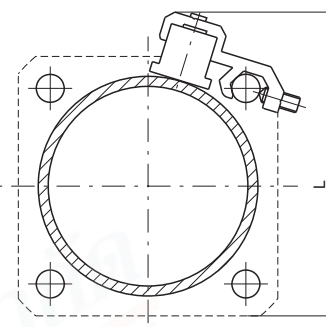

Sensor for microbore cylinders

For technical characteristics and ordering codes see Chapter 6 (magnetic sensors)

This accessory allows valves or solenoid valves to mount on the side of the cylinder. Support should be anchored to the tie rods and on it either a threaded distributor can be mounted or a base upon which an ISO distributor can be mounted. Once installed the connections must be done with fittings and pipes. All of the threaded holes on the support plate are dedicated to different valves series as per attached drawing.

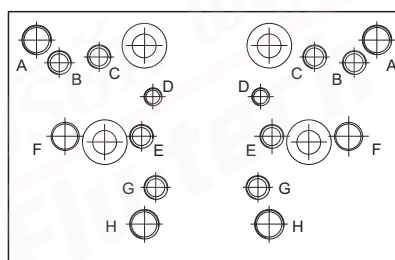

Fixing holes for valves series:

- A = 414/2
- B = 824
- C = 828, T488, 488, 484
- D = 2400
- E = 2600
- F = Bases for ISO distributors
- G = 858/2
- H = T424

3

► **Support**

Ordering code
1306.15 (Ø32 ... Ø100)

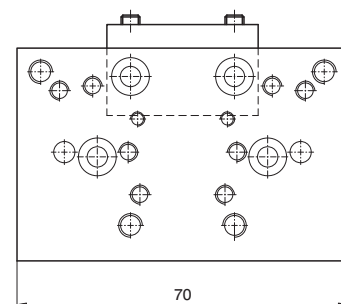

PNEUMATIC ACTUATION

► **Bases for ISO solenoid valves**

Ordering code
1320.21 bases for ISO 1 solenoid valves
1320.22 bases for ISO 2 solenoid valves

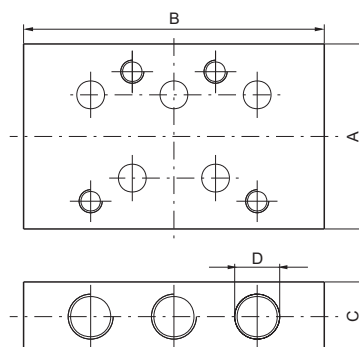

	Dimensions			
	A	B	C	D
bases for ISO 1 solenoid valves	40	75	15	G 1/8"
bases for ISO 2 solenoid valves	50	95	20	G 1/4"

Front and rear flanges

Ordering code

1303.Ø.03F
(CNOMO)
1304.Ø.03F
(CETOP - ISO)

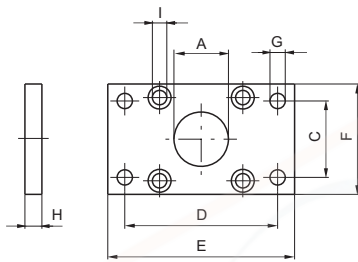
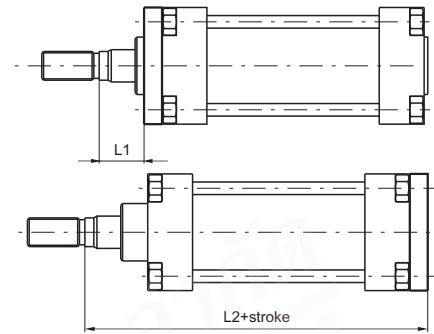

Plate which allows anchorage of the cylinder at a right angle to the plane. It is made of zinc-plated extruded steel.

Bore	32	40	50	63	80	100	125	160	200
A (H11)	25	32	32	45	45	55	55	65	65
C - CNOMO (JS 14)	33	40	49	59	75	90	110	140	175
C - CETOP ISO (JS 14)	32	36	45	50	63	75	90	115	135
D - CNOMO (JS 14)	68	78	94	104	130	150	180	228	268
D - CETOP - ISO (JS 14)	64	72	90	100	126	150	180	230	270
E	80	90	110	120	150	170	205	260	300
F	45	52	65	75	95	115	140	180	220
G - CNOMO (H13)	9	9	11	11	14	14	18	22	22
G - CETOP - ISO (H13)	7	9	9	9	12	14	16	18	22
H (JS 14)	8	8	10	10	12	12	16	20	20
I	6,5	6,5	9	9	10,5	10,5	13,5	16,5	16,5
L1 - CNOMO	17	26	24	29	27	35	31	30	30
L1 - CETOP - ISO	16	20	25	25	30	35	45	60	70
L2 - CNOMO	113	152	154	174	176	204	208	250	250
L2 - CETOP - ISO	130	145	155	170	190	205	245	280	300
Weight g	165	200	540	1060	1460	1510	3100	6400	9500

Standard feet

Ordering code

1303.Ø.05F
(CNOMO)
(1 piece)
1304.Ø.05F
(CETOP - ISO)
(1 piece)

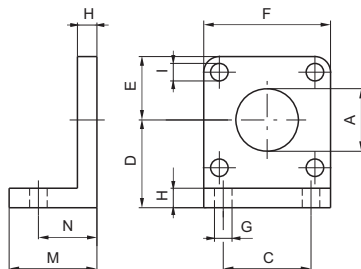
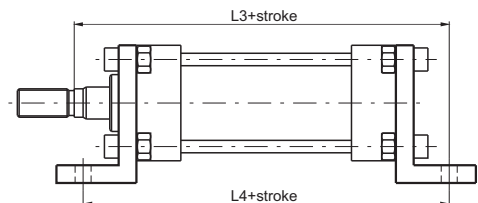

Elements used to anchor the cylinder parallel to the mounting plane. They are made of cast aluminium, painted black.

Bore	32	40	50	63	80	100	125	160	200
A (H11)	25	32	32	45	45	55	55	65	65
C - CNOMO (JS 14)	28	36	45	55	70	90	100	130	170
C - CETOP ISO (JS 14)	32	36	45	50	63	75	90	115	135
D - CNOMO (JS 15)	32	36	45	50	63	73	91	115	135
D - CETOP - ISO (JS 15)	32	36	45	50	63	71	90	115	135
E	22	26	32	37	47	57	70	90	110
F	45	52	65	75	95	115	140	180	220
G - CNOMO (H14)	9	9	11	11	14	14	18	22	22
G - CETOP (H14)	7	9	9	9	12	14	16	18	22
G - ISO (H14)	7	9	9	9	12	14	16	18	22
H	8	8	10	10	12	12	16	20	20
I	7	7	9	9	11	11	13	17	17
M	35	35	45	45	55	55	68	82	91
N - CNOMO (±0,2)	27	27	35	35	43	43	52	62	62
N - CETOP - ISO (±0,2)	22	25,5	30	30	37	37,5	41	60	65
L3 - CNOMO	132	171	179	199	207	235	244	292	292
L3 - CETOP - ISO	144	163	175	190	215	230	270	320	345
L4 - CNOMO	134	164	180	195	211	231	249	304	304
L4 - CETOP - ISO	142	161	170	185	210	220	250	300	320
Weight g	55	70	150	175	260	550	920	2200	3200

Short sheet metal feet

Ordering code
1303.Ø.05/1F
(CNOMO - CETOP - ISO)
(1 piece)

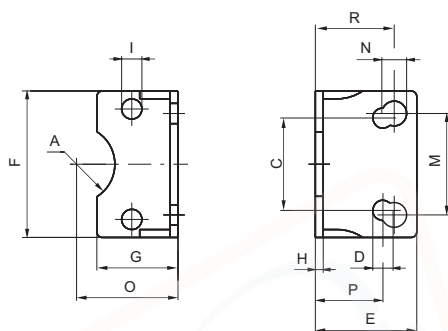
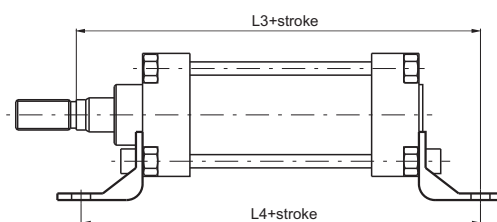

Elements used to anchor the cylinder parallel to the mounting plane. They are made of stamped and pierced sheet metal and painted in black. The mounting holes allow use with CNOMO, CETOP and ISO. Available up to 100 mm bore

Bore	32	40	50	63	80	100
A	13	17	17	23,5	23,5	-
C - CETOP - ISO (JS 14)	32	36	45	50	63	75
D - CETOP - ISO (JS 15)	7	9	9	9	12	14
E	35	36	45	45	55	56
F	45	52	65	75	95	115
G	30	30	36	35	45	44
H	3,5	3,5	3,5	4,5	5	5
I	7	7	9	9	11	11
M - CNOMO (JS 14)	28	36	45	55	70	90
N - CNOMO (JS 15)	9	9	11	11	13	13
O - CNOMO (JS 15)	32	36	45	50	63	73
O - CETOP - ISO (JS 15)	32	36	45	50	63	71
P - CETOP - ISO (±0,2)	22	25,5	30	30	37	37,5
R - CNOMO (±0,2)	27	27	35	35	43	43
L3 - CNOMO	132	171	179	199	207	235
L3 - CETOP - ISO	144	163	175	190	215	230
L4 - CNOMO	134	164	180	195	211	231
L4 - CETOP - ISO	142	161	170	185	210	220
Weight g	58	70	118	184	305	385

Large internal and external feet

Ordering code
Internal
1303.Ø.06F
(CNOMO) (1 piece)
(May be used with CETOP-ISO cylinders but are not specified in the standards)
External
1303.Ø.07F
(CNOMO) (1 piece)

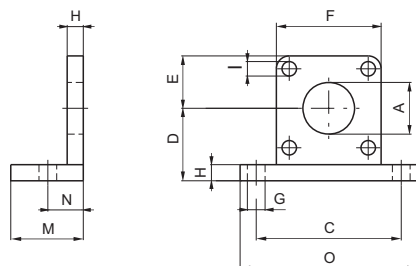
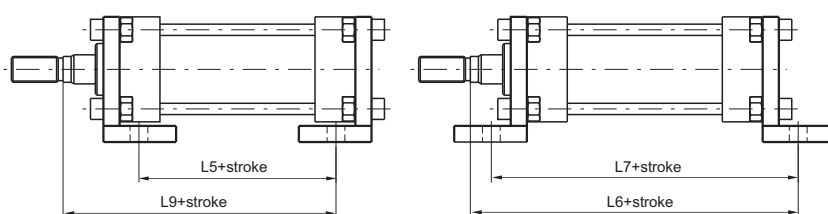

Elements used to anchor the cylinder parallel to the mounting plane. They are made of aluminium alloy and painted black.

Bore	32	40	50	63	80	100	125	160	200
A (H11)	25	32	32	45	45	55	55	65	65
C (JS 14)	65	72	90	100	126	148	180	230	270
D (JS 15)	32	36	45	50	63	73	91	115	135
E	22	26	32	37	47	57	70	90	110
F	45	52	65	75	95	115	140	180	220
G (H14)	9	9	11	11	14	14	18	22	22
H	8	8	10	10	12	12	16	20	20
I	7	7	9	9	11	11	13	17	17
M	35	35	45	45	55	55	67	80	80
N (±0,2)	18	18	22	22	28	28	32	40	40
O	82	90	110	120	155	180	215	275	315
L5 - CNOMO	60	90	86	101	93	113	113	140	140
L5 - CETOP - ISO	78	90	86	101	104	113	136	140	150
L6 - CNOMO	123	162	166	186	192	220	224	270	270
L6 - CETOP - ISO	141	162	166	186	203	220	247	270	280
L7 - CNOMO	116	146	154	169	181	201	209	260	260
L7 - CETOP - ISO	134	146	154	169	192	201	232	260	270
L9 - CNOMO	95	134	132	152	148	176	176	210	210
L9 - CETOP - ISO	112	128	133	148	162	176	213	240	250
Weight g	80	90	190	210	460	600	1080	2400	3100

Front clevis

Ordering code

Front
1303.Ø.08F
 (CNOMO)
1304.Ø.08F
 (CETOP - ISO)

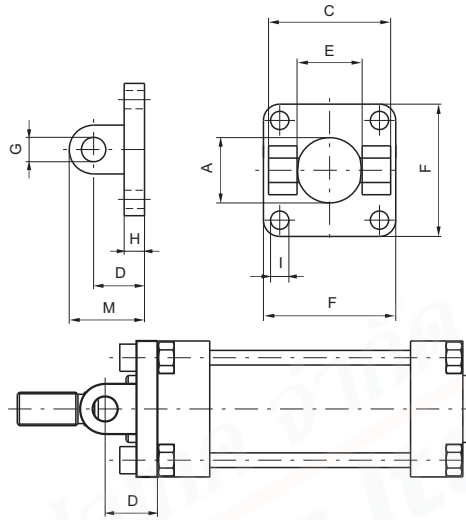

Bore	32	40	50	63	80	100	125	160	200
A	25	32	32	45	45	55	55	65	65
C - CNOMO (H1)	45	52	65	75	95	115	140	180	220
C - CETOP - ISO (H14)	45	52	60	70	90	110	130	170	170
D - CNOMO (±0,2)	18	24	26	30	32	37	41	55	55
D - CETOP (±0,2)	20	22	25	30	32	37	46	55	55
E - CNOMO (H14)	26	33	33	47	47	57	57	72	72
E - CETOP (H14)	26	28	32	40	50	60	70	90	90
F	45	52	65	75	95	115	140	180	220
G - CNOMO (H9)	8	12	12	16	16	20	20	25	25
G - CETOP - ISO (H9)	10	12	12	16	16	20	25	30	30
H	8	8	10	10	12	12	16	19	19
I	7	7	9	9	11	11	13	17	17
M - CNOMO	26	36	38	46	48	57	61	80	80
M - CETOP - ISO	30	35	37	46	48	57	71	85	85
Weight g	55	60	120	145	325	510	900	2080	3100

This type of mounting allows anchorage of the cylinder both parallel and at a right angle to the plane; the cylinder rod can oscillate and self-align as necessary. It is made of aluminium alloy and painted black.

Rear clevis complete with pin

Ordering code

Rear
1303.Ø.09F
 (CNOMO)
1304.Ø.09F
 (CETOP - ISO)

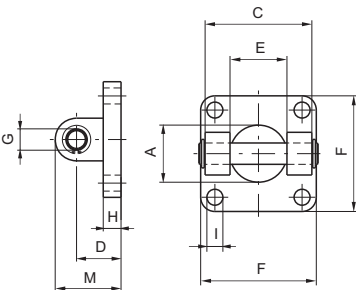
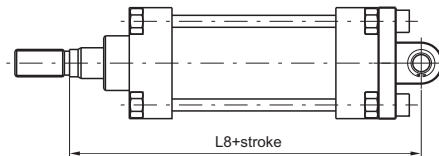

Bore	32	40	50	63	80	100	125	160	200
A	25	32	32	45	45	55	55	65	65
C - CNOMO (H1)	45	52	65	75	95	115	140	180	220
C - CETOP - ISO (H14)	45	52	60	70	90	110	130	170	170
D - CNOMO (±0,2)	18	24	26	30	32	37	41	55	55
D - CETOP - ISO (±0,2)	20	22	25	30	32	37	46	55	55
E - CNOMO (H14)	26	33	33	47	47	57	57	72	72
E - CETOP (H14)	26	28	32	40	50	60	70	90	90
F	45	52	65	75	95	115	140	180	220
G - CNOMO (H9)	8	12	12	16	16	20	20	25	25
G - CETOP - ISO (H9)	10	12	12	16	16	20	25	30	30
H	8	8	10	10	12	12	16	19	19
I	7	7	9	9	11	11	13	17	17
M - CNOMO	26	36	38	46	48	57	61	80	80
M - CETOP - ISO	30	35	37	46	48	57	71	85	85
L8 - CNOMO	123	168	170	194	196	229	233	285	285
L8 - CETOP - ISO	142	160	170	190	210	230	275	315	335
Weight g	75	110	190	280	490	820	1270	2800	3900

This type of mounting allows anchorage of the cylinder both parallel and at a right angle to the plane; the cylinder rod can oscillate and self-align as necessary. It is made of aluminium alloy and painted black.

Rear male clevis

Ordering code
1304.Ø.09/1F
(For CETOP-ISO cylinders
May be used with CNOMO cylinders but is not specified in the standards)

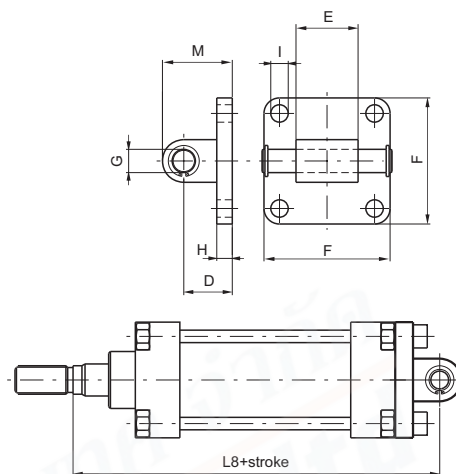

Similar to 09 clevis except for the connection, which is male rather than female. It can also be used as a counter clevis for type 10 (only CETOP - ISO). Allows mounting of cylinder at right angle to the plane of the cylinder rod.

Bore	32	40	50	63	80	100	125	160	200
D ($\pm 0,2$)	20	22	25	30	32	37	46	55	55
E ($^{+0,2}_{-0,6}$)	26	28	32	40	50	60	70	90	90
F	45	52	65	75	95	115	140	180	220
G (H 9)	10	12	12	16	16	20	25	30	30
H	8	8	8	10	12	12	16	20	20
I	7	7	9	9	11	11	14	18	18
M	30	35	36	45	47	57	71	80	80
L8 - CNOMO	125	166	169	194	196	229	233	285	285
L8 - CETOP - ISO	142	160	170	190	210	230	275	315	335
Weight g	50	80	110	185	325	460	1300	2850	3980

Rear clevis bracket

Ordering code
1303.Ø.10F (CNOMO)
(May be used with CETOP - ISO cylinders but is not specified in the standard)

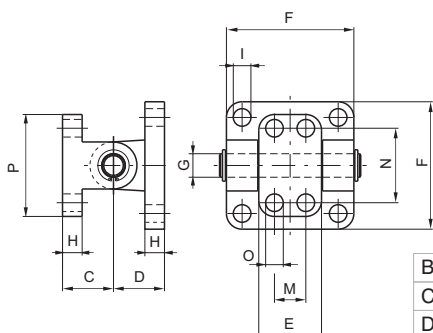
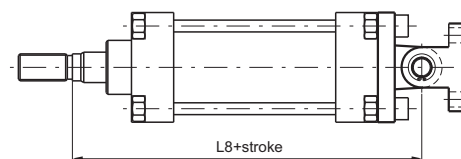

Mounting consists of clevis 09 and counter clevis. Used to mount cylinders at a right angle to the plane to which the counter clevis is attached. Allows self-alignment of the cylinder rod under load with an oscillation of ± 60 degrees.

Bore	32	40	50	63	80	100	125	160	200
C ($\pm 0,2$)	18	26	26	34	34	41	41	55	55
D ($\pm 0,2$)	18	24	26	30	32	37	41	55	55
E	25	32	32	46	46	56	56	71	71
F	45	52	65	75	95	115	140	180	220
G (H 9)	8	12	12	16	16	20	20	25	25
H	8	10	10	12	12	16	16	20	20
I	7	7	9	9	11	11	13	17	17
M (JS 14)	-	16	16	25	25	32	32	43	43
N (JS 14)	28	38	38	54	54	90	90	150	150
O (H 13)	7	9	9	11	11	14	14	18	18
P	40	52	52	75	75	115	115	180	180
L8 - CNOMO	123	168	170	194	196	229	233	285	285
L8 - CETOP - ISO	140	162	171	190	210	229	270	315	335
Weight g	90	165	240	470	665	1190	1660	3700	4700

Trunnion with support bracket

Ordering code

1303.Ø.11F (CNOMO)
 (May be used with
 CETOP - ISO
 cylinders but
 is not specified
 in the standards)

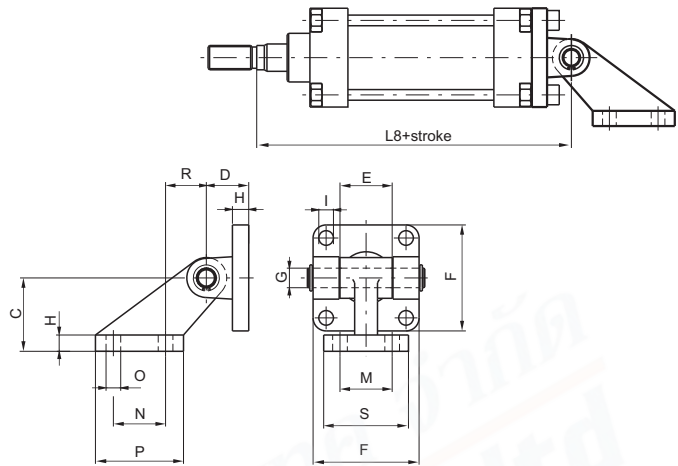

Bore	32	40	50	63	80	100	125	160	200
C (JS 15)	32	45	45	63	63	90	90	140	140
D (±0,2)	18	24	26	30	32	37	41	55	55
E	25	32	32	46	46	56	56	71	71
F	45	52	65	75	95	115	140	180	220
G (H9)	8	12	12	16	16	20	20	25	25
H	8	10	10	12	12	16	16	20	20
I	7	7	9	9	11	11	13	17	17
M (JS14)	25	32	32	40	40	50	50	63	63
N (Js14)	20	32	32	50	50	70	70	110	110
O (JS 13)	7	9	9	11	11	14	14	18	18
P	37	54	54	75	75	102	102	154	154
R	18	25	25	32	32	40	40	50	50
S	41	51	51	62	62	80	80	110	110
L8 - CNOMO	123	168	170	194	196	229	233	285	285
L8 - CETOP - ISO	140	162	171	190	210	229	270	315	335
Weight g	125	250	325	600	800	1570	2100	4600	5700

Mounting consists of clevis 09 and right angle counter clevis. Used to mount cylinders parallel to the plane to which the counter clevis is attached. Allows self-alignment of the cylinder rod under load with an oscillation up to 90 degrees from the mounting plane.

Intermediate trunnion

Ordering code

1300.Ø.12F

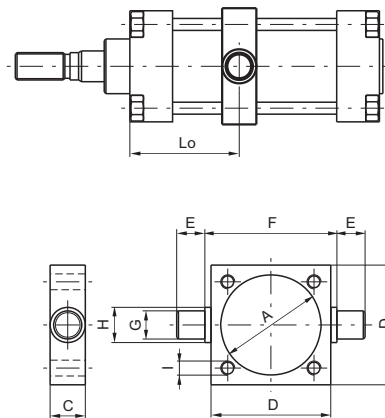
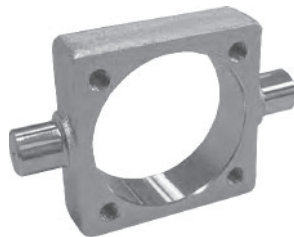

Bore	32	40	50	63	80	100	125	160	200
A	37	46	56	69	87	107	133	170	211
C	15	20	20	25	25	30	32	40	40
D	46	59	69	84	102	125	155	190	240
E (h 14)	12	16	16	20	20	25	25	32	32
F (h 14)	50	63	73	90	108	131	160	200	250
G (e 9)	12	16	16	20	20	25	25	32	32
H	15	20	20	25	25	30	30	40	40
I	M6	M6	M8	M8	M10	M10	M12	M16	M16
Lo min.	32	35	40	47	53	55	61	78	79
Lo max. + stroke - CNOMO	48	75	70	80	72	90	84	103	102
Lo max. + stroke - CETOP - ISO	67	75	70	80	84	90	107	103	112
Weight g	130	310	370	700	900	1590	2600	4300	7500

Clevis to be mounted between the endcaps of the cylinder allowing rotation at any point along the barrel. One piece construction from zinc-plated stamped steel. Can be mounted in fixed position or attached to adjustable tie rods.
 NOTE: Lo max means at stroke 0.

Fork with pin

Ordering code
1300.Ø.13F (CNOMO)
1301.Ø.13F (CETOP)
1302.Ø.13F (ISO)

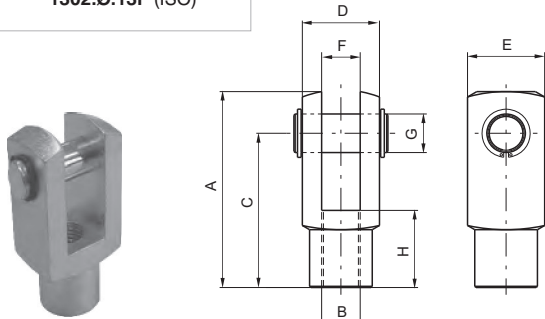

Male fork

Ordering code
1300.Ø.14F
(only for CNOMO cylinders)

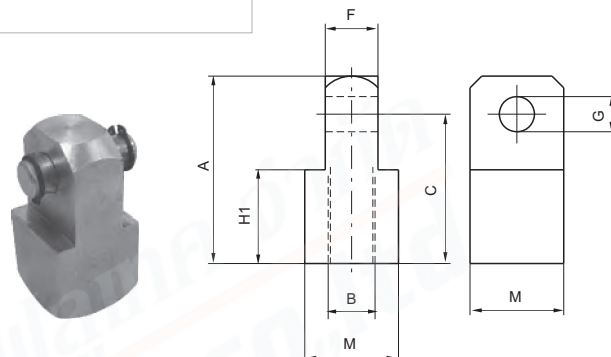

Fork with clips

Ordering code
1300.Ø.13/1F (CNOMO)
1301.Ø.13/1F (CETOP)
1302.Ø.13/1F (ISO)

from Ø32 to Ø100 mm

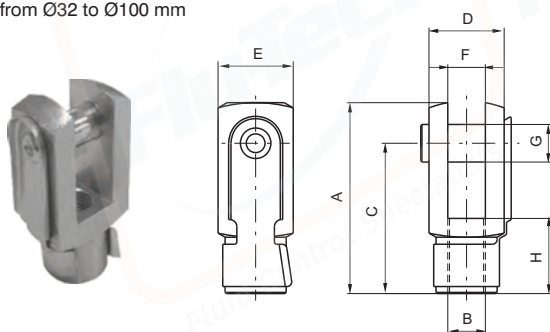

Rod lock nut

Ordering code
1300.Ø.18F (CNOMO)
1301.Ø.18F (CETOP)
1302.Ø.18F (ISO)

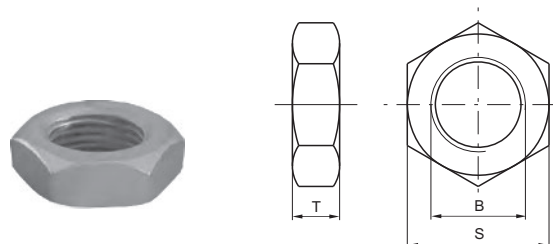

Bore	32	40	50	63	80	100	125	160	200
A - CNOMO	45	64	64	80	80	105	105	140	140
A - CETOP - ISO	51	62	82	82	105	105	132/148	188	188
B - CNOMO (6H)	M10x1,5	M16x1,5	M16x1,5	M20x1,5	M20x1,5	M27x2	M27x2	M36x2	M36x2
B - CETOP (6H)	M10x1,25	M12x1,25	M16x1,5	M16x1,5	M20x1,5	M20x1,5	M24x2	M36x2	M36x2
B - ISO (6 H)	M10x1,25	M12x1,25	M16x1,5	M16x1,5	M20x1,5	M20x1,5	M27x2	M36x2	M36x2
C - CNOMO	36	51	51	63	63	85	85	115	115
C - CETOP - ISO	40	48	64	65	80	80	100/100	144	144
D - CNOMO	22	36	36	45	45	63	63	80	80
D - CETOP - ISO	20	24	32	32	40	40	50/55	70	70
E - CNOMO	22	26	26	34	34	42	42	50	50
E - CETOP - ISO	20	24	32	32	40	40	50/55	70	70
F - CNOMO (H 14)	11	18	18	22	22	30	30	40	40
F - CETOP - ISO (B 12)	10	12	16	16	20	20	25/30	35	35
G - CNOMO (H 9)	8	12	12	16	16	20	20	25	25
G - CETOP - ISO (H 9)	10	12	16	16	20	20	25/30	35	35
H - CNOMO	20	26	26	30	30	45	45	75	75
H - CETOP - ISO	20	24	32	32	40	40	50/56	72	72
H1 - CNOMO	20	32	32	40	40	55	55	75	75
M	22	32	32	36	36	45	45	70	70
S - CNOMO	17	24	24	30	30	41	41	55	55
S - CETOP	17	19	24	24	30	30	36	55	55
S - ISO	17	19	24	24	30	30	41	55	55
T - CNOMO	6	8	8	9	9	12	12	18	18
T - CETOP	6	7	8	8	9	9	10	18	18
T - ISO	6	7	8	8	9	9	12	18	18
Weight g									
Fork	90	150	350	350	680	680	2500	4000	4000
Rod lock nut	10	20	20	35	35	80	80	210	210
Male fork	110	30	330	500	500	1300	1300	3500	3500