

Guide cylinders



Ordering code

6700.Ø.stroke

- 10
- 16
- 20

Construction characteristics

Body	anodised aluminium
Piston rod	stainless steel
Piston	aluminium
Piston rod bushing	aluminium
End cap	anodised aluminium
Seals	oil resistant NBR rubber
Table	anodised aluminium

Standard strokes

Bore	Stroke								
	5	10	15	20	25	30	40	50	60
Ø10	●	●	●	●	●	●	●	●	●
Ø16	●	●	●	●	●	●	●	●	●
Ø20	●	●	●	●	●	●	●	●	●

Operational characteristics

Fluid	Filtered air. No lubrication needed, if applied it shall be continuous.
Working pressure	1.2 - 7 bar
Working temperature	-5°C - +70°C
Cushioning	with elastic bumper

Theoretical force

Bore	Effective area (mm²)	Force (N)						
		2	3	4	5	6	7	
Ø10	Out	28,3	5,7	8,5	11,3	14,2	17	19,8
	In	21,2	4,2	6,4	8,5	10,6	12,7	14,8
Ø16	Out	78,5	15,7	23,6	31,4	39,3	47,1	55
	In	66	13,2	19,8	26,4	33	39,6	46,2
Ø20	Out	314	62,8	94,2	125,6	157	188,4	219,8
	In	264	52,8	79,2	105,6	132	158,4	184,8
		Working pressure (bar)						

Overall dimensions - Ø10

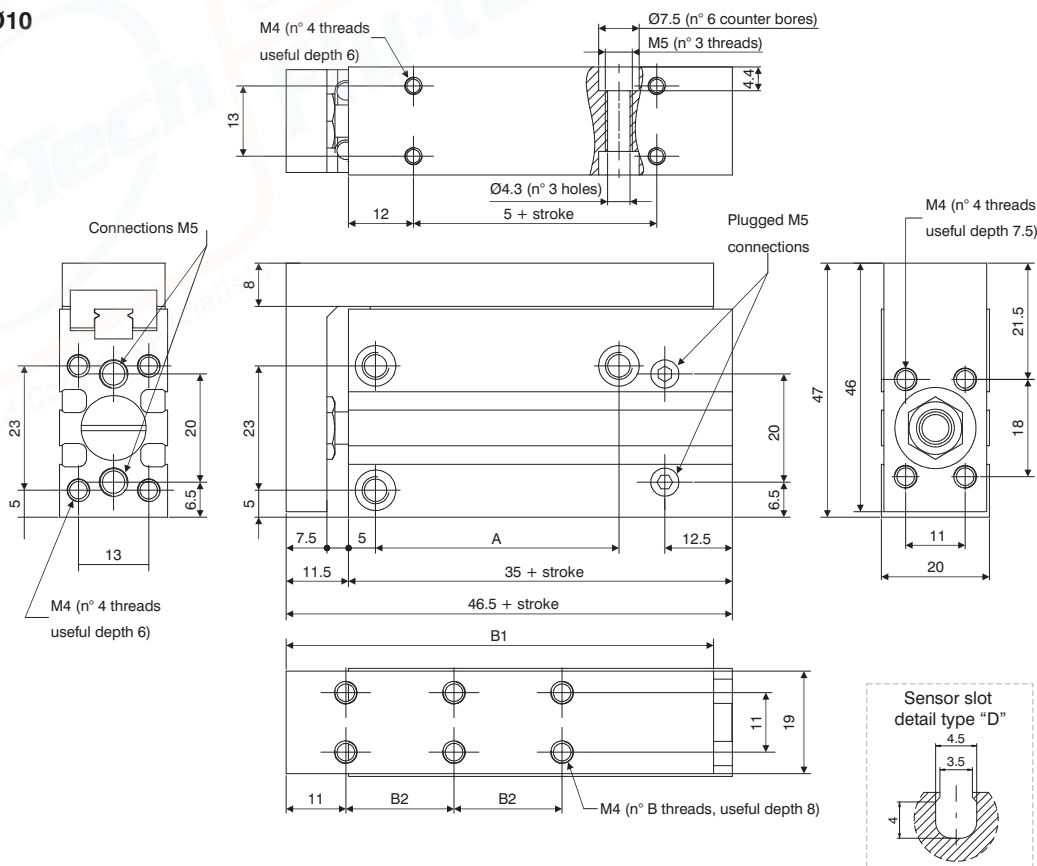

Table of dimensions

	Standard strokes								
	5	10	15	20	25	30	40	50	60
A	14	24	30	45	45	60			
B1	49	59	69	79	79	99			
B2	10	20	30	20	20	30			
B	4					6			
Weight (g)	117	125	140	148	162	170	192	215	238

3

PNEUMATIC ACTUATION

Overall dimensions - Ø16

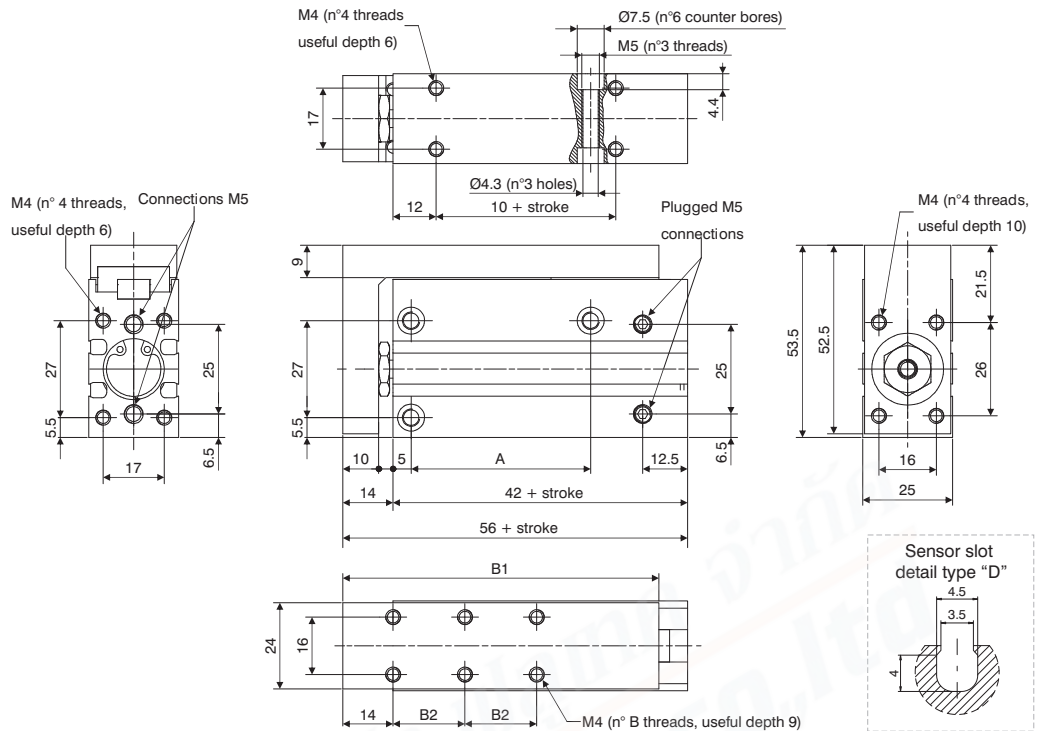

Table of dimensions

	Standard strokes								
	5	10	15	20	25	30	40	50	60
A	20	30	40	50	60				
B1	58	68	78	88	98	108			
B2	10	20	30	20	25	30			
B	4								
Weight (g)	215	230	250	260	280	290	325	350	390

Overall dimensions - Ø20

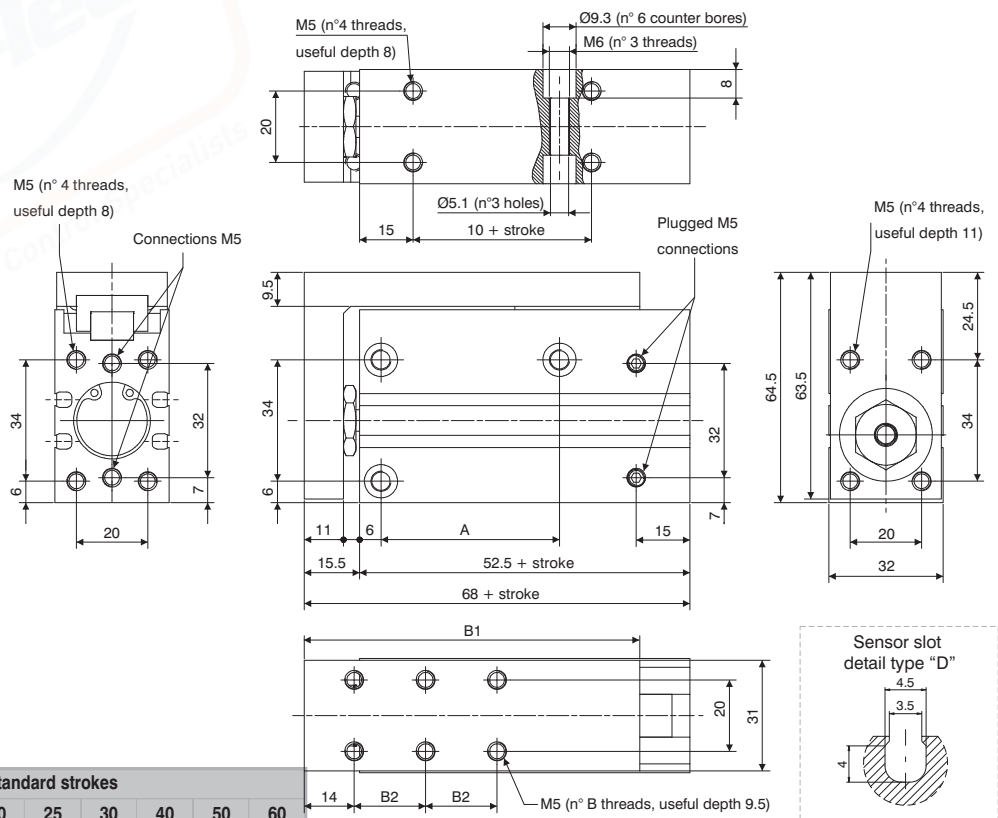
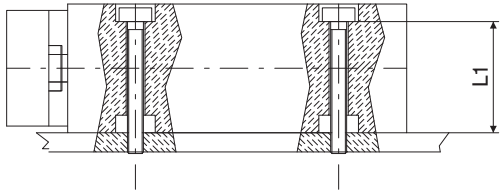

Table of dimensions

	Standard strokes								
	5	10	15	20	25	30	40	50	60
A	20	25	40	50	70				
B1	64	74	84	94	104	114			
B2	10	20	30	20	25	30			
B	4								
Weight (g)	440	455	490	505	540	560	600	660	700

Fixing - Load

LATERAL (THROUGH SCREW)



	SCREW	Maximum torque (Nm)	L1
Ø10	M4	2.5	15.6
Ø16	M4	2.5	20.6
Ø20	M5	5.1	24

LATERAL (THREADED HOLE)

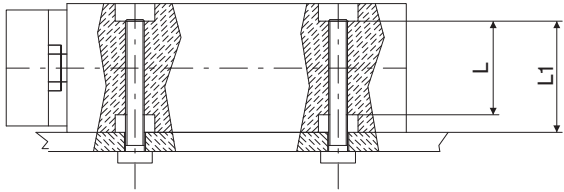

	SCREW	Maximum torque (Nm)	L1	L
Ø10	M5	5.1	15.6	11.2
Ø16	M5	5.1	20.6	16.2
Ø20	M6	8.1	24	16

VERTICAL (THREADED HOLE)

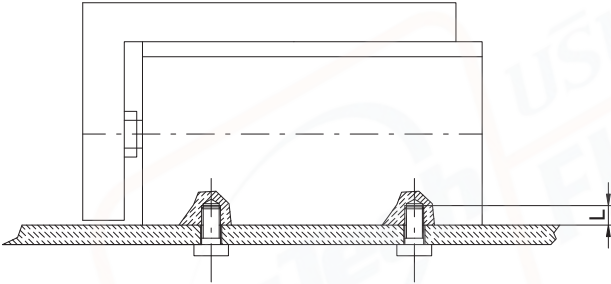

	SCREW	Maximum torque (Nm)	L
Ø10	M4	2.5	6
Ø16	M4	2.5	6
Ø20	M5	5.1	8

AXIAL (THREADED HOLE)

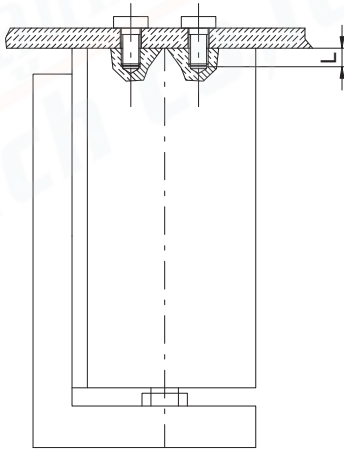

	SCREW	Maximum torque (Nm)	L
Ø10	M4	2.5	6
Ø16	M4	2.5	6
Ø20	M5	5.1	8

LOAD

FRONTAL MOUNTING

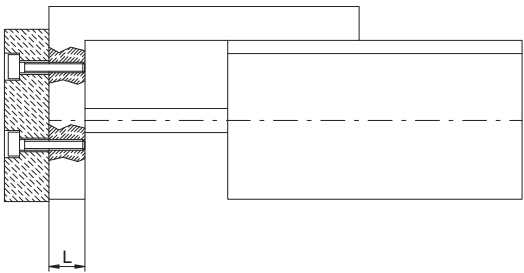

	SCREW	Maximum torque (Nm)	L
Ø10	M4	2.5	7.5
Ø16	M4	2.5	10
Ø20	M5	5.1	11

BACK MOUNTING

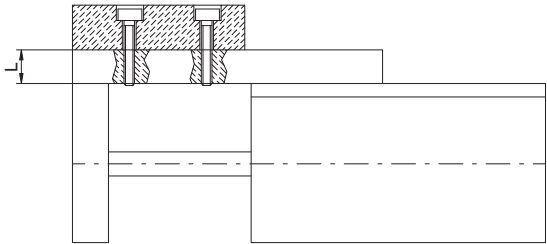

	SCREW	Maximum torque (Nm)	L
Ø10	M4	2.5	8
Ø16	M4	2.5	9
Ø20	M5	5.1	9.5

Fixing - Load

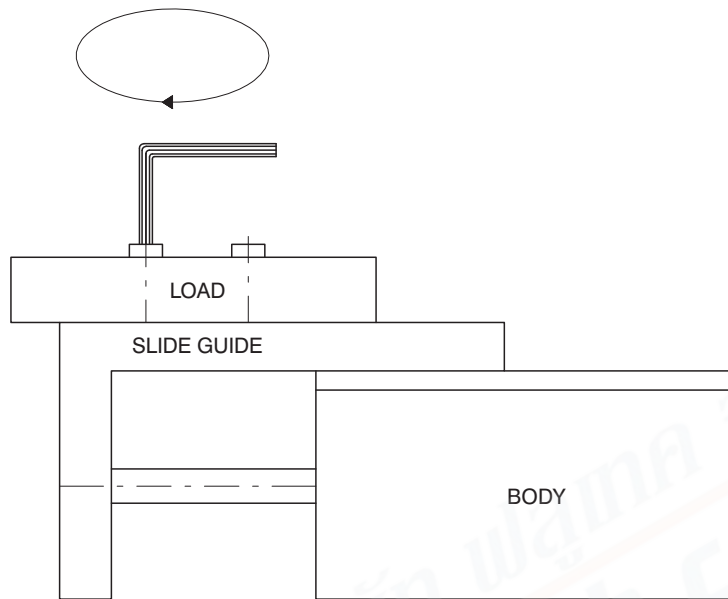

ATTENTION : Slide must be blocked before fixing the load  
this operation should not be done by blocking the body as the  
guide could get damaged.

3  
PNEUMATIC ACTUATION

CONNECTION BETWEEN PLATE AND ROD

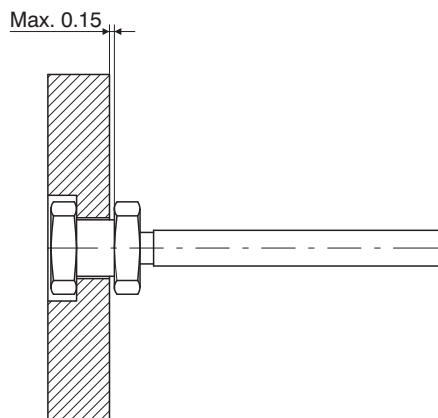

The fluctuating connection, maximum clearance 0.15mm as indicated by the arrow



Plate deflection graphs

Plate deviation (arrow) when the load is applied on the spot indicated with the arrow and the unit completely extended

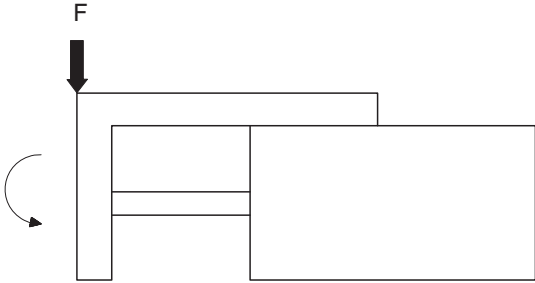
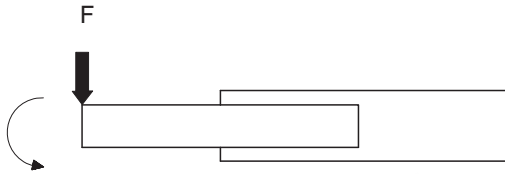
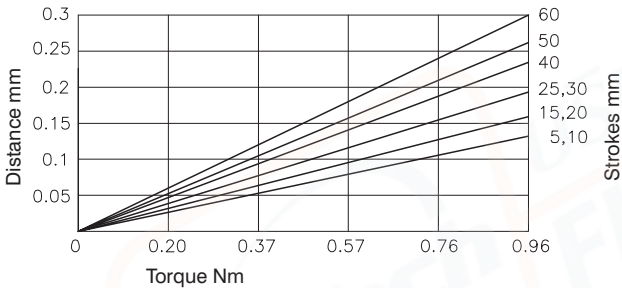

Plate deviation (arrow) when the load is applied on the spot indicated with the arrow and the unit completely extended



Ø10



Ø10

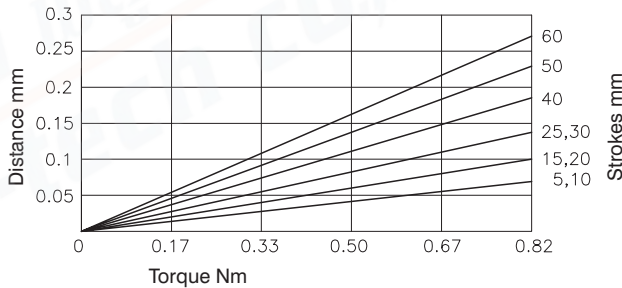

Ø16

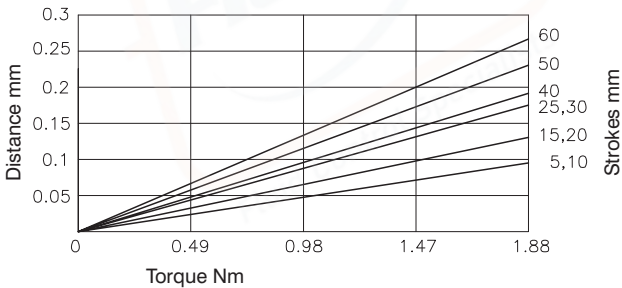

Ø16

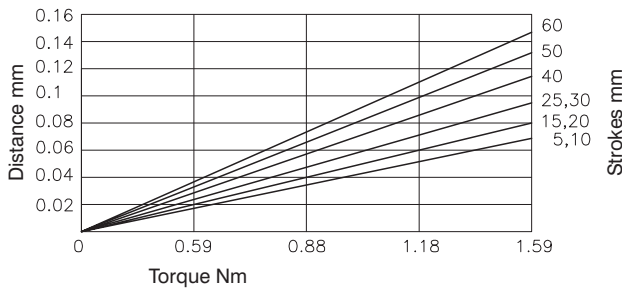

Ø20

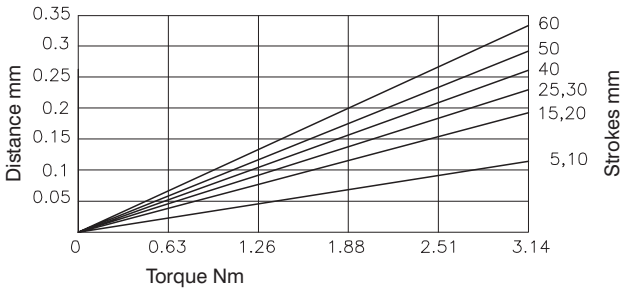

Ø20

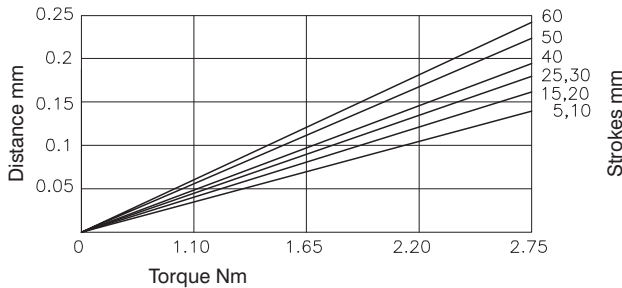

**Plate deflection graphs outer stroke - selection graphs**

Plate deviation (compared to A) when the load is applied on the spot indicated with the arrow and the unit completely extended

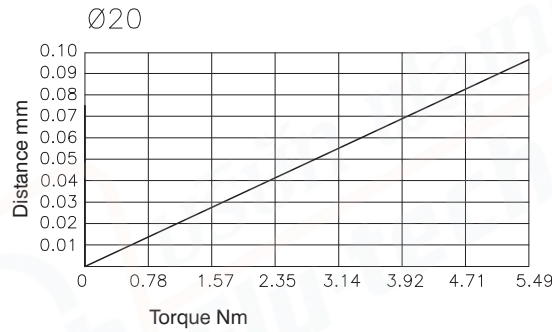
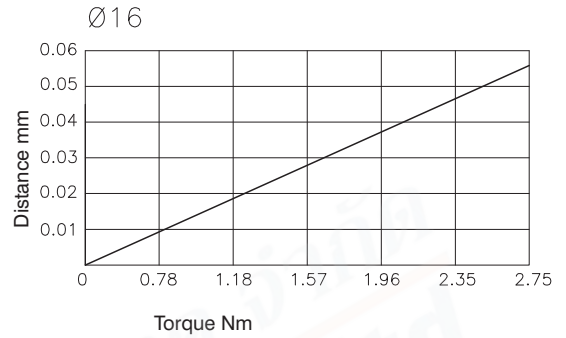
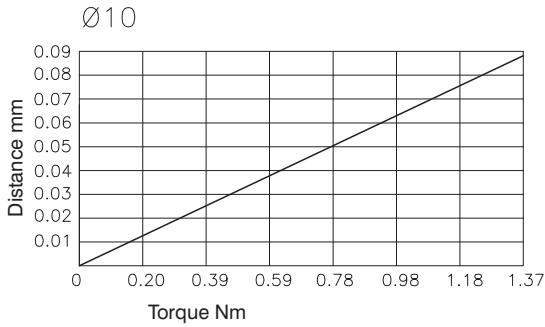
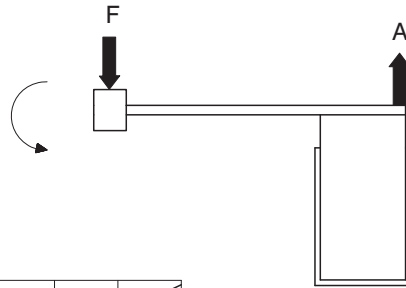

MOUNTING POSITION	VERTICAL			HORIZONTAL								
	100	200	300	100			200			300		
MAX. SPEED (mm/sec.)	100	200	300	50	100	200	50	100	200	50	100	200
Load eccentricity				50	100	200	50	100	200	50	100	200
Selection graphs	1	2	3	4	5	6	7	8	9	10	11	12

**Selection graphs 1 - 3 (vertical mounting)**

Drawing 1

Maximum speed 100 mm/s or lower

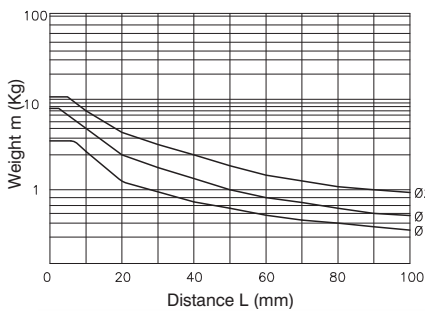

Drawing 2

Maximum speed 300 mm/s or lower

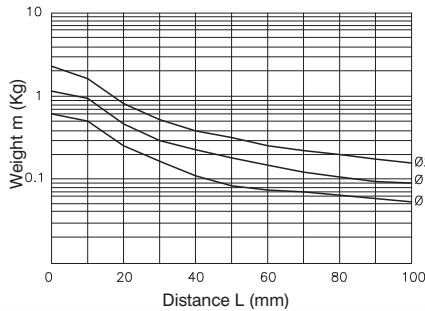

Drawing 3

Maximum speed 500 mm/s or lower

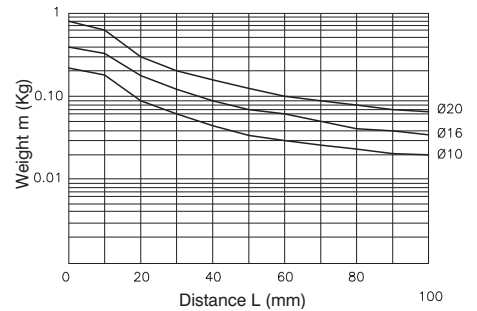



Selection graphs

Selection graphs 4 - 12 (horizontal mounting)

Drawing 4 load eccentricity 50mm  
Maximum speed 100 mm/s or lower

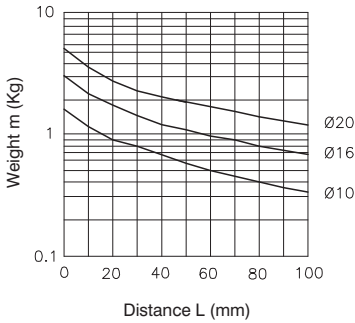

Drawing 7 load eccentricity 50mm  
Maximum speed 300 mm/s or lower

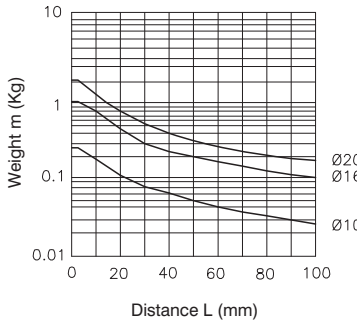

Drawing 10 load eccentricity 50mm  
Maximum speed 500 mm/s or lower

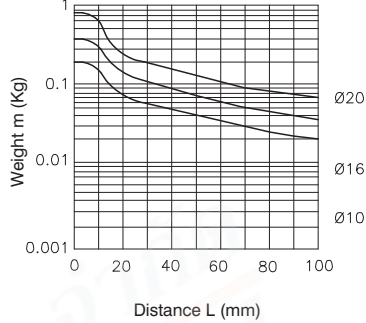

Drawing 5 load eccentricity 100mm  
Maximum speed 100 mm/s or lower

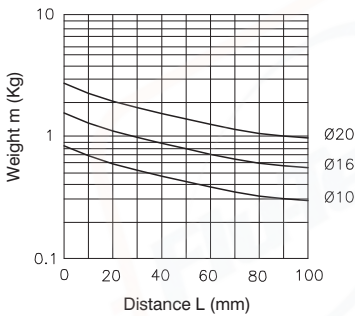

Drawing 8 load eccentricity 100mm  
Maximum speed 300 mm/s or lower

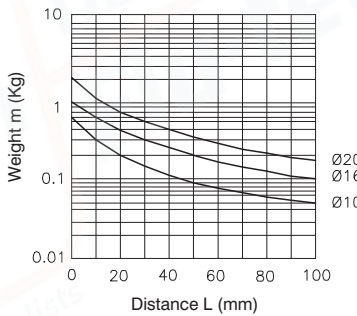

Drawing 11 load eccentricity 100mm  
Maximum speed 500 mm/s or lower

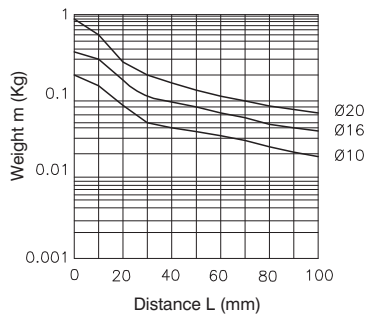

Drawing 6 load eccentricity 200mm  
Maximum speed 100 mm/s or lower

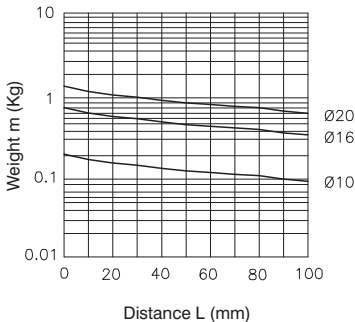

Drawing 9 load eccentricity 200mm  
Maximum speed 300 mm/s or lower

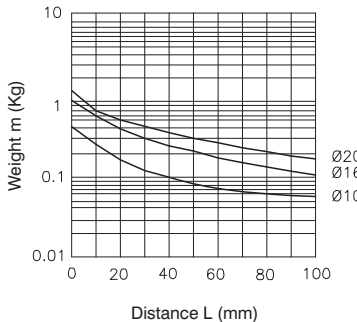

Drawing 12 load eccentricity 200mm  
Maximum speed 500 mm/s or lower

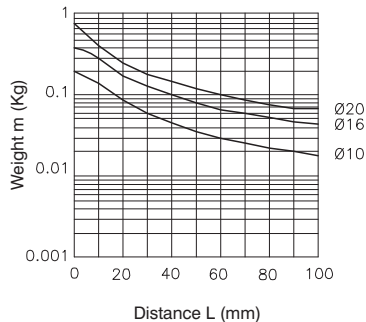

3  
PNEUMATIC ACTUATION

