

Slide cylinders

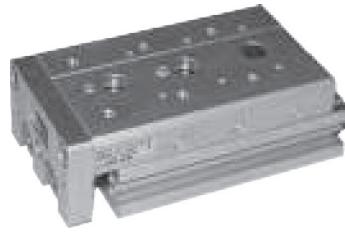

Ordering code

6600.Ø.stroke. \_ \_ \_

- 8
- 12
- 16
- 20
- 25

- = Without accessories
- A** = Double regulation end stroke
- AU** = Regulation front end stroke
- AR** = Regulation rear end stroke
- D** = Double shock absorber
- DU** = Front shock absorber
- DR** = Rear shock absorber

Construction characteristics

Body	anodised aluminium
Piston rod	stainless steel
Piston	stainless steel
Piston rod bushing	sintered bronze
End cap	anodised aluminium
Cushioning washer	PUR
Seal	oil resistant NBR rubber
Flange	anodised aluminium
Upper plate	anodised aluminium

Operational characteristics

Fluid	Filtered air. No lubrication needed, if applied it shall be continuous.
Working pressure	1.5 - 7 bar
Working temperature	-5°C - +70°C
Cushioning	with elastic bumper

Theoretical force

Bore	Effective area (mm <sup>2</sup> )	Force (N)						
		2	3	4	5	6	7	
Ø8	Out	101	20	30	40	51	61	71
	In	75	15	23	30	38	45	53
Ø12	Out	226	45	68	90	113	136	158
	In	170	34	51	68	85	102	119
Ø16	Out	402	80	121	161	201	241	281
	In	302	60	91	121	151	181	211
Ø20	Out	628	126	188	251	314	377	440
	In	471	94	141	188	236	283	330
Ø25	Out	982	196	295	393	491	589	687
	In	756	151	227	302	378	454	529

Standard strokes

Bore	Stroke								
	10	20	30	40	50	75	100	125	150
Ø8	●	●	●	●	●	●			
Ø12	●	●	●	●	●	●	●		
Ø16	●	●	●	●	●	●	●	●	
Ø20	●	●	●	●	●	●	●	●	●
Ø25	●	●	●	●	●	●	●	●	●

Overall dimensions Ø8

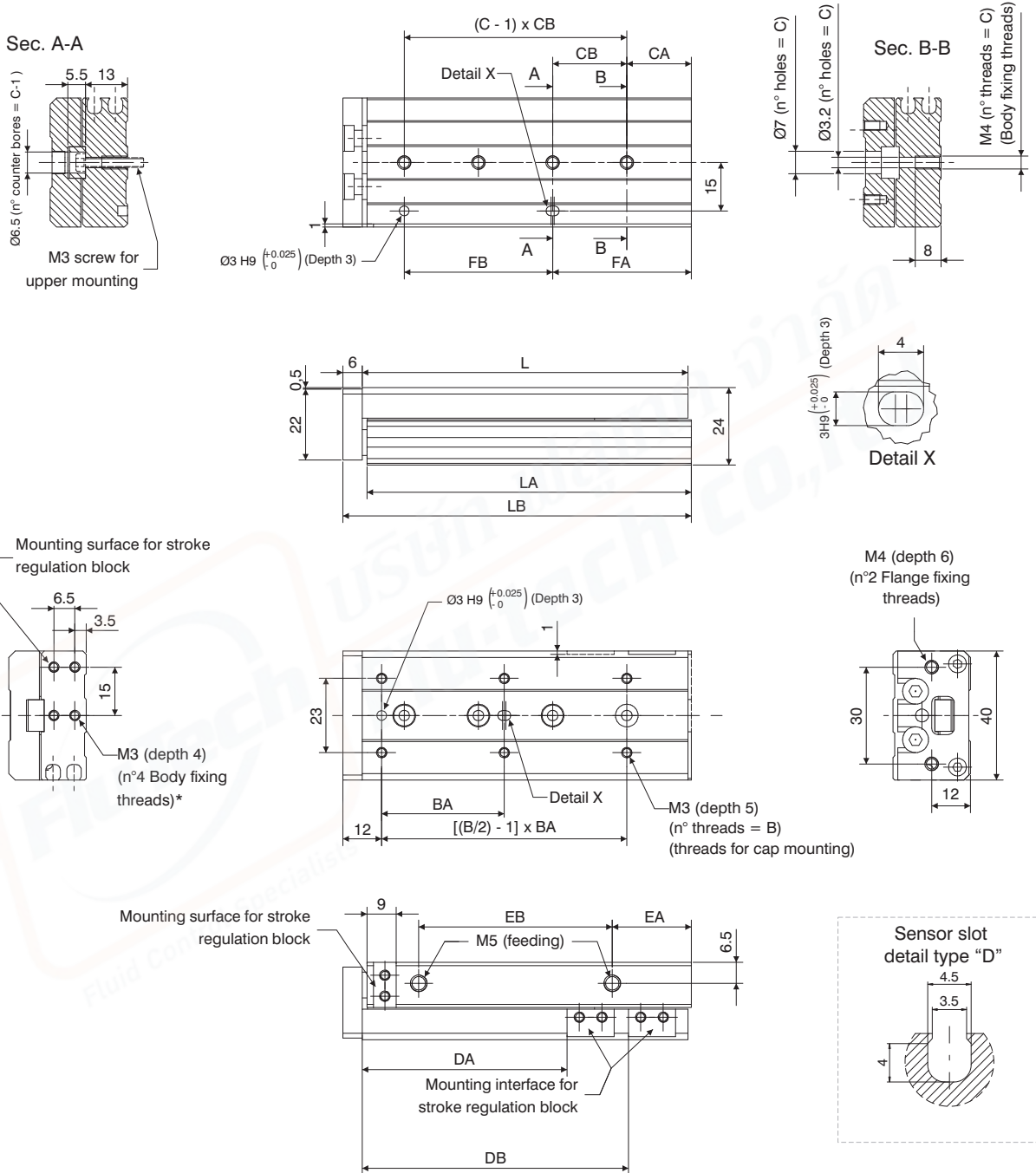
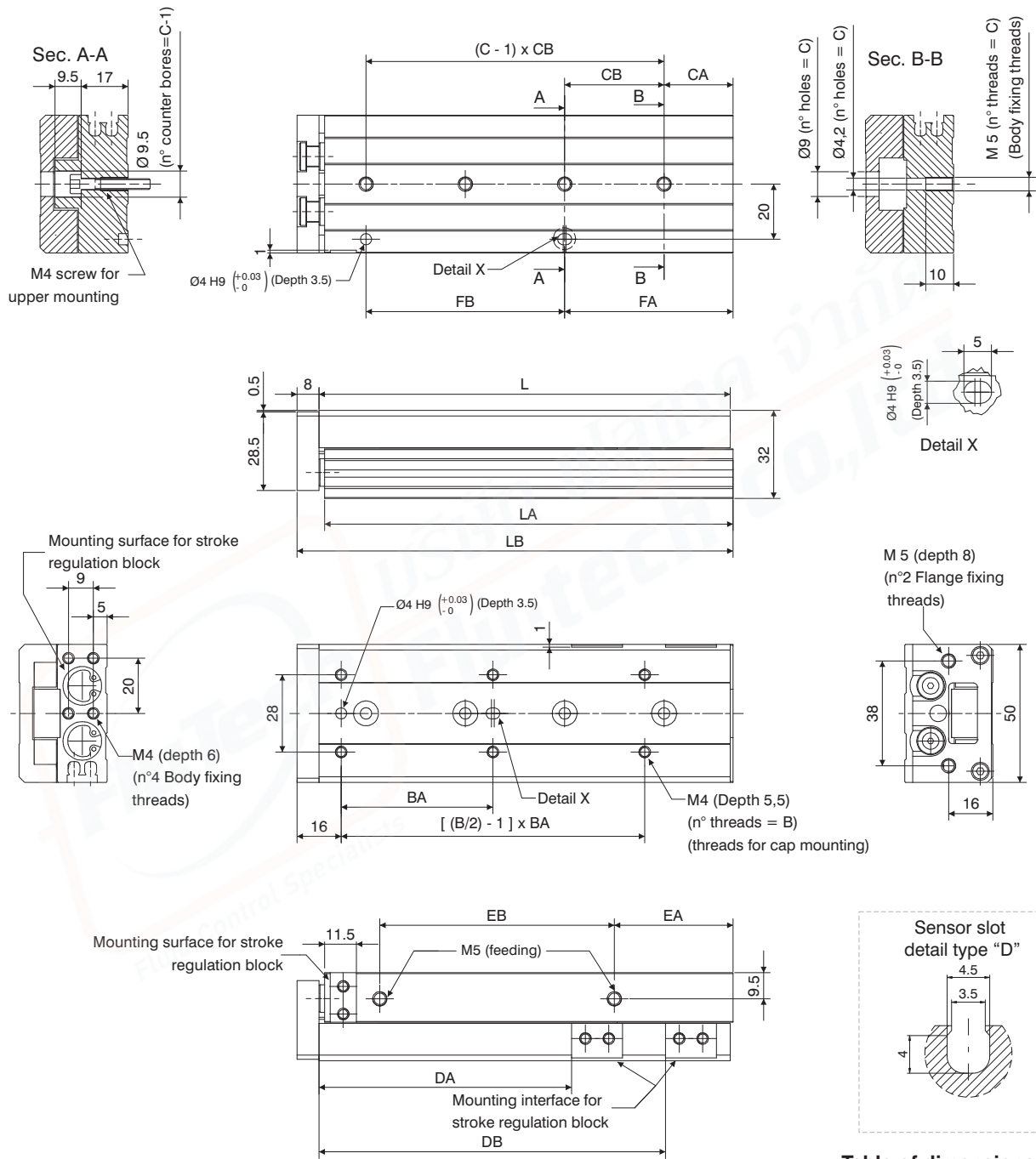

Table of dimensions

	Standard stroke					
	10	20	30	40	50	75
B	4	4	4	4	6	6
BA	25	25	40	50	38	50
C	2	2	3	3	4	5
CA	9	12	13	15	20	27
CB	28	30	20	28	23	28
DA	23,5	33,5	43,5	53,5	63,5	88,5
DB	/	/	/	/	82,5	132,5
FA	17	12	33	43	43	83
FB	20	30	20	28	46	56
EA	13	8,5	9,5	10,5	24,5	38,5
EB	19,5	29	39	56	60	96
L	49	54	65	83	101	151
LA	48,5	53,5	64,5	82,5	100,5	150,5
LB	56	61	72	90	108	158
<b>Weight g</b>	150	160	190	235	285	410

**Overall dimensions Ø12**



**Table of dimensions**

	Standard stroke							
	10	20	30	40	50	75	100	
B	4				6			
BA		35		50	35	55	65	
C		2		3	3	4	5	
CA		15		17	15	25	35	
CB		40		25	36	36	38	
DA	26,5	36,5	46,5	56,5	66,5	91,5	116,5	
DB	/	/	/	/	/	125,5	179,5	
FA		15		42	51	61	111	
FB		40		25	36	72	76	
EA		10			22	43	52	
EB		40		52	60	85	130	
L		71		83	103	149	203	
LA		70		82	102	148	202	
LB		80		92	112	158	212	
<b>Weight (gr.)</b>		325		385	480	660	890	



Overall dimensions Ø20

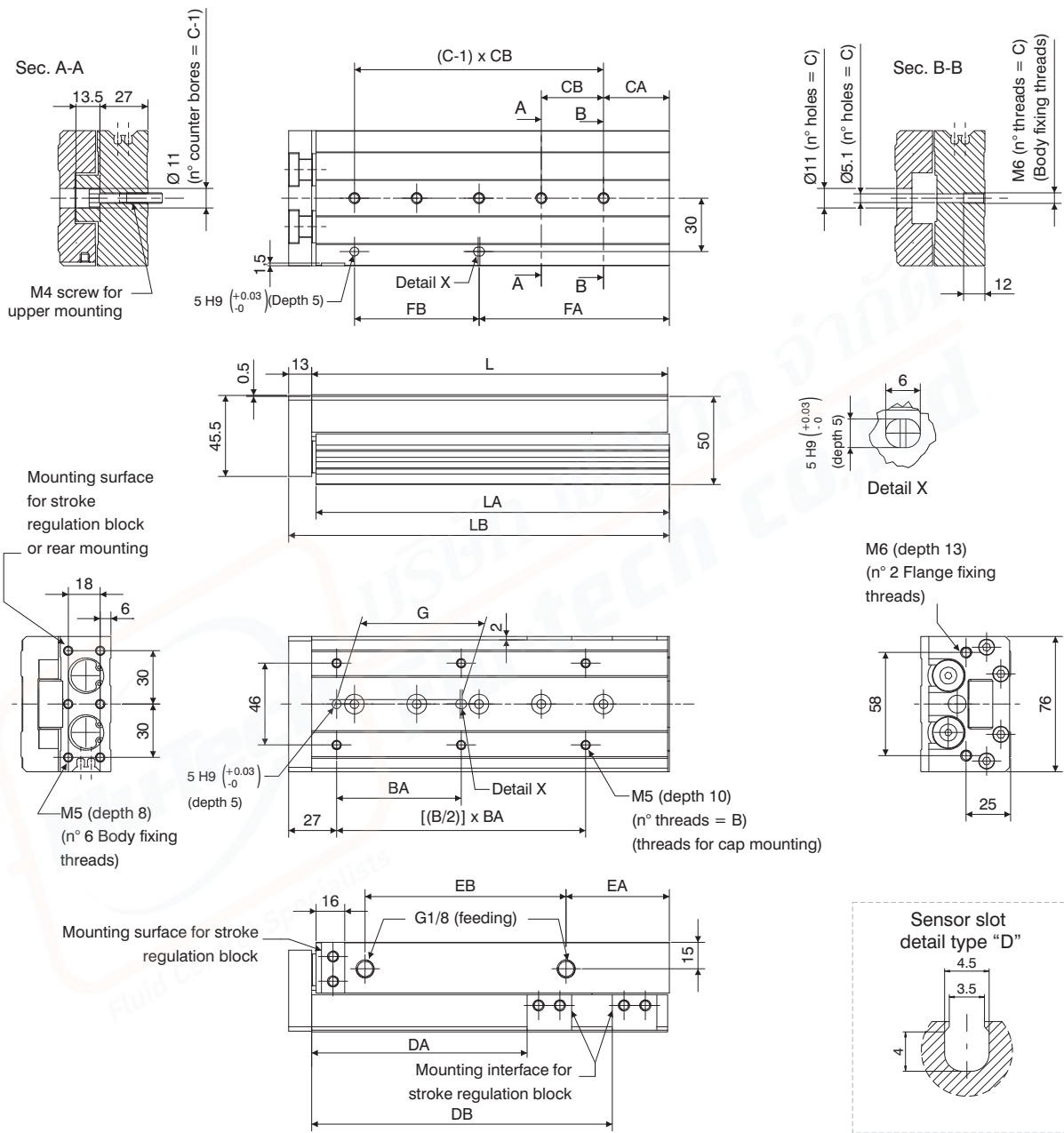

Table of dimensions

	Standard stroke									
	10	20	30	40	50	75	100	125	150	
B	4	4	4	4	6	6	6	8	8	
BA	50	50	50	60	35	60	70	70	80	
C	2	2	2	2	3	4	5	6	7	
CA	15	15	15	15	15	19	37	41	19	
CB	45	45	45	55	35	35	35	38	44	
DA	31	41	51	61	71	96	121	146	171	
DB	/	/	/	/	/	/	169	223	275	
EA	10	10	10	10	10	10	58	70	87	
EB	44	44	44	54	69	108	113	155	190	
FA	25	25	25	35	50	54	107	155	195	
FB	35	35	35	35	35	70	70	76	88	
G	40	40	40	50	35	60	70	70	80	
L	83	83	83	93	108	147	200	254	306	
LA	81,5	81,5	81,5	91,5	106,5	145,5	198,5	252,5	304,5	
LB	97	97	97	107	122	161	214	268	320	
Weight (gr.)	960	980	1010	1100	1250	1630	2150	2670	3190	

Overall dimensions Ø25

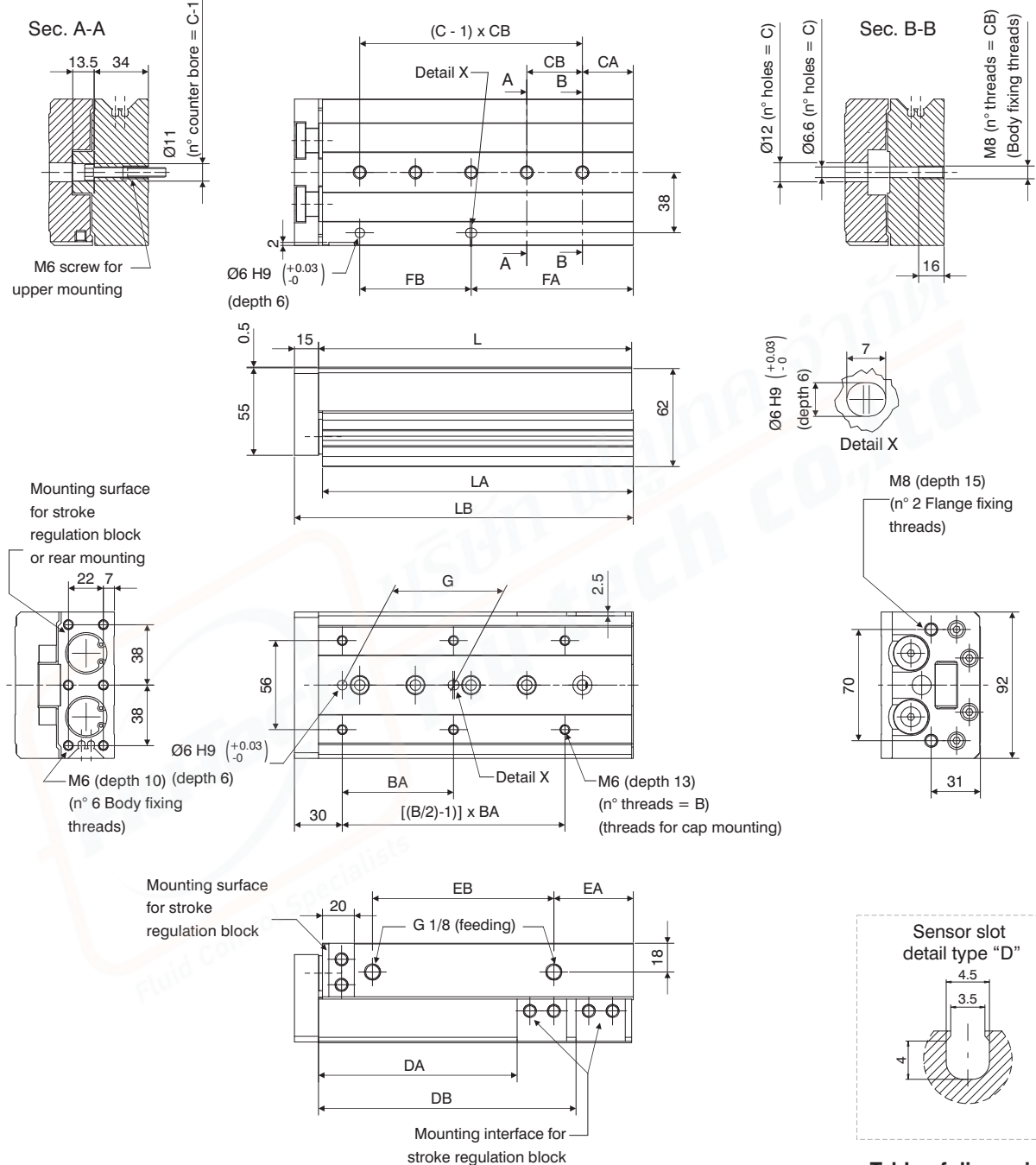
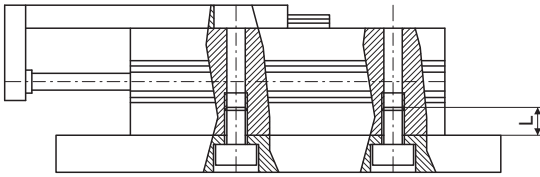

Table of dimensions

	Standard stroke								
	10	20	30	40	50	75	100	125	150
B	4	4	4	4	6	6	6	8	8
BA	50	50	50	60	35	60	70	75	80
C	2	2	2	2	3	4	5	6	7
CA	22	22	22	22	20	26	32	40	30
CB	45	45	45	55	35	35	35	38	40
DA	35	45	55	65	75	100	125	150	175
DB	/	/	/	/	/	/	162	218	258
EA	12	12	12	12	12	33	50	67	82
EB	47	47	47	57	70	90	114	155	180
FA	22	22	22	22	55	61	102	154	190
FB	45	45	45	55	35	70	70	76	80
G	40	40	40	50	35	60	70	75	80
L	92	92	92	102	115	156	197	255	295
LA	90,5	90,5	90,5	100,5	113,5	154,5	195,5	253,5	293,5
LB	108	108	108	118	131	172	213	271	311
Weight g	1660	1680	1690	1840	2090	2650	3270	4140	4710

**Mounting options**

**SIDE THREADED HOLES**



Bore	Screw	Torque (Nm)	Max. Length L (mm)
Ø8	M3	2,1	8
Ø12	M4	4,4	10
Ø16	M5	7,4	12
Ø20	M5	7,4	12
Ø25	M6	18	16

**SIDE THROUGH HOLES**

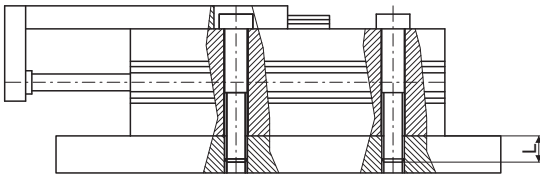

Bore	Screw	Torque (Nm)	Max. Length L (mm)
Ø8	M3	1,2	13
Ø12	M4	2,8	18,5
Ø16	M5	5,7	24
Ø20	M5	5,7	29
Ø25	M6	18	34

**AXIAL THREADED HOLES**

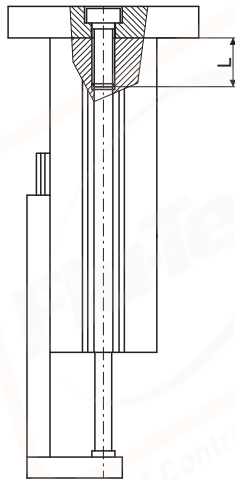

Bore	Screw	Torque (Nm)	Max. Length L (mm)
Ø8	M3	0,9	4
Ø12	M4	2,1	6
Ø16	M5	4,4	7
Ø20	M5	4,4	8
Ø25	M6	7,4	10

**Mounting load**

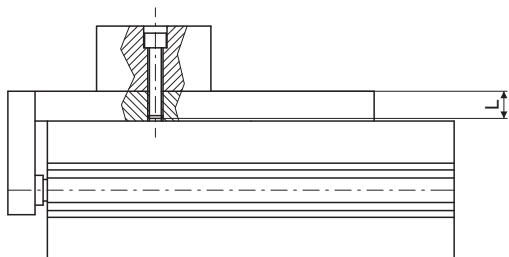

Bore	Screw	Torque (Nm)	Max. Length L (mm)
Ø8	M3	2,1	6
Ø12	M4	4,4	8
Ø16	M5	7,4	10
Ø20	M5	7,4	13
Ø25	M6	18	15

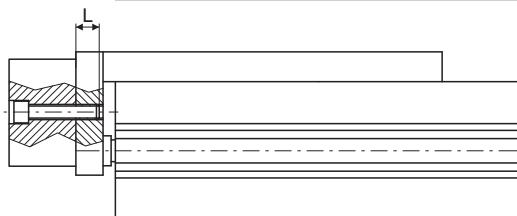

Bore	Screw	Torque (Nm)	Max. Length L (mm)
Ø8	M3	0,9	5
Ø12	M4	2,1	5,5
Ø16	M5	4,4	6
Ø20	M5	4,4	10
Ø25	M6	7,4	13

Kinetic energy (J)	Bore	With elastic bumper	With shock absorber
	Ø8	0,027	See Dampers 6900
	Ø12	0,055	
	Ø16	0,11	
	Ø20	0,16	
	Ø25	0,24	

### Plate deflection

With front moment under static conditions completely extended and with load applied as indicated by the arrows.

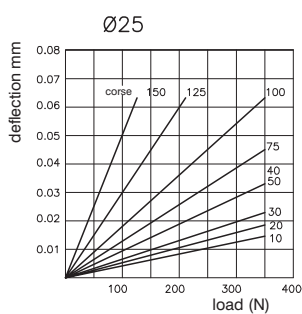
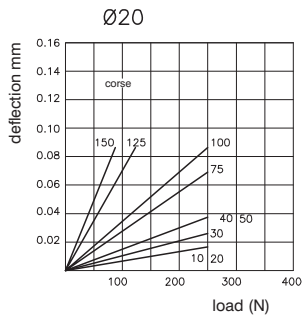
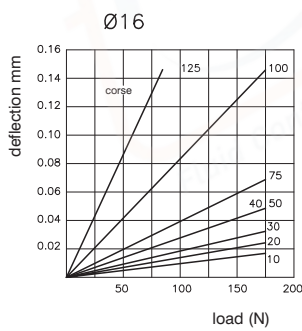
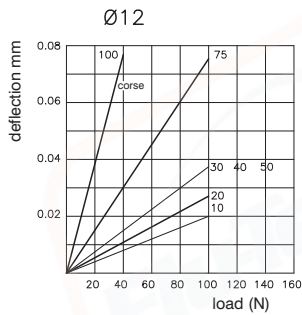
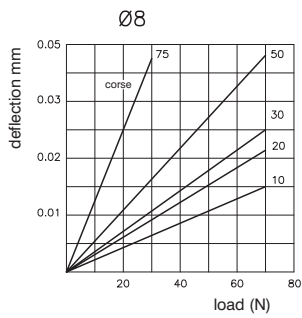

With side moment under static conditions completely extended and with load applied as indicated by the arrow

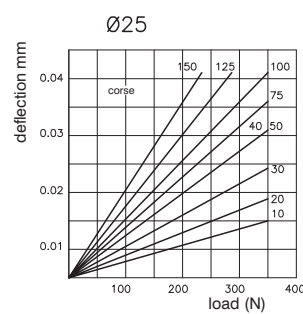
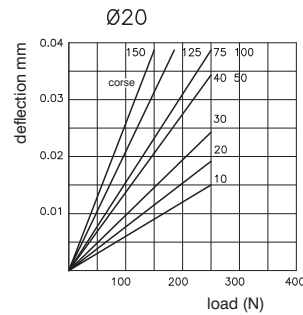
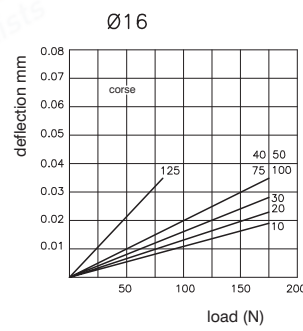
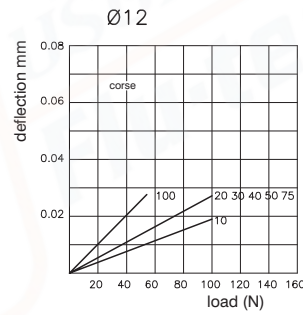
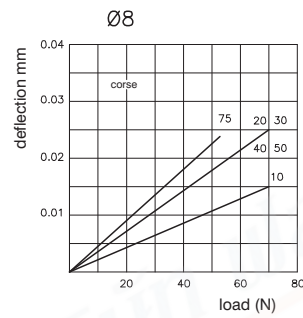
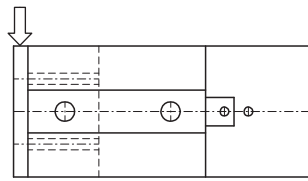

With misaligned side moment with load applied as indicated by the arrow at a distance "L" and with plate completely retracted.

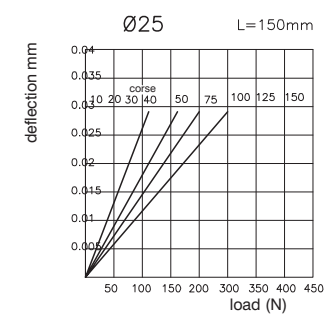
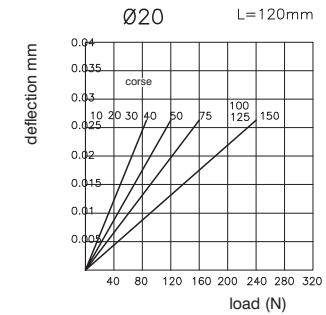
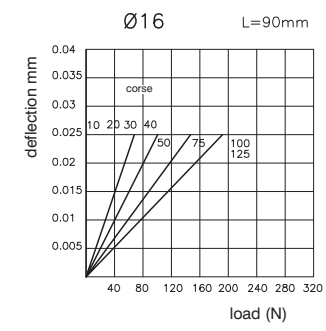
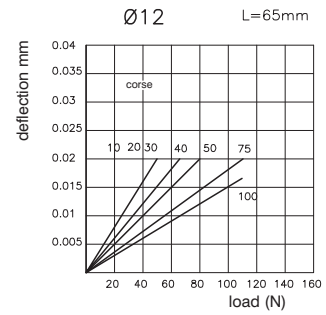
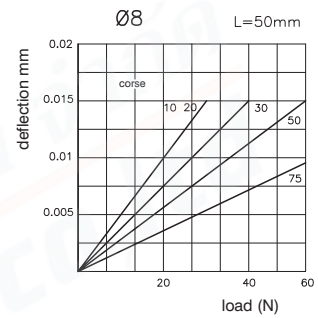
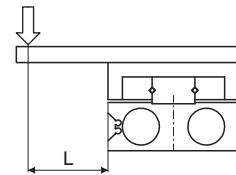



Accessories - Static moment  
Dimensions with dampers

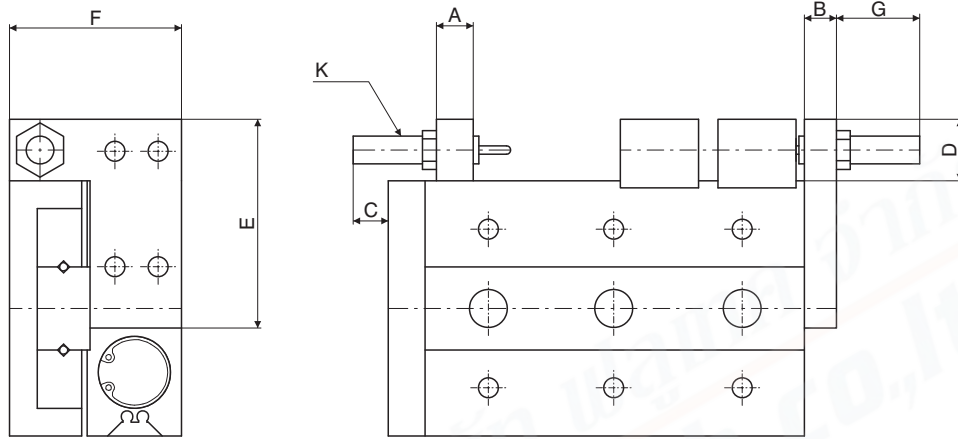

3

PNEUMATIC ACTUATION

Dimensions with adjusting screw

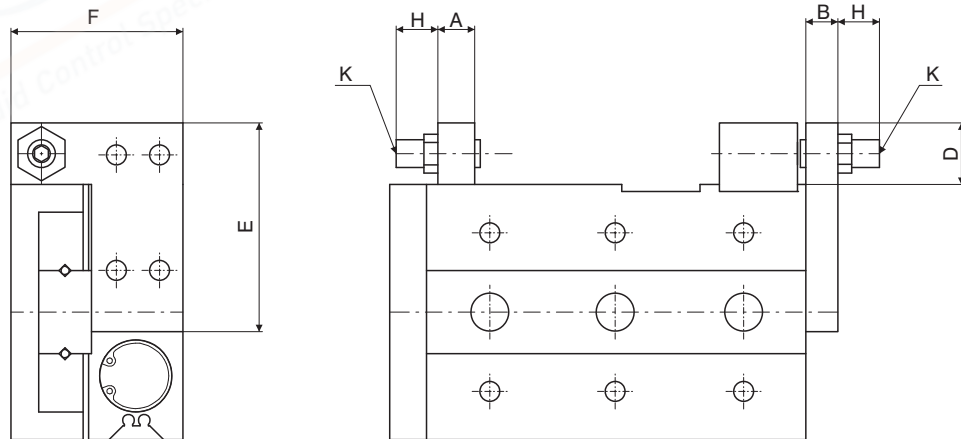

Bore	A	B	C	D	E	F	G max.	H max.	K
Ø8	7	8	26	14,5	38,5	23	25,5	28,5	M8x1
Ø12	9,5	8	21	15	45	31,5	24,5	32	M8x1
Ø16	11	10	19	18	55	37,5	29	34,5	M10x1
Ø20	13	12	28	24,5	70	47,5	42,5	35,5	M14x1,5
Ø25	16	15	34	24,5	80	54,5	39,5	37,5	M14x1,5

► Shock absorber mounting block / front stroke adjusting screw

Ordering code  
**6600.Ø.SU**

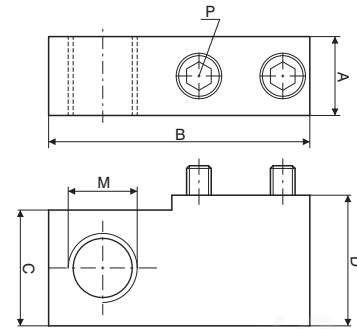

Bore	A	B	C	D	M	P
Ø8	7	23	14	15,5	M8x1	M3x16
Ø12	9,5	31	14,5	16		M4x16
Ø16	11	37	17,5	19	M10x1	M5x18
Ø20	13	45,5	23,5	26	M14x1,5	M6x25
Ø25	16	53,5		26,5		M8x25

► Reference block

Ordering code  
**6600.Ø.SI**

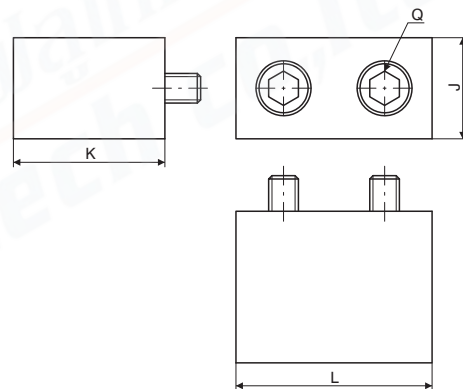
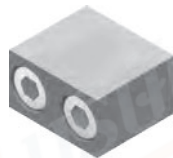

Bore	J	K	L	Q
Ø8	7	15,5	14,6	M3x16
Ø12	10	15	18,5	M4x14
Ø16	12	18,5	21	M5x18
Ø20	13	25,5	25	M6x25
Ø25	17		31	M8x25

► Shock absorber mounting block / rear stroke adjusting screw

Ordering code  
**6600.Ø.SR**

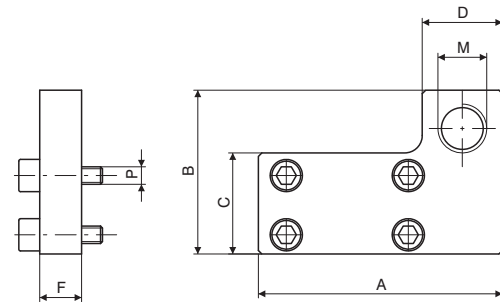

Bore	A	B	C	D	F	M	P
Ø8	38	23	12,5	14	8	M8x1	M3x12
Ø12	45	31	18				M4x12
Ø16	55	37	23,5	16	10	M10x1	M5x14
Ø20	70	47	29	23	12	M14x1,5	M5x16
Ø25	80	54	35		15		M6x20

► Adjusting screw

Ordering code  
**6600.Ø.VR**

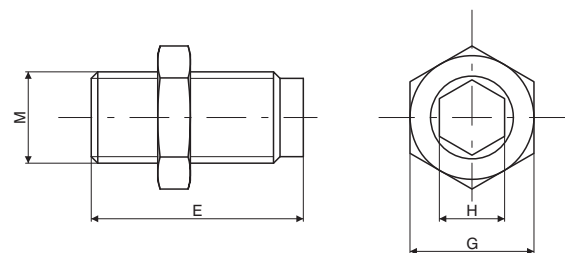

Bore	E	G	H	M
Ø8	36,5	12	4	M8x1
Ø12	40		4	
Ø16	44,5	14	5	M10x1
Ø20	47,5	22	8	M14x1,5
Ø25	52,5			