

Series 6100 - 6101 - 6110 - Guided compact cylinder

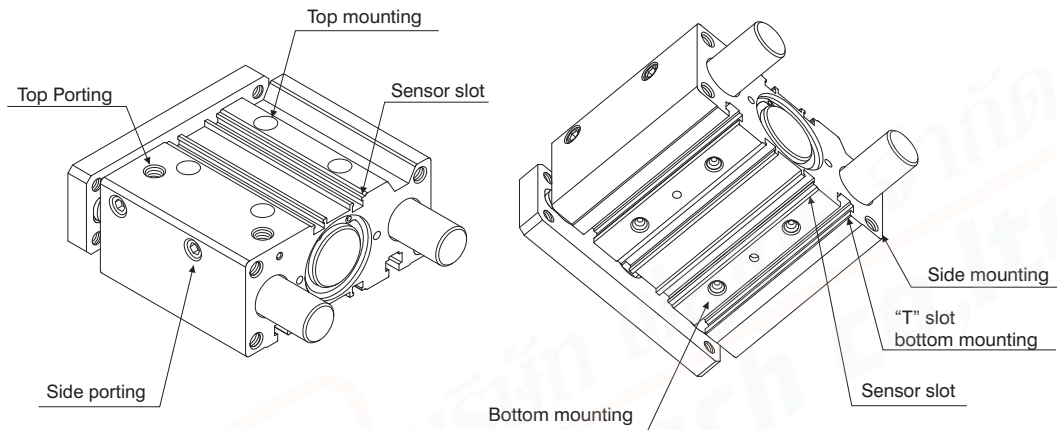

3

PNEUMATIC ACTUATION

These guided compact cylinders, characterised by reduced overall dimensions, can be used for the compression, conveyance and manipulation of objects in many industrial sectors; similarly they can also be used in pushing, lifting and stopping applications.

These cylinders are available in sizes 32mm to 63 mm diameter, and comprise a single compact cylinder with integral guide rods, making it a true guide cylinder designed with installation flexibility and space saving in mind.

The rod guide is available in two styles:

Self-lubricating bronze bushes - useful for absorbing lateral loads and forces, especially as a stopper.

Bearing bushes - guaranteeing high precision and uniform movement with low friction characteristics, useful with mis-aligned loads.

Guided compact cylinders are ideal for use in applications requiring a combination of reduced dimensions and anti-rotation features. Mounting can be achieved on three sides through holes or “T” slots.

Adjustable mounting holes in the front plate ensure safe and accurate assembly. Pneumatic connections can be made to either lateral or top ports (lateral ports plugged on standard units).

When sensors are required, there are special slots in the barrel extrusion where 1580 series miniaturised sensors are easily fitted.

► Guided compact cylinder



Ordering code

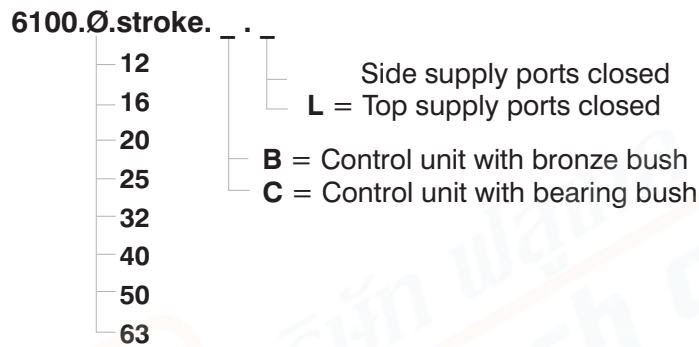

Construction characteristics

Body	anodised aluminium
Guide rods	C43 chromed steel (control unit with bronze bush) tempered and chromed steel (control unit with bearing bush)
Piston	aluminium
Piston rod	stainless steel (for bores Ø12, Ø16, Ø20, Ø25) C43 chromed steel (for bores Ø32, Ø40, Ø50, Ø63)
Rods bushing	bronze or bearing bushing
End cap	anodised aluminium
Piston seal	oil resistant NBR rubber
Piston rod seal	PUR (NBR 12-16)
Wipers	PUR
Plate	nickel plated steel

Operational characteristics

Function	double acting
Fluid	Filtered air. No lubrication needed, if applied it shall be continuous.
Working pressure	max. 10 bar
Working temperature	-5°C - +70°C
Cushioning	elastic bumper on both ends

Standard stroke

Bore	Stroke											
	10	20	25	30	40	50	75	100	125	150	175	200
Ø12	●	●		●	●	●	●	●				
Ø16	●	●		●	●	●	●	●				
Ø20		●		●	●	●	●	●	●	●	●	●
Ø25		●		●	●	●	●	●	●	●	●	●
Ø32			●			●	●	●	●	●	●	●
Ø40			●			●	●	●	●	●	●	●
Ø50			●			●	●	●	●	●	●	●
Ø63			●			●	●	●	●	●	●	●

Intermediate strokes can be obtained using spacers with defined length (5, 10, 15, 20 mm).

Example: It is possible to obtain a 6100.32.45.B cylinder from a 6100.32.50.B cylinder by inserting a spacer with length of 5 mm. The intermediate strokes manufactured without the use of spacers are considered special executions.

Overall dimensions

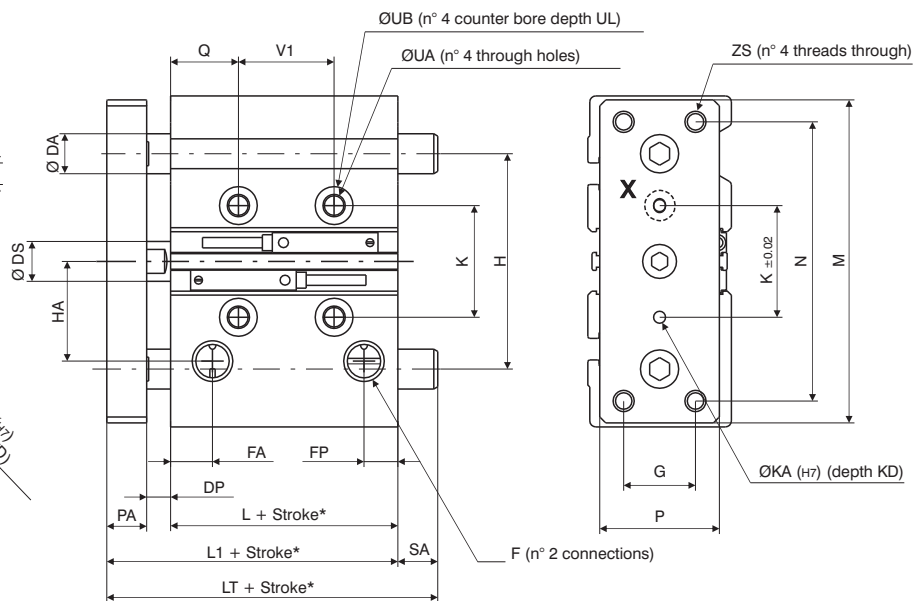
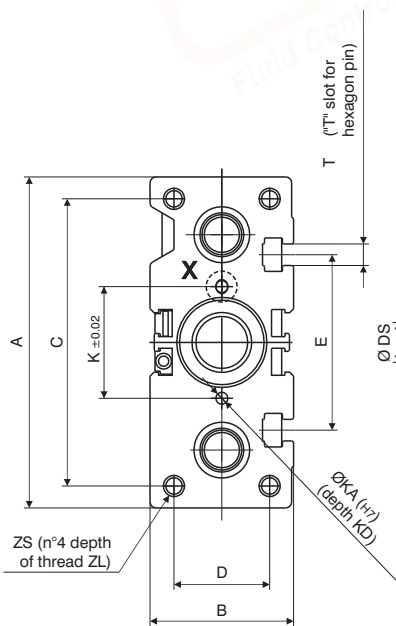
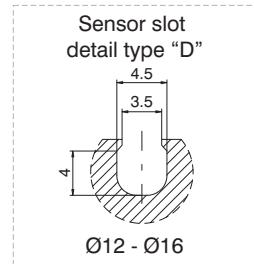
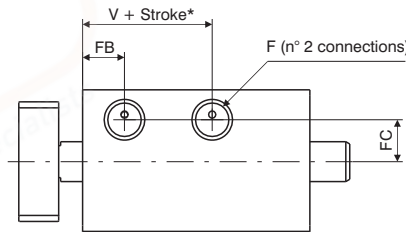
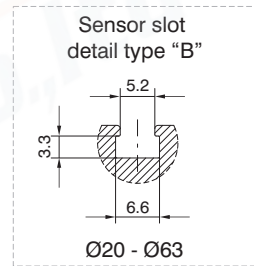
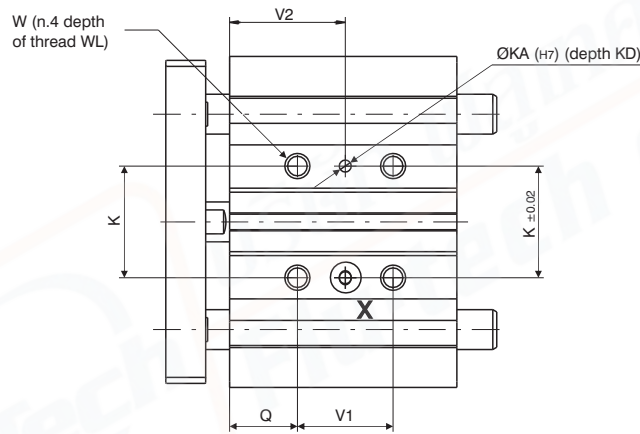
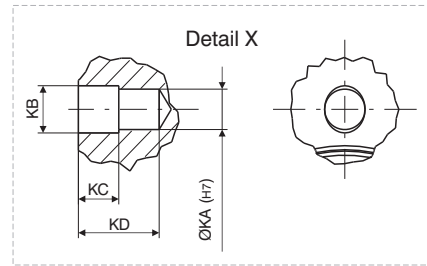
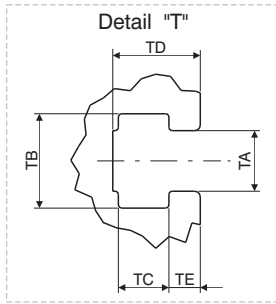

*Dimensions only refer to the "standard stroke"

3 PNEUMATIC ACTUATION



Overall dimensions

Bore		Ø12	Ø16	Ø20	Ø25	Ø32	Ø40	Ø50	Ø63
Table of dimensions									
A		58	64	83	93	112	120	148	162
B		26	30	36	42	48	54	64	78
C		40	42	72	82	98	106	130	142
D		18	22	24	30	34	40	46	58
Control unit with bronze bushes	DA	8	10	12	16	20	20	25	25
	Control unit with bearing bushes	6	8	10	14	16	16	20	20
DP		2	2	5,5	5,5	9,5	10	13	13
DS		6	8	10	12	16	16	20	20
E		/	/	44	50	63	72	92	110
F		M5	M5	G1/8"	G1/8"	G1/8"	G1/8"	G1/4"	G1/4"
FA		11	11	11	12	13	13	13	14
FB		11	11	11	12	13	13	13	14
FC		8,5	10	10,5	13,5	15	18	21,5	28
FP		15	17	9	10,5	9,5	11	11	12,5
G		14	16	18	26	30	30	40	50
H		41,5	46	54	64	78	86	110	124
HA		19,5	23	25	28,5	34	38	47	55
K		23	24	28	34	42	50	66	80
KA		/	/	3	4	4	4	5	5
KB		/	/	3,5	4,5	4,5	4,5	6	6
KC		/	/	3	3	3	3	4	4
KD		/	/	6	6	6	6	8	8
L		29	31	38	38,5	38,5	44	44	49
Control unit with bronze bushes	L1	39	43	53,5	54	60	66	72	77
	Control unit with bearing bushes	39	43	53,5	54	97	97	106,5	106,5
Control unit with bearing bushes	LT	57	64	84,5	85	102	102	118	118
	See table 1								
M		56	62	81	91	110	118	146	158
N		48	52	70	78	96	104	130	130
PA		8	10	10	10	12	12	15	15
P		22	25	30	38	44	44	60	70
Q		5	5	17,5	17,5	21,5	22	24	24
Control unit with bronze bushes	SA	/	/	/	/	37	31	34,5	29,5
	Control unit with bearing bushes	18	21	31	31	42	36	46	41
See table 1									
T		/	/	M5	M5	M6	M6	M8	M10
TA		/	/	5,4	5,4	6,5	6,5	8,5	11
TB		/	/	8,4	8,4	10,5	10,5	13,5	17,8
TC		/	/	4,5	4,5	5,5	5,5	7,5	10
TD		/	/	7,8	8,2	9,5	11	13,5	18,5
TE		/	/	2,8	3	3,5	4	4,5	7
UA		4,3	4,3	5,6	5,6	6,6	6,6	8,6	8,6
UB		8	8	9,5	9,5	11	11	14	14
UL		4,5	4,5	5,5	5,5	7,5	7,5	9	9
V		14	14	13	13	7,5	13	9	14
V1		See table 2							
V2		See table 2							
W		M5	M5	M6x1	M6x1	M8x1,25	M8x1,25	M10x1,5	M10x1,5
WL		10	10	12	12	16	16	20	20
Z		M4	M5	M5x0,8	M6x1	M8x1,25	M8x1,25	M10x1,5	M10x1,5
ZL		9	11	13	15	20	20	22	22

Control unit with bearing bushes	Table 1	LT			SA		
	Bore	stroke ≤ 30	30 < stroke ≤ 100	100 < stroke ≤ 200	stroke ≤ 30	30 < stroke ≤ 100	100 < stroke ≤ 200
	Ø12	39	53	53	/	14	/
	Ø16	43	64	64	/	21	/
	Ø20	47	72	72	/	18,5	49
	Ø25	49	77	77	/	23	48
		stroke < 50	50 ≤ stroke ≤ 100	100 < stroke ≤ 200	stroke < 50	50 ≤ stroke ≤ 100	100 < stroke ≤ 200
	Ø32	/	87	117	/	27	57
	Ø40	/			/	21	51
	Ø50	/	92	127	/	20	55
	Ø63	/			/	15	50

Control unit with bearing bushes	Table 2	V1			V2		
	Bore	stroke ≤ 30	30 < stroke ≤ 100	100 < stroke ≤ 200	stroke ≤ 30	30 < stroke ≤ 100	100 < stroke ≤ 200
	Ø12	4 + stroke			/	/	/
	Ø16				/	/	/
	Ø20	24	44	120	29,5	39,5	77,5
	Ø25	stroke ≤ 25			stroke ≤ 25		
	Ø32						
	Ø40	24	48	124	34	46	84
	Ø50	stroke ≤ 25			36	48	86
	Ø63				28	52	128



Weight - Cylinder force - kinetic energy

Stroke	Bore								Weight g							
	Ø12	Ø16	Ø20	Ø25	Ø32	Ø40	Ø50	Ø63								
Stroke	Control unit with bronze bushes								Weight g							
10	240	330	/	/	/	/	/	/	/							
20	280	380	670	950	/	/	/	/	/							
25	/	/	/	/	1690	1950	3360	4180	/							
30	310	430	750	1050	/	/	/	/	/							
40	350	480	830	1160	/	/	/	/	/							
50	390	530	910	1270	2070	2370	4000	4940	/							
75	500	680	1170	1650	2470	2830	4730	5780	/							
100	5903	800	1370	1920	2850	3250	5370	6540	/							
125	/	/	1570	2190	3240	3680	6010	7290	/							
150	/	/	1760	2470	3620	4100	6650	8050	/							
175	/	/	1960	2740	4000	4530	7290	8800	/							
200	/	/	2160	3010	4380	4950	7930	9560	/							
Stroke	Moving parts															
10	100	155	/	/	/	/	/	/	/							
20	108	170	330	520	/	/	/	/	/							
25	/	/	/	/	1070	1140	2150	2500	/							
30	116	185	350	560	/	/	/	/	/							
40	124	200	380	600	/	/	/	/	/							
50	132	215	400	640	1230	1300	2400	2750	/							
75	152	250	520	840	1420	1490	2750	3090	/							
100	172	285	580	950	1580	1650	3000	3350	/							
125	/	/	640	1050	1740	1810	3260	3600	/							
150	/	/	700	1150	1910	1980	3510	3860	/							
175	/	/	760	1250	2070	2140	3760	4110	/							
200	/	/	820	1350	2230	2300	4020	4360	/							
Stroke	Control unit with bearing bushes															
10	240	340	/	/	/	/	/	/	/							
20	270	390	700	980	/	/	/	/	/							
25	/	/	/	/	1540	1790	3110	3930	/							
30	300	430	770	1070	/	/	/	/	/							
40	350	510	890	1250	/	/	/	/	/							
50	390	560	970	1340	1850	2150	3660	4590	/							
75	470	670	1140	1570	2300	2640	4410	5460	/							
100	560	790	1310	1810	2620	3000	4960	6120	/							
125	/	/	1520	2080	2990	3420	5600	6880	/							
150	/	/	1690	2310	3310	3780	6150	7540	/							
175	/	/	1870	2540	3620	4140	6700	8210	/							
200	/	/	2040	2770	3940	4500	7250	8870	/							
Stroke	Moving parts															
10	95	145	/	/	/	/	/	/	/							
20	100	153	310	490	/	/	/	/	/							
25	/	/	/	/	820	890	1770	2110	/							
30	105	161	330	520	/	/	/	/	/							
40	110	169	370	580	/	/	/	/	/							
50	120	177	390	610	940	1010	1950	2300	/							
75	145	197	440	690	1110	1180	2240	2590	/							
100	170	217	480	760	1230	1300	2430	2770	/							
125	/	/	560	880	1410	1480	2710	3050	/							
150	/	/	600	950	1530	1600	2890	3240	/							
175	/	/	650	1020	1650	1720	3080	3420	/							
200	/	/	700	1100	1770	1830	3270	3610	/							
Working pressure	Cylinder theoretic force (N)															
2 bar	23	17	40	30	63	47	98	76	161	121	251	211	393	330	623	561
3 bar	34	26	60	45	94	71	147	113	241	181	377	317	589	495	935	841
4 bar	45	34	80	60	126	94	196	151	322	241	503	422	785	660	1247	1121
5 bar	57	43	101	76	157	118	246	189	402	302	629	528	982	825	1559	1402
6 bar	68	51	121	91	188	142	295	227	482	362	754	634	1178	989	1870	1682
7 bar	79	60	141	106	220	165	344	265	563	422	880	739	1374	1154	2182	1962
8 bar	90	68	161	121	251	189	393	302	643	482	1006	845	1570	1319	2494	2242
9 bar	102	77	181	136	283	212	442	340	724	543	1131	950	1767	1484	2805	2523
10 bar	113	85	201	151	314	236	491	378	804	603	1257	1056	1963	1649	3117	2803
Piston area (mm ²)	out	in	out	in	out	in	out	in	out	in	out	in	out	in	out	in
	113	85	201	151	314	236	491	378	804	603	1257	1056	1963	1649	3117	2803
	Maximum permissible Momentum															
J	0,08		0,09		0,11		0,18		0,29		0,52		0,91		1,54	

How to calculate the Momentum: $E_c = \frac{1}{2} m V^2$ (J)

m = Total moving mass: weight of driven object added to weight of cylinder moving parts (kg)

V = max. speed: equal to average speed + 40% (m/sec)

Operating criteria

Permissible lateral load (applied on overall plate)

Version	Stroke	Bore							
		Ø12	Ø16	Ø20	Ø25	Ø32	Ø40	Ø50	Ø63
		Permissible lateral load (N)*							
Control unit with bronze bushes	10	30	48						
	20	23	37	49	69				
	25					203	203	296	296
	30	19	30	43	60				
	40	16	25	38	54				
	50	14	20	35	49	164	164	245	245
	75	12	18	87	116	182	182	273	273
	100	10	15	75	100	159	159	241	241
	125			66	88	142	142	216	216
	150			59	79	127	127	195	195
	175			54	71	116	116	179	179
	200			49	65	106	106	164	164
	Control unit with bearing bushes	10	20	35					
20		15	28	58	69				
25						191	190	208	206
30		13	22	48	68				
40		11	18	101	132				
50		10	16	90	118	157	157	173	171
75		8	14	70	93	164	163	223	221
100		6	11	58	77	144	144	199	196
125				62	80	203	203	264	262
150				54	70	186	185	242	240
175				48	62	171	171	224	221
200				43	55	158	158	207	205
		Recommended torque moments (Nm)							
Control unit with bronze bushes	10	0,40	0,70						
	20	0,35	0,65	1,1	1,8				
	25					6,4	7,0	13,0	14,7
	30	0,28	0,48	0,9	1,6				
	40	0,25	0,45	0,8	1,4				
	50	0,21	0,39	0,8	1,3	5,1	5,7	10,8	12,1
	75	0,42	0,68	1,9	3,0	5,7	6,3	12,0	13,5
	100	0,40	0,60	1,6	2,6	5,0	5,5	10,6	11,9
	125			1,4	2,3	4,4	4,9	9,5	10,7
	150			1,3	2,0	4,0	4,4	8,6	9,7
	175			1,2	1,8	3,6	4,0	7,9	8,9
	200			1,1	1,7	3,3	3,7	7,2	8,2
	Control unit with bearing bushes	10	0,62	0,70					
20		0,41	0,65	1,3	2,1				
25						6,0	6,6	9,2	10,2
30		0,33	0,48	1,0	1,8				
40		0,30	0,45	2,2	3,4				
50		0,48	0,39	1,9	3,0	4,9	5,4	7,6	8,5
75		0,38	0,68	1,5	2,4	5,1	5,6	9,8	11,0
100		0,32	0,60	1,3	2,0	4,5	5,0	8,7	9,7
125				1,3	2,1	6,3	7,0	11,6	13,0
150				1,2	1,8	5,8	6,4	10,7	11,9
175				1,0	1,6	5,3	5,9	9,8	11,0
200				0,9	1,4	4,9	5,4	9,1	10,2

*(Applied on overall plate)

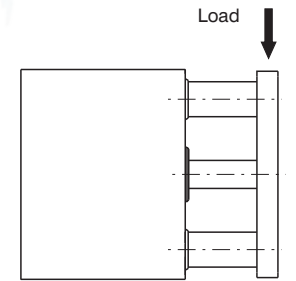
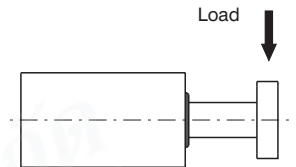

3
PNEUMATIC ACTUATION

Operating criteria

Stopper device applications

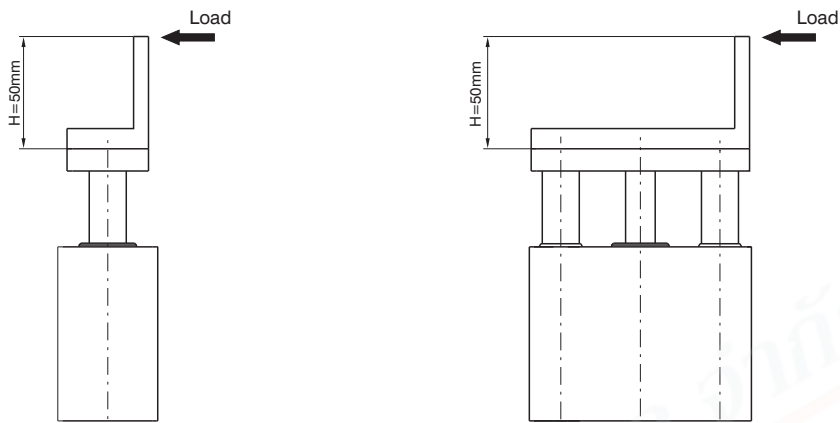

Control unit with
bronze bushes

ATTENTION: if H>50 mm use larger bore

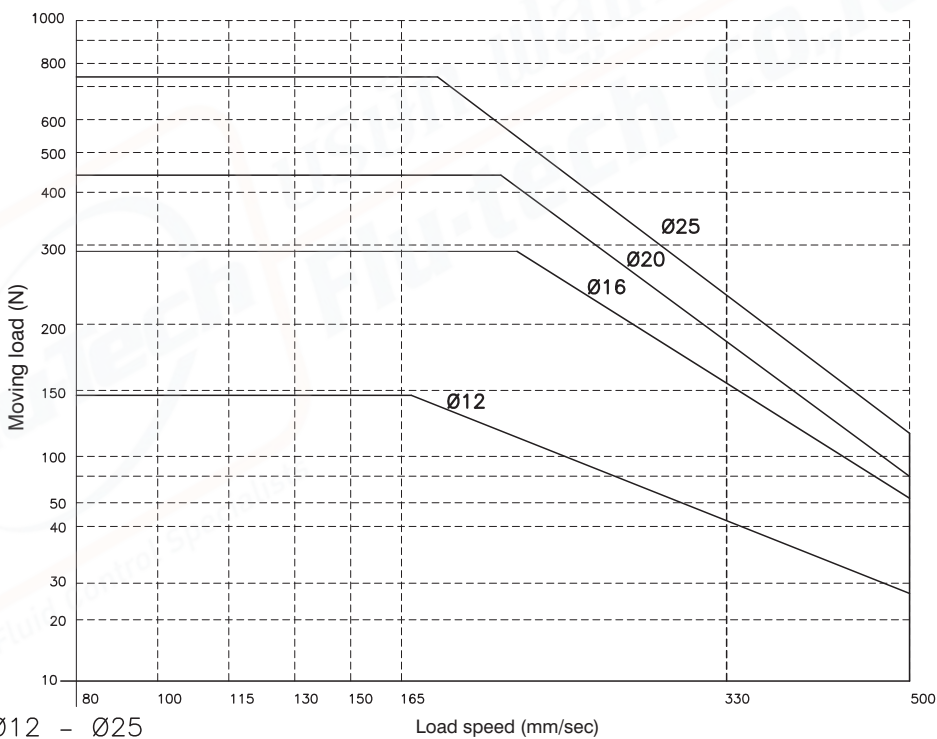

Ø12 - Ø25

ATTENTION: use with stroke £ 30 mm

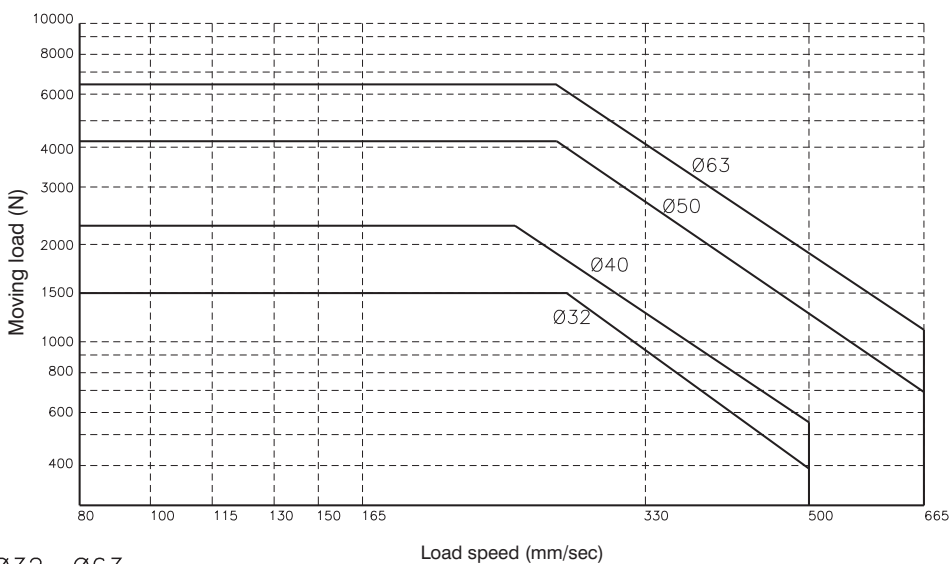

Ø32 - Ø63

ATTENTION: use with stroke £ 50 mm

Operating criteria
Handling applications

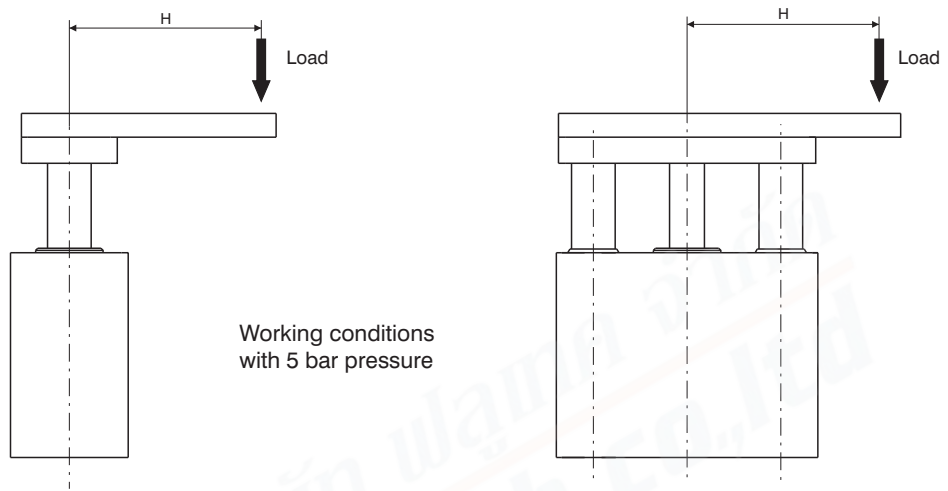

Control unit with bronze bushes

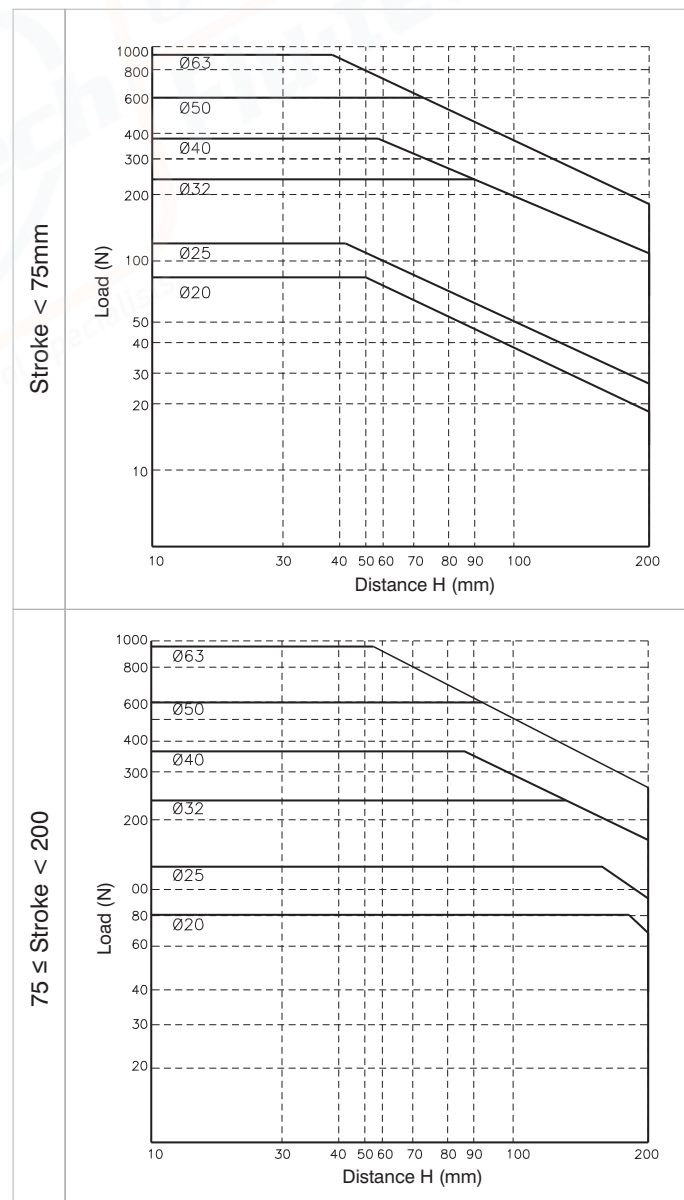

Operating criteria

Handling applications

Control unit with bearing bushes

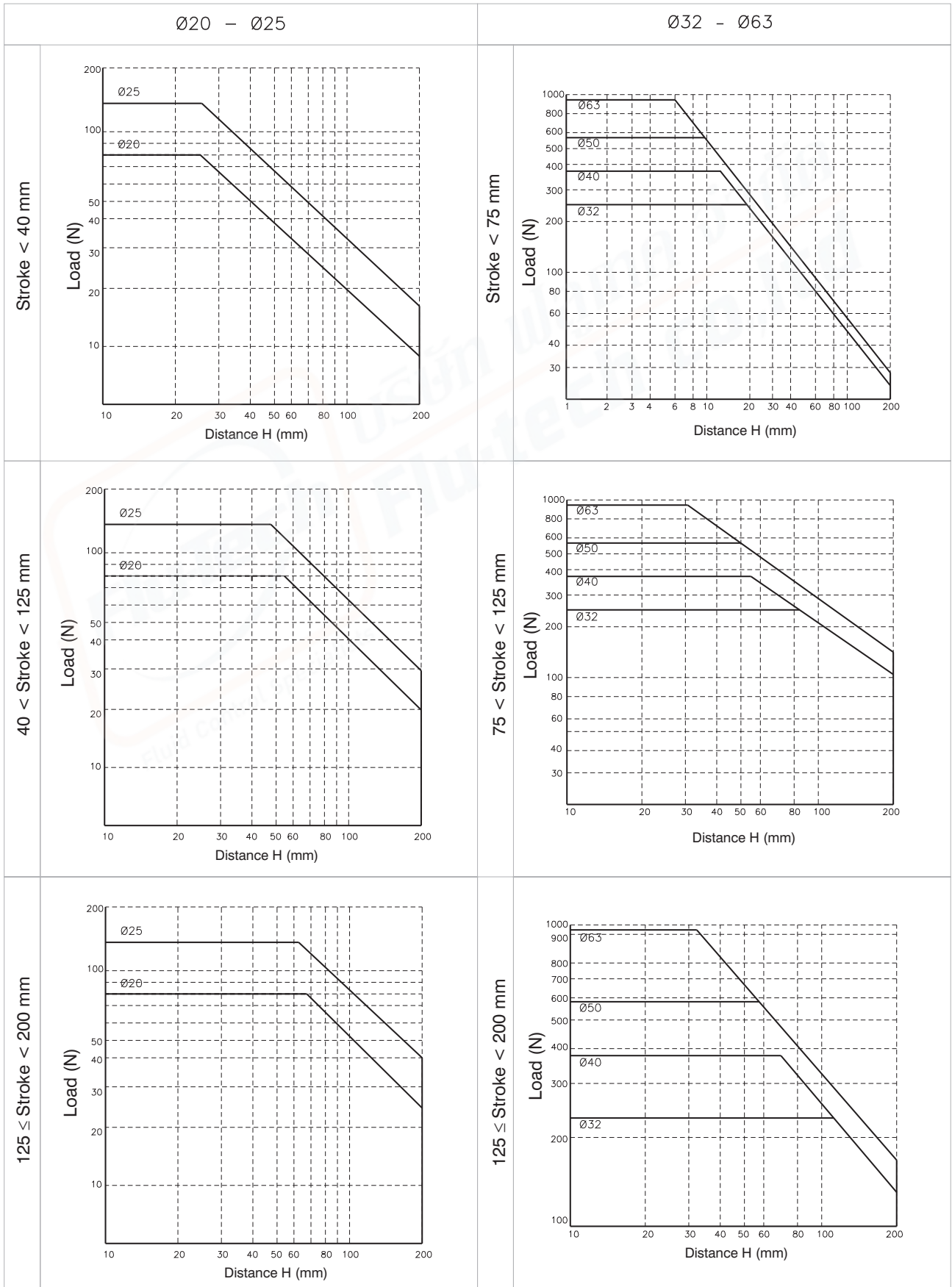

► Heavy duty guided short stroke cylinder

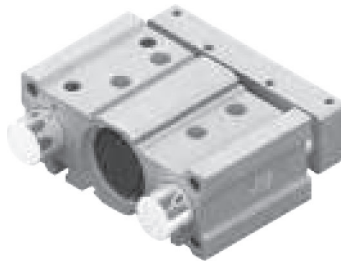

Ordering code

6101.80.stroke. B .

Side supply ports closed
L = Top supply ports closed

Construction characteristics

Body	anodised aluminium
Rods	C43 chromed steel
Piston	aluminium
Piston rod	C43 chromed steel
Piston rod bushing	sintered bronze
Rod bushing	teflon coated bush
End cap	aluminium
Piston seal	NBR oil-resistant rubber
Piston rod seal	PUR
Plate	anodised aluminium

Operational characteristics

Function	double acting
Fluid	Filtered air. No lubrication needed, if applied it shall be continuous.
Max. pressure	max. 10 bar
Working temperature	-5°C - +70°C
Cushioning	elastic bumper on both ends

Standard strokes

Bore	Stroke							
	25	50	75	100	125	150	175	200
Ø80	●	●	●	●	●	●	●	●

Intermediate strokes can be obtained by adding specific spacers (5, 10, 15, 20mm).

Example: It is possible to obtain a **6101.80.45.B** cylinder from a **6101.80.50.B** cylinder by adding a 5mm spacer.
The Intermediate strokes manufactured without the use of spacers are considered special executions.

Overall dimensions

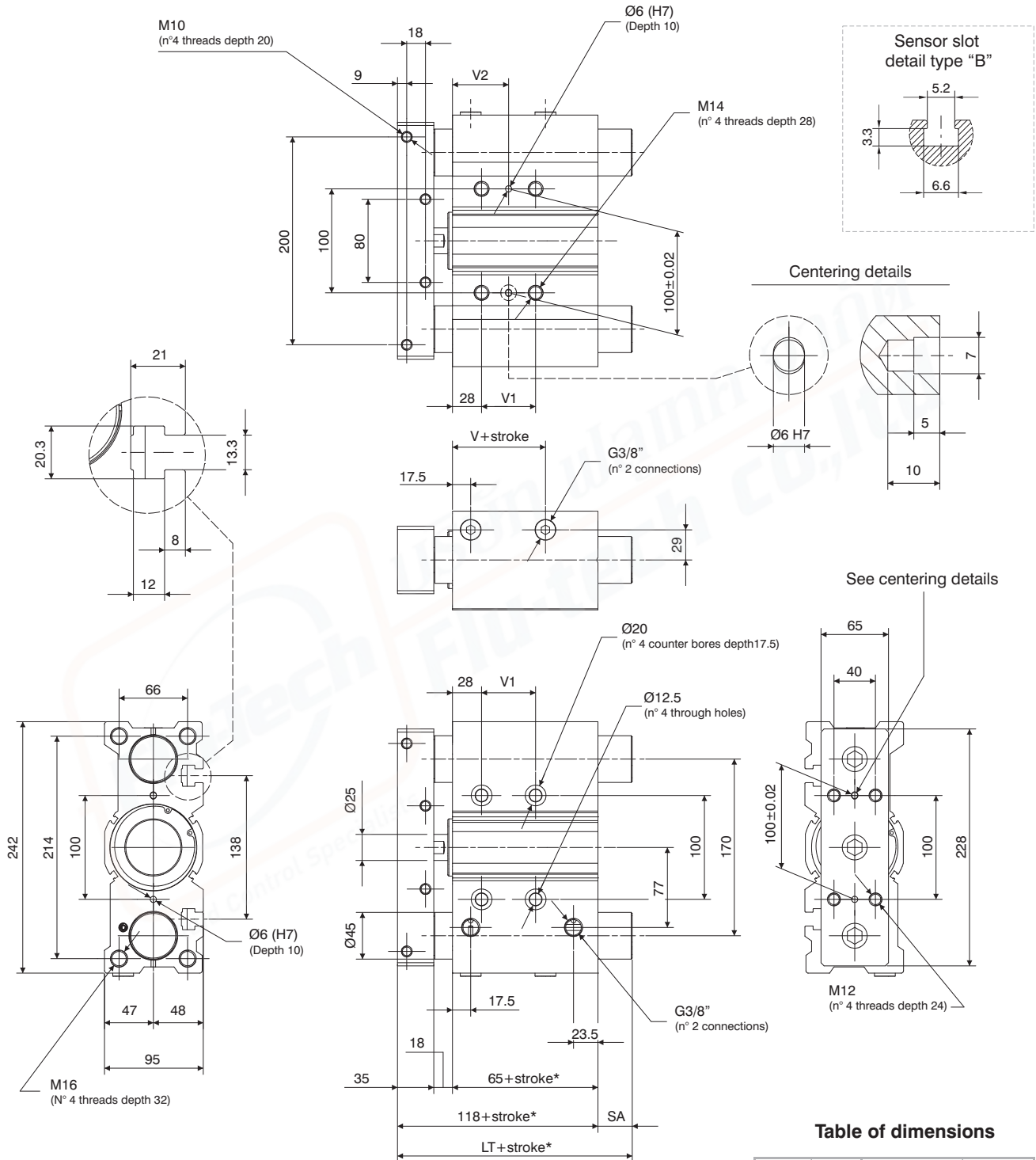

*Dimensions only refer to the "standard stroke"

Table of dimensions

stroke	25	LT	118
	50		118
	> 50		151
		V	14.5
	25	V1	28
	50		52
stroke	75		52
	100		52
	>100		128
	25	V2	42
	50		54
stroke	75		54
	100		54
	>100		92
	25	SA	0
stroke	50		
	> 50		33

PNEUMATIC ACTUATION

Operating criteria

Cylinder theoretic force (N)

Working pressure		
2 bar	1005	907
3 bar	1508	1361
4 bar	2011	1814
5 bar	2513	2268
6 bar	3016	2721
7 bar	3519	3175
8 bar	4021	3629
9 bar	4524	4082
10 bar	5027	4536
Effective area (mm ²)	out	in
	5027	4536

Recommended torque moments

Stroke	N/m
25	49
50	41
75	51
100	45
125	41
150	38
175	35
200	32



“Stopper” device applications

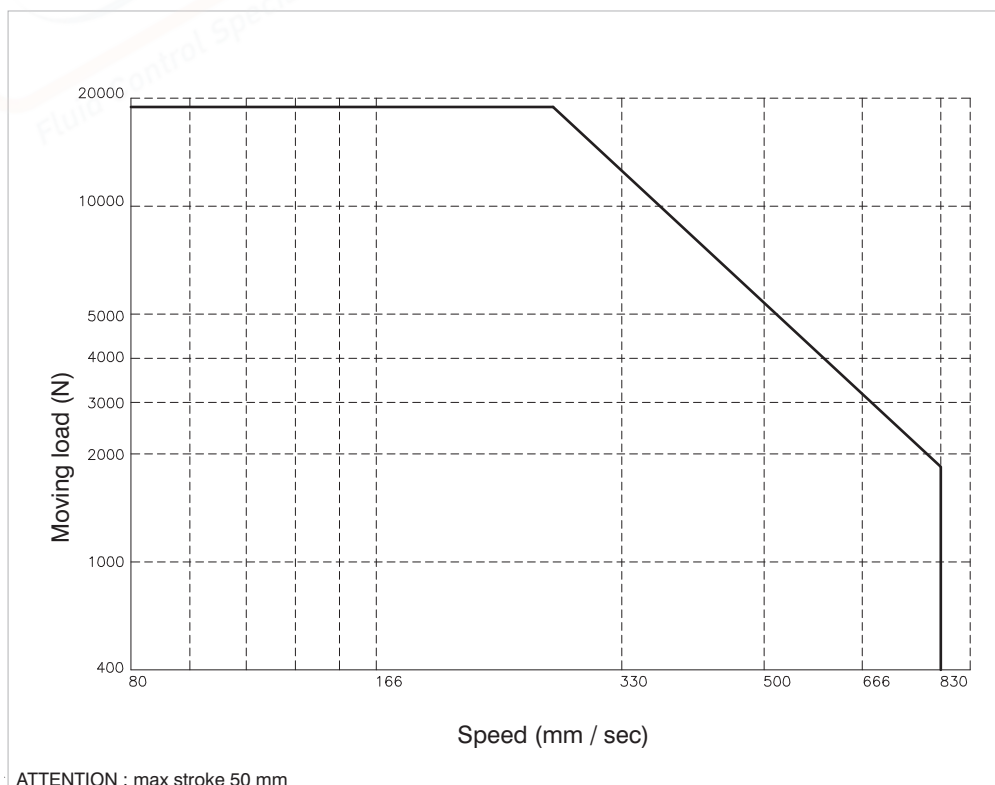
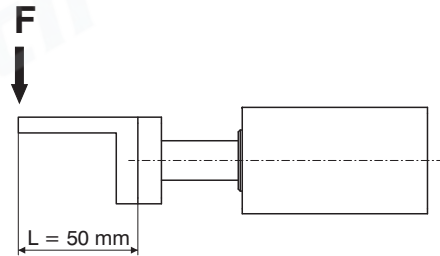
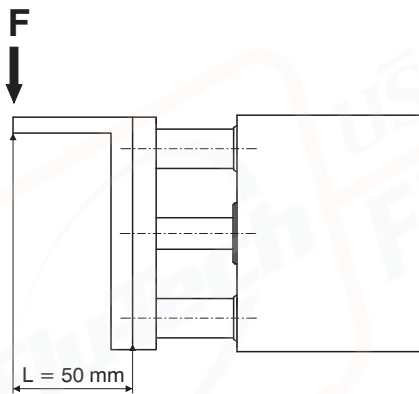

Operating criteria

Handling applications

VERTICAL assembly position

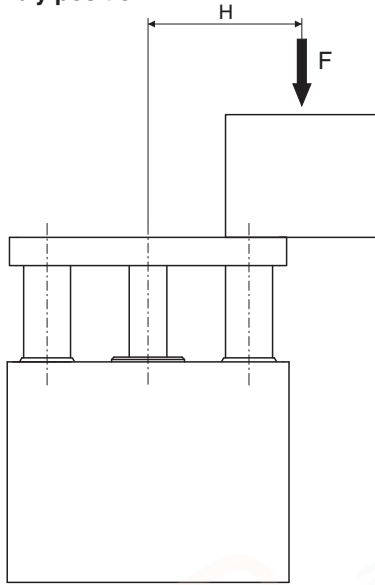

HORIZONTAL assembly position

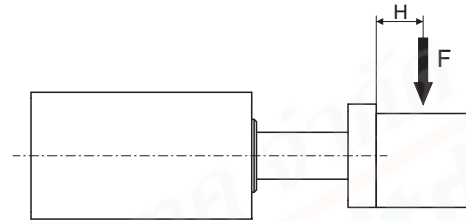

PNEUMATIC ACTUATION

STROKE ≤ 50 mm / V = 200 mm/s

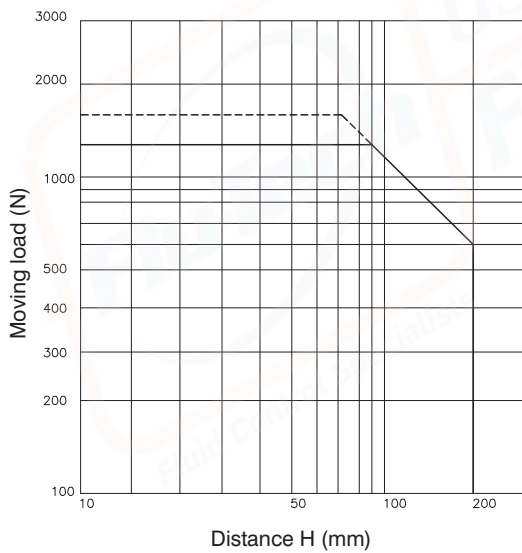

H = 50 mm / V = 200 mm/s

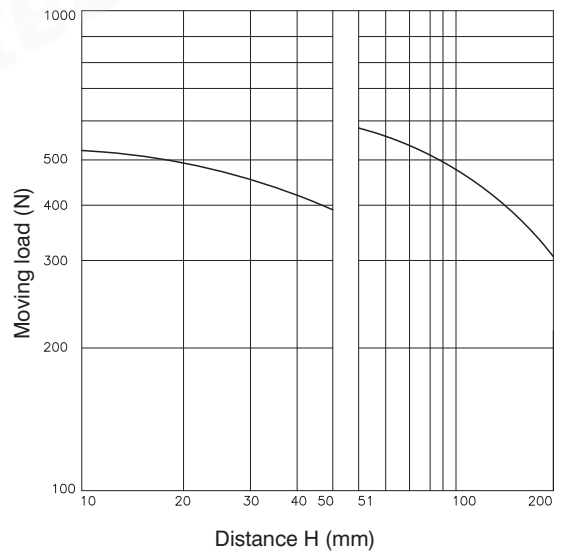

STROKE > 50 mm / V = 200 mm/s

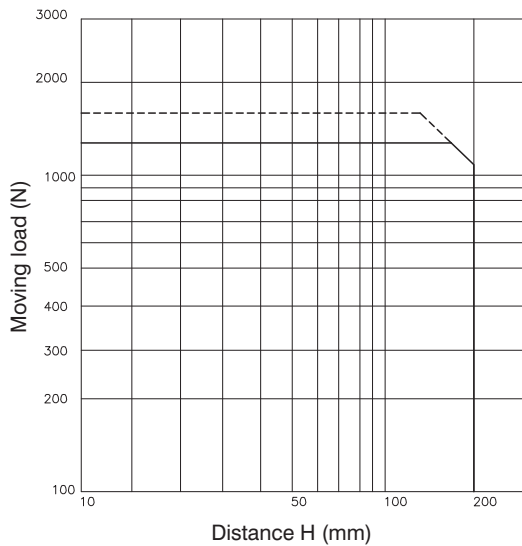

H = 100 mm / V = 200 mm/s

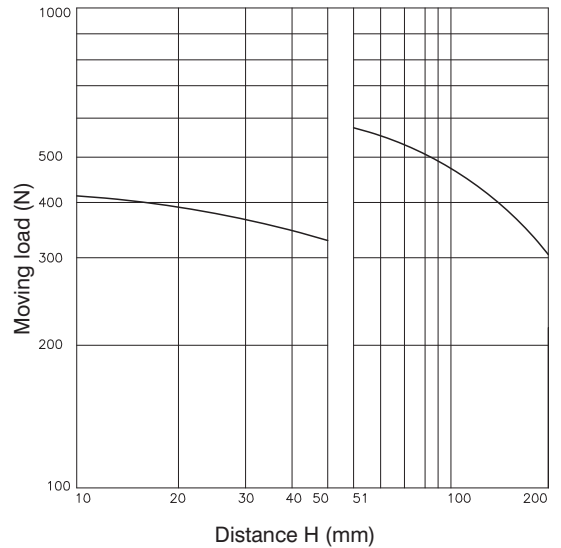

———— Working pressure : 4 bar
- - - - - Working pressure : 5 bar

► Guided compact cylinder with additional metal rod scrapers



Ordering code

6110.Ø.stroke. C .

- 32
- 40
- 50
- 63

Side supply ports closed
L = Top supply ports closed

Construction characteristics

Body	anodised aluminium
Guide rods	tempered and chromed steel
Piston	aluminium
Piston rod	C43 chromed steel
Rods bushing	bearing bushing
End cap	anodised aluminium
Piston seal	oil resistant NBR rubber
Piston rod seal	PUR
External rod scraper	brass
Internal rod scraper	NBR
Plate	nickel plated steel

The cylinders are equipped with 4 rod scrapers on the guide rods and 1 rod scraper on the central piston rod

Operational characteristics

Function	double acting
Fluid	Filtered air. No lubrication needed, if applied it shall be continuous.
Working pressure	max. 10 bar
Working temperature	-5°C - +70°C
Cushioning	elastic bumper on both ends

Standard strokes

Bore	Stroke									
	10	20	25	50	75	100	125	150	175	200
Ø32			●	●	●	●	●	●	●	●
Ø40			●	●	●	●	●	●	●	●
Ø50			●	●	●	●	●	●	●	●
Ø63			●	●	●	●	●	●	●	●

Intermediate strokes can be obtained using spacers with defined length (5, 10, 15, 20 mm).

Example: It is possible to obtain a **6110.32.45.B** cylinder from a **6110.32.50.B** cylinder by inserting a spacer with length of 5 mm. The intermediate strokes manufactured without the use of spacers are considered special executions.

Overall dimensions

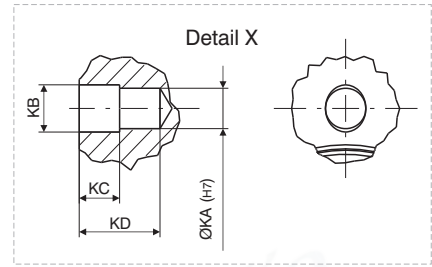
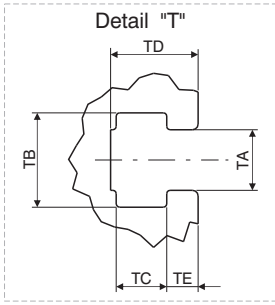

3

PNEUMATIC ACTUATION

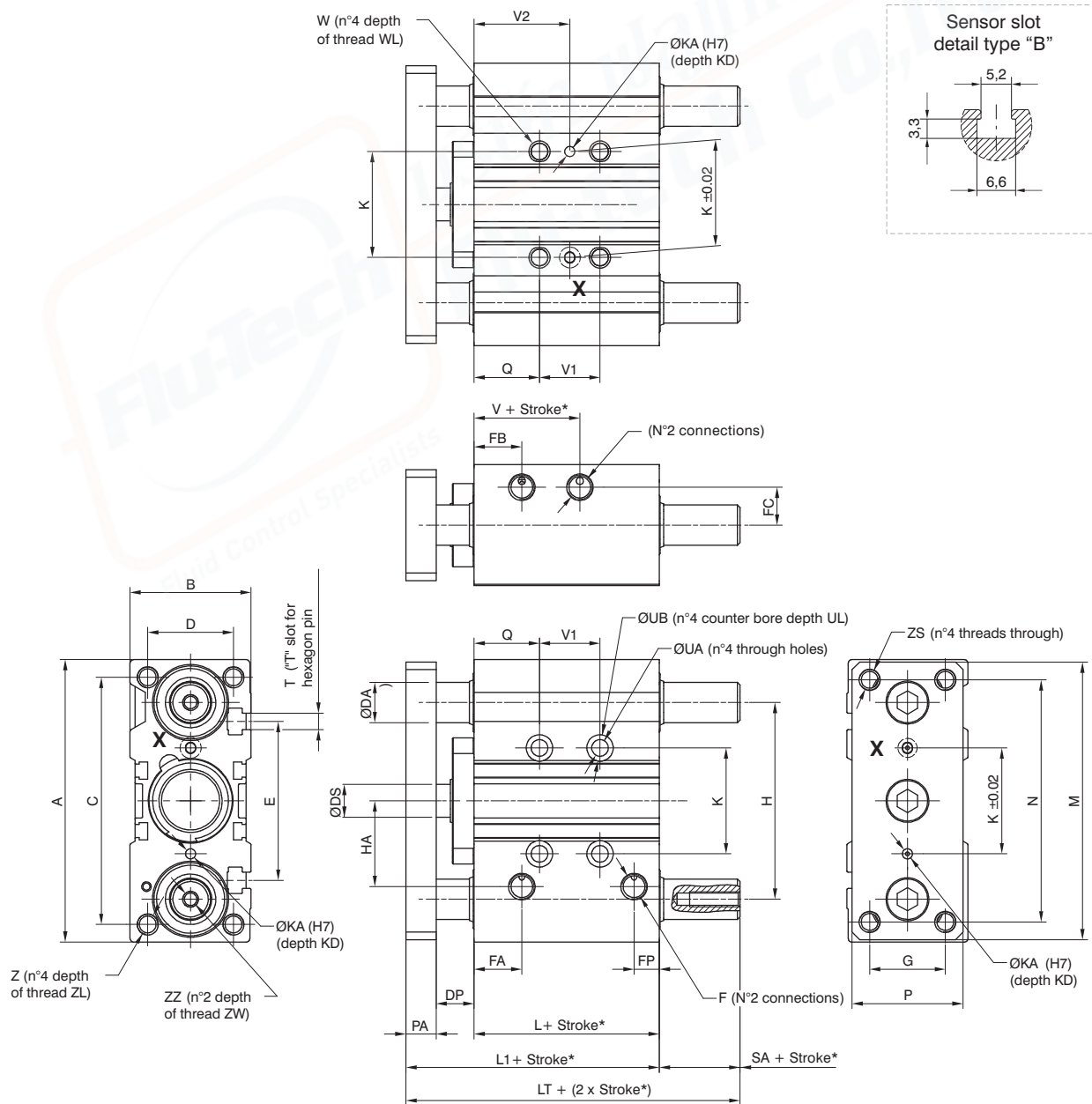

Overall dimensions

Bore	Ø32	Ø40	Ø50	Ø63
Table of dimensions				
A	112	120	148	162
B	48	54	64	78
C	98	106	130	142
D	34	40	46	58
DA	16	16	20	20
DP	15	20	23	23
DS	16	16	20	20
E	63	72	92	110
F	G1/8"	G1/8"	G1/4"	G1/4"
FA	19	13	13	14
FB	19	13	13	14
FC	15	18	21,5	28
FP	10	11	11	12,5
G	30	30	40	50
H	78	86	110	124
HA	34	38	47	55
K	42	50	66	80
KA	4	4	5	5
KB	4,5	4,5	6	6
KC	3	3	4	4
KD	6	6	8	8
L	48,5	50	50	55
L1	75,5	82	88	93
LT	82,5	89	93	100
M	110	118	146	158
N	96	104	130	130
PA	12	12	15	15
P	44	44	60	70
Q	26	22	24	24
SA	7	7	5	7
T	M6	M6	M8	M10
TA	6,5	6,5	8,5	11
TB	10,5	10,5	13,5	17,8
TC	5,5	5,5	7,5	10
TD	9,5	11	13,5	18,5
TE	3,5	4	4,5	7
UA	6,6	6,6	8,6	8,6
UB	11	11	14	14
UL	7,5	7,5	9	9
V	17	19	15	20
V1	See table 1			
V2				
W	M8x1,25	M8x1,25	M10x1,5	M10x1,5
WL	16	16	20	20
Z	M8x1,25	M8x1,25	M10x1,5	M10x1,5
ZL	20	20	22	22
ZS	M8x1,25	M8x1,25	M10x1,5	M10x1,5
ZZ	M6	M8	M10	M10
ZW	20	20	25	25

Table 1 Bore	V1			V2		
	stroke≤25	25<stroke≤100	100<stroke≤200	stroke≤25	25<stroke≤100	100<stroke≤200
Ø32	24	48	124	38	50	88
Ø40				34	46	84
Ø50				36	48	86
Ø63	28	52	128	38	50	88