

## Series 515

### General

**NAMUR** valves are 5/2 and 4/2 valves and electrovalves, piloted electrically or pneumatically, utilised primarily to operate rotary actuators and wherever there is a **NAMUR** standard installation plan.

The product is classified for use in potentially explosive atmospheres (Directive 2014/34/EU).

**NAMUR** valves have been developed using the latest, technical design solutions which guarantee flexibility and an increased flow rate capacity exceeding that of traditional, spool valves.

In addition, they have been produced with innovative materials which guarantee increased performance.

### IMPORTANT:

Differs from version 514 because it is supplied without a plate.

“NAMUR” interface dimensions:  
according to standard (VDI/VDE 3847 July 2003)

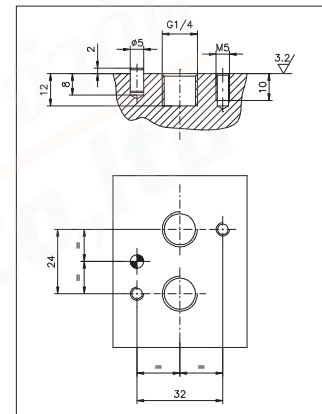

### Construction characteristics

Body	Aluminium
Spacer	Technopolymer
Seals	Nitrile rubber
Springs	Stainless Steel
Operators	Technopolymer
Spools	Steel
Screws	Zinc coated Steel / Stainless steel

### Certifications available:

#### SOLENOID VALVES WITH XMB OR XMC 3GD COIL

: CE II 3G Ex h IIB T4 Gc X  
 : CE II 3D Ex h IIIC T120°C Dc X IP65

#### MECHANICAL AND PNEUMATIC VALVES WITHOUT COILS

: CE II 2G Ex h IIB T5 Gc X  
 : CE II 2D Ex h IIIC T96°C Dc X IP65



**Pneumatic - Differential**

Coding: **M515.52.00.16**

**Operational characteristics**

Fluid	Filtered air. No lubrication needed, if applied it shall be continuous
Max working pressure (bar)	10
Temperature °C	Standard valves (-10 ... +50) Low temperature valves (-30 ... +50) ATEX valves (-20 ... +40)
Flow rate at 6 bar with $\Delta p=1$ (NI/min)	1100
Orifice size (mm)	8
Working ports size	G 1/4"

<b>M</b>	MODEL	<b>⊙</b>	TEMPERATURE OPTIONS
	= Standard valve		= Standard valves (-10 ... +50)
	X = ATEX valve		<b>LT</b> = Low temperature valves (-30 ... +50) = ATEX valves (-20 ... +40)

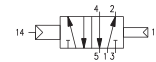
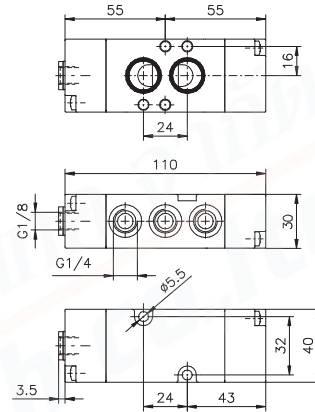

Weight 245 g  
Minimum pilot pressure 2,5 bar  
Maximum fitting torque 9 N/m

**Pneumatic - Pneumatic**

Coding: **M515.52.00.18**

**Operational characteristics**

Fluid	Filtered air. No lubrication needed, if applied it shall be continuous
Max working pressure (bar)	10
Temperature °C	Standard valves (-10 ... +50) Low temperature valves (-30 ... +50) ATEX valves (-20 ... +40)
Flow rate at 6 bar with $\Delta p=1$ (NI/min)	1100
Orifice size (mm)	8
Working ports size	G 1/4"

<b>M</b>	MODEL	<b>⊙</b>	TEMPERATURE OPTIONS
	= Standard valve		= Standard valves (-10 ... +50)
	X = ATEX valve		<b>LT</b> = Low temperature valves (-30 ... +50) = ATEX valves (-20 ... +40)

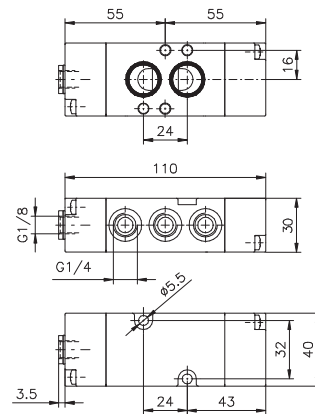

Weight 245 g  
Minimum pilot pressure 2,5 bar  
Maximum fitting torque 9 N/m

AIR DISTRIBUTION

1



**Pneumatic - Spring**

Coding: **M**515.52.00.19**⊙**

Operational characteristics	
Fluid	Filtered air. No lubrication needed, if applied it shall be continuous
Max working pressure (bar)	10
Temperature °C	Standard valves (-10 ... +50) Low temperature valves (-30 ... +50) ATEX valves (-20 ... +40)
Flow rate at 6 bar with Δp=1 (NI/min)	1100
Orifice size (mm)	8
Working ports size	G 1/4"

MODEL		TEMPERATURE OPTIONS	
<b>M</b>	= Standard valve	<b>⊙</b>	= Standard valves (-10 ... +50)
<b>X</b>	= ATEX valve	<b>LT</b>	= Low temperature valves (-30 ... +50)
			= ATEX valves (-20 ... +40)



Weight 245 g  
Minimum pilot pressure 2,5 bar  
Maximum fitting torque 9 N/m

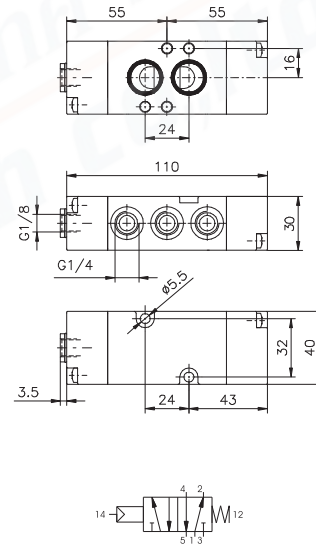



**Solenoid-Solenoid**

Coding: **M515.52.00.35.TC**

**Operational characteristics**

Fluid	Filtered air. No lubrication needed, if applied it shall be continuous
Max working pressure (bar)	10
Temperature °C	Standard valves (-10 ... +50) Low temperature valves (-30 ... +50) ATEX valves (-20 ... +40)
Flow rate at 6 bar with Δp=1 (NI/min)	1100
Orifice size (mm)	8
Working ports size	G 1/4"

<b>M</b>	MODEL -
	= Standard valve
<b>X</b>	= ATEX valve
	VOLTAGE
<b>B04</b>	= 12 VDC
<b>B05</b>	= 24 VDC
<b>B09</b>	= 24 VDC (2W)
<b>B56</b>	= 24V (50-60 Hz)
<b>B57</b>	= 110V (50-60 Hz)
<b>B58</b>	= 230 V (50-60 Hz)
<b>C04</b>	= 12 VDC
<b>C05</b>	= 24 VDC
<b>C09</b>	= 24 VDC (2W)
<b>C56</b>	= 24 V (50-60 Hz)
<b>C57</b>	= 110 V (50-60 Hz)
<b>C58</b>	= 230 V (50-60 Hz)
<b>F04</b>	= 12 VDC
<b>F05</b>	= 24 VDC
<b>F56</b>	= 24 V (50-60 Hz)
<b>F57</b>	= 110 V (50-60 Hz)
<b>F58</b>	= 230 V (50-60 Hz)

<b>C</b>	TEMPERATURE OPTIONS
	= Standard valves (-10 ... +50)
<b>LT</b>	= Low temperature valves (-30 ... +50)
	= ATEX valves (-20 ... +40)

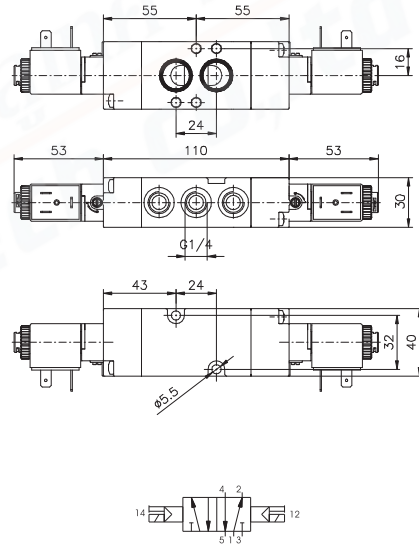

Weight 415 g  
Minimum pilot pressure 2,5 bar  
Maximum fitting torque 9 N/m

1  
AIR DISTRIBUTION



**Solenoid-Differential**

Coding: M515.52.00.36.T.O

Operational characteristics	
Fluid	Filtered air. No lubrication needed, if applied it shall be continuous
Max working pressure (bar)	10
Temperature °C	Standard valves (-10 ... +50) Low temperature valves (-30 ... +50) ATEX valves (-20 ... +40)
Flow rate at 6 bar with Δp=1 (NI/min)	1100
Orifice size (mm)	8
Working ports size	G 1/4"

M	MODEL -	O	TEMPERATURE OPTIONS
	= Standard valve		= Standard valves (-10 ... +50)
	X = ATEX valve		LT = Low temperature valves (-30 ... +50)
VOLTAGE		= ATEX valves (-20 ... +40)	
	B04 = 12 VDC		
	B05 = 24 VDC		
	B09 = 24 VDC (2W)		
	B56 = 24V (50-60 Hz)		
	B57 = 110V (50-60 Hz)		
	B58 = 230 V (50-60 Hz)		
	C04 = 12 VDC		
	C05 = 24 VDC		
T	C09 = 24 VDC (2W)		
	C56 = 24 V (50-60 Hz)		
	C57 = 110 V (50-60 Hz)		
	C58 = 230 V (50-60 Hz)		
	F04 = 12 VDC		
	F05 = 24 VDC		
	F56 = 24 V (50-60 Hz)		
	F57 = 110 V (50-60 Hz)		
	F58 = 230 V (50-60 Hz)		

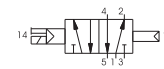
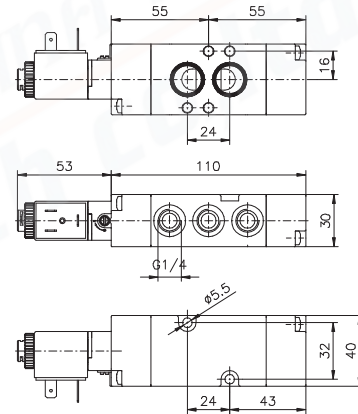

Weight 330 g  
Minimum pilot pressure 2,5 bar  
Maximum fitting torque 9 N/m



Solenoid - Spring

Coding: M515.52.00.39.TC

Operational characteristics

Fluid	Filtered air. No lubrication needed, if applied it shall be continuous
Max working pressure (bar)	10
Temperature °C	Standard valves (-10 ... +50) Low temperature valves (-30 ... +50) ATEX valves (-20 ... +40)
Flow rate at 6 bar with $\Delta p=1$ (NI/min)	1100
Orifice size (mm)	8
Working ports size	G 1/4"

M	MODEL	C	TEMPERATURE OPTIONS
	= Standard valve		= Standard valves (-10 ... +50)
M	X = ATEX valve	C	LT = Low temperature valves (-30 ... +50)
			= ATEX valves (-20 ... +40)
T	VOLTAGE		
	B04 = 12 VDC		
	B05 = 24 VDC		
	B09 = 24 VDC (2W)		
	B56 = 24V (50-60 Hz)		
	B57 = 110V (50-60 Hz)		
	B58 = 230 V (50-60 Hz)		
	C04 = 12 VDC		
	C05 = 24 VDC		
	C09 = 24 VDC (2W)		
	C56 = 24 V (50-60 Hz)		
	C57 = 110 V (50-60 Hz)		
	C58 = 230 V (50-60 Hz)		
	F04 = 12 VDC		
	F05 = 24 VDC		
	F56 = 24 V (50-60 Hz)		
F57 = 110 V (50-60 Hz)			
F58 = 230 V (50-60 Hz)			



Weight 330 g  
Minimum pilot pressure 2,5 bar  
Maximum fitting torque 9 N/m

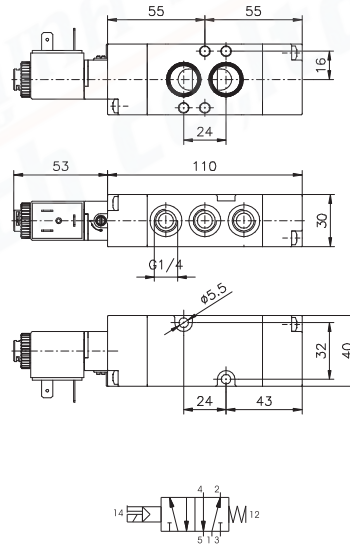

AIR DISTRIBUTION

