

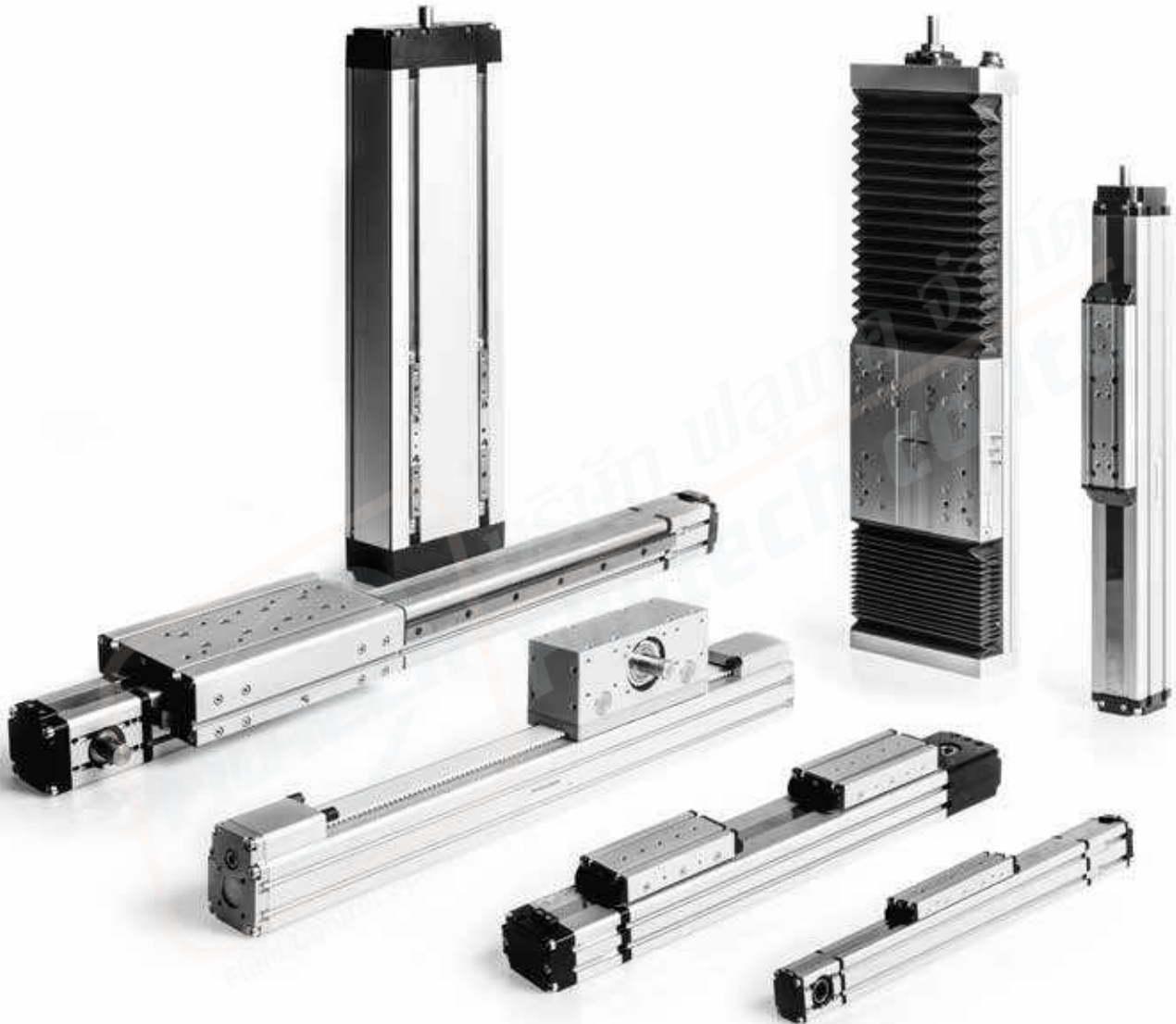

**PNEUMAX**



# LINEAR ACTUATORS

## SERIES 18T

PRECISION AND RELIABILITY

IT-EN-DE

# Index-Inhalt-Indice

## Linear actuator, Linearaktuatoren, Attuatori lineari

Introduction, Allgemeine Hinweise, Introduzione .....	2
Toothed belt Linear actuator, Linearaktuatoren mit Zahnriemenantrieb .....	6
Attuatori lineari - trasmissione a cinghia	
18TB Series, Baureihe 18TB, Serie 18TB .....	7
18TS Series, Baureihe 18TS, Serie 18TS .....	19
18TF42 Series, Baureihe 18TF42, Serie 18TF42 .....	25
18TF42D Series, Baureihe 18TF42D, Serie 18TF42D .....	28
18TZ__L Series, Baureihe 18TZ__L, Serie 18TZ__L .....	31
18TZ__S Series, Baureihe 18TZ__S, 18TZ__S .....	40
Ball screw linear actuator, Linearaktuatoren mit Kugelgewindetrieb .....	47
Attuatori lineari - trasmissione a ricircolo di sfere	
18TV Series, Baureihe 18TV, Serie 18TV .....	48
18VS Series, Baureihe 18VS, Serie 18VS .....	57
18UK Series, Baureihe 18UK, Serie 18UK .....	63
18TL Series, Baureihe 18TL, Serie 18TL .....	72



## Introduction, Einführung, Introduzione

Pneumax S.p.A.

Founded in 1976, **Pneumax S.p.A.** is today one of the leading, international manufacturers of components and systems for industrial automation. It is at the fore front of a group comprised of 22 companies, with over 660 employees worldwide.

Ongoing investment in research and development has allowed **Pneumax** to continually expand its range of standard products and customised solutions, adding to the well-established pneumatic technology, is a range of electric drive actuators and fluid control components.

Seit seiner Gründung 1976 hat sich das Unternehmen Pneumax im Laufe der Zeit eine führende Position auf dem Weltmarkt der Komponenten für industrielle Automation gesichert. Es besteht aus 21 Tochterunternehmen, mit über 660 Mitarbeitern. Fortlaufenden Investitionen in Forschung und Entwicklung haben es Pneumax erlaubt die Bandbreite von Standardprodukten und kundenspezifischen Produkten kontinuierlich zu steigern. Erweitert wird diese gut etablierte Produktpalette durch Elektrozyylinder und Fluid Control Komponenten.

Fondata nel 1976, **PNEUMAX S.p.A.** è oggi uno dei principali player internazionali nel settore dei componenti e sistemi per l'automazione, capofila del Gruppo omonimo costituito da 22 società che occupano oltre 660 collaboratori nel mondo.

Investimenti continui in ricerca e sviluppo hanno permesso a **Pneumax** di ampliare costantemente l'offerta di prodotti standard e soluzioni customizzate, affiancando alla consolidata tecnologia pneumatica l'attuazione elettrica ed i componenti per il controllo dei fluidi.





The ability to provide various technologies and solutions for each of our clients applications is the main objective of our company, making us the ideal strategic partner. What defines us is the “Pneumax Business Attitude”, born out of the capacity to combine industry sectors, technology and our application skills via client collaboration with our business sector and product sector specialists. This represents the main distinguishing factor of what **Pneumax** has to offer.

Die Fähigkeit zur Bereitstellung variabler Technologien, zur Optimierung jeder einzelnen Anwendung, ist tatsächlich das Hauptziel unseres Unternehmens, das uns zum idealen strategischen Partner unserer Kunden macht. Was uns ausmacht ist die “Pneumax Business Attitude”, geboren aus der Fähigkeit zur Kombination von technischen, sektorbezogenen und anwendungsbezogenen Kenntnissen, durch engen Kundenkontakt mit unseren bereichsbezogenen Spezialisten und Produktspezialisten. Dies repräsentiert den wahren Unterschied von **Pneumax**.

La possibilità di fornire differenti tecnologie per ottimizzare le singole applicazioni dei clienti è infatti l'obiettivo dell'azienda che si propone come vero e proprio partner strategico. Quella che definiamo “Pneumax Business Attitude” nasce dalla capacità di combinare competenze settoriali, tecnologiche e applicative attraverso la collaborazione dei clienti con i nostri Business Specialist di settore e con i Product Specialist focalizzati sui prodotti e rappresenta il vero fattore distintivo dell'offerta **Pneumax**.



**Pneumatic technology**  
Pneumatiktechnologie  
Tecnologia pneumatica



**Electric actuation**  
Elektrische Antriebe  
Attuazione elettrica



**Fluid control**  
Fluid control  
Controllo dei fluidi



## Product range, Produktprogramm, Gamma prodotti

Electric actuation, Elektrische Antriebe, Attuazione elettrica

The **Pneumax** range of electric actuators includes a wide selection of electric axes and cylinders. These are available with brushless motors and control drivers from our consolidated partner, Siemens. Alternatively, both the axes and cylinders can be supplied in a 'bare shaft' configuration (Without the motor) or flanged to suit different makes of electric motor giving a wide range of flexibility.

The 18T electric axes series has been designed to ensure speed and accurate motion control to suit most applications without compromising reliability.

These units can be supplied with either tooth belt or ball screw driven configurations with both internal single or external double recirculating ball bearing guides.

Das **Pneumax** Produktprogramm der elektrischen Antriebe beinhaltet eine umfangreiche Auswahl elektrischer Linearachsen und Zylinder. Diese sind verfügbar mit büstenlosen Motoren und Drivern von unserem konsolidierten Partner Siemens. Alternativ bieten wir sowohl Achsen als auch Zylinder ohne Motor, jedoch mit passender Schnittstelle zur den verschiedensten Motorherstellern an und ermöglichen so höchste Flexibilität.

Die Serie 18T wurde entwickelt zur Realisierung von Geschwindigkeit und präziser Bewegungskontrolle, um somit eine Lösung für sehr viele technischen Anwendungen zu bieten.

Diese Einheiten werden entweder mit Zahnriemen oder mit Spindel angetrieben, jeweils mit interner einzelner oder externen doppelten Umlaufführungen.

La gamma di prodotti per l'attuazione elettrica **Pneumax** comprende una vasta gamma di assi e cilindri elettrici fornibili con i relativi motori brushless e driver di controllo. Sia i cilindri che gli assi possono essere forniti senza motori, con motorizzazione Siemens, partner consolidato di **Pneumax** e con flange per altre motorizzazioni per garantire la massima flessibilità.

Gli assi elettrici della serie 18T sono progettati per assicurare in ogni applicazione velocità e precisione nel controllo del moto, garantendo sempre la massima affidabilità. Sono disponibili nelle versioni a cinghia o a vite con ricircolo di sfere e possono essere forniti con guida singola interna o doppia esterna.

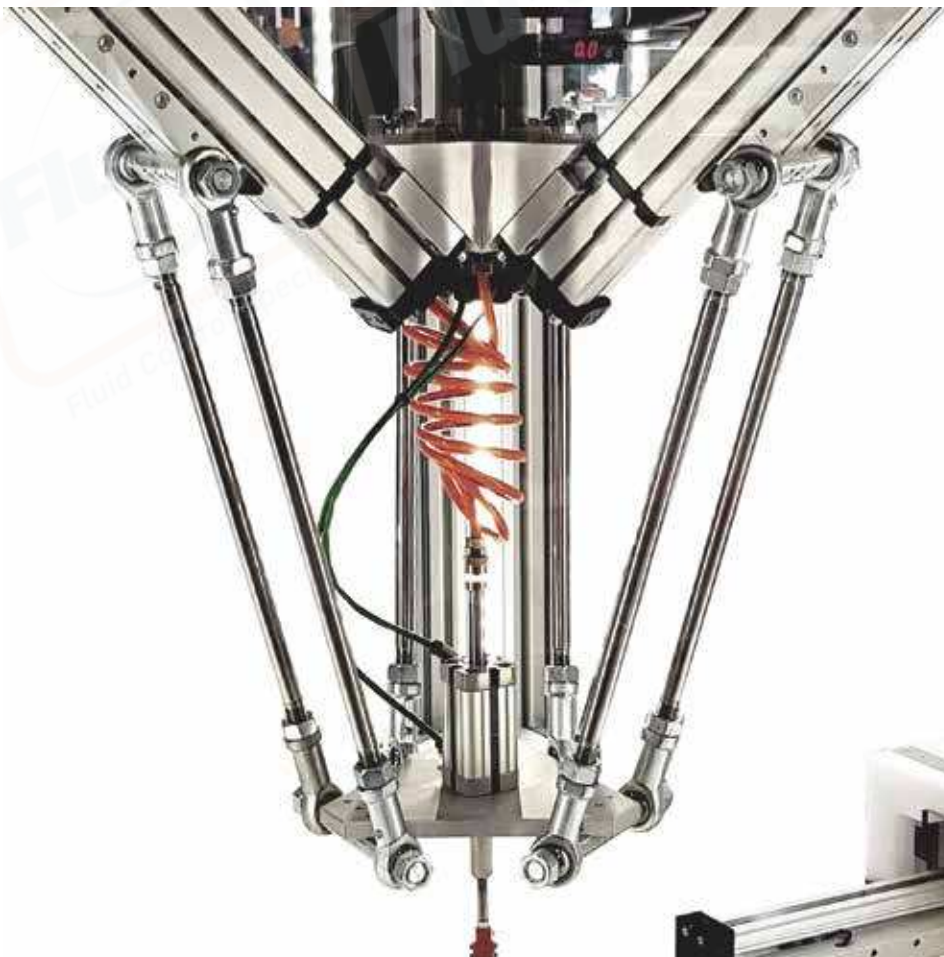



Electrical cylinders with  
linear or parallel motors

Elektrozylinder mit linear oder  
parallel montiertem Motor

Cilindri elettrici con motore  
in linea o in parallelo



Brushless  
Servo motors

Bürstenlose  
Servomotoren

Servo motori  
Brushless

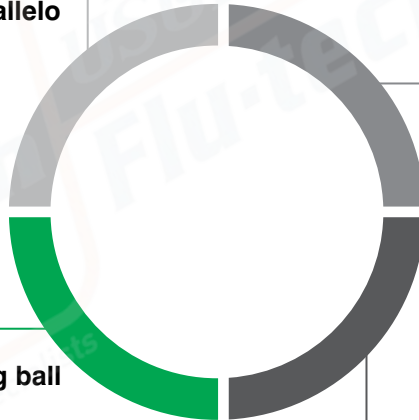

Electrical axes with recirculating ball  
bearing guides and belt drive

Elektrische Linearachsen mit Kugelumlauführung  
und Zahnriementrieb

Assi elettrici a cinghia o a vite con  
ricircolo di sfere



Drivers

Driver

Drivers



## Toothed belt Linear actuator

### Linearaktuatoren mit Zahnriemenantrieb

### Attuatori lineari - trasmissione a cinghia

18TB Series	Baureihe 18TB	Serie 18TB
<p>Linear actuator with body in extruded aluminium, available in 4 sizes.</p> <p>Teeth belt with steel reinforced polyurethane, belt tensioning system.</p> <p>"T" slot for actuator fixing, T slot for proximity switch.</p> <p>Ball rail system.</p> <p>Sealed against pollution.</p> <p>Carriage in aluminium anodized with "T" slot.</p> <p>Motor mount assembly available in two different version.</p>	<p>Linearaktuator, bestehend aus einem Profil mit quadratischem Querschnitt, erhältlich in 4 Baugrößen.</p> <p>Antrieb über Zahnriemen aus mit Stahlilitzen verstärktem Polyurethan, integriertes Spannsystem.</p> <p>Profil aus eloxiertem Aluminium mit T-Nuten zur Befestigung der Achse und Montage der Positionssensoren entlang des Aktuators. Integrierte Kugelumlauführung. Schutz vor eindringendem Schmutz durch Abdeckband aus gehärtetem Edelstahl und Abstreifern am Laufwagen. Laufwagen aus eloxiertem Aluminium mit T-Nuten zur Befestigung der Last. Motorbefestigung mit Außenwelle oder Hohlwelle möglich.</p>	<p>Attuatore lineare a profilo quadro disponibile in 4 taglie. Trasmissione a cinghia dentata in poliuretano rinforzato con trefoli in acciaio, e sistema integrato di tensionamento.</p> <p>Profilato in alluminio anodizzato con cave a "T" per fissaggio dell'asse e montaggio dei sensori di posizione lungo l'attuatore. Guida a ricircolo di sfere integrata. Protezione dalle impurità esterne con bandella in acciaio inox temprato ed elementi a strisciamento sul carrello esterno. Carrello esterno in alluminio anodizzato con cave a "T" per il fissaggio del carico. Possibilità di fissaggio motore con albero maschio o femmina.</p>
18TS Series	Baureihe 18TS	Serie 18TS
<p>Linear frame actuator available in 2 sizes, this is a variant of the 18TB version which includes 2 spherical recirculation guides external to the profile, which increases the loads and moments applicable to the actuator.</p>	<p>Linearaktuator, bestehend aus einem Profil mit quadratischem Querschnitt, erhältlich in 2 Baugrößen.</p> <p>Verfügt im Unterschied zur Version 18TB über 2 am Profil befestigte Kugelumlauführungen, was eine noch höhere Last- und Momentenaufnahme ermöglicht.</p>	<p>Attuatore lineare a profilo quadro disponibile in 2 taglie, variante della versione 18TB, con 2 guide a ricircolo di sfere, esterne fissate al profilato, per un incremento ulteriore di carichi e momenti applicabili all'attuatore.</p>
18TF42 Series	Baureihe 18TF42	Serie 18TF42
<p>Belt driven guided unit using a flat design. teeth belt with steel reinforced polyurethane, belt tensioning system.</p> <p>"T" slot for actuator fixing, T slot for proximity switch.</p> <p>Ball rail system. Sealed against pollution.</p> <p>Carriage in aluminium anodized with "T" slot.</p> <p>Motor mount assembly available in two different version.</p>	<p>Linearaktuator, bestehend aus einem Profil mit flachem Querschnitt.</p> <p>Antrieb über Zahnriemen aus mit Stahlilitzen verstärktem Polyurethan, integriertes Spannsystem.</p> <p>Profil aus eloxiertem Aluminium mit T-Nuten zur Befestigung der Achse und Montage der Positionssensoren entlang des Aktuators.</p> <p>Integrierte Kugelumlauführung.</p> <p>Schutz vor eindringendem Schmutz durch Abdeckband aus gehärtetem Edelstahl und Abstreifern am Laufwagen.</p> <p>Laufwagen aus eloxiertem Aluminium mit T-Nuten zur Befestigung der Last. Motorbefestigung mit Außenwelle oder Hohlwelle möglich.</p>	<p>Attuatore lineare a profilo piatto. Trasmissione a cinghia dentata in poliuretano rinforzato con trefoli in acciaio, e sistema integrato di tensionamento.</p> <p>Profilato in alluminio anodizzato con cave a "T" per fissaggio dell'asse e montaggio dei sensori di posizione lungo l'attuatore. Guida a ricircolo di sfere intergata. Protezione dalle impurità esterne con bandella in acciaio inox temprato ed elementi a strisciamento sul carrello esterno. Carrello esterno in alluminio anodizzato con cave a "T" per il fissaggio del carico. Possibilità di fissaggio motore con albero maschio o femmina.</p>
18TF42D Series	Baureihe 18TF42D	Serie 18TF42D
<p>Linear actuator with flat profile and bidirectional movement.</p>	<p>Verfügt im Unterschied zur Version 18TF42 über 2 Laufwagen, die sich in gegenläufiger Richtung bewegen.</p>	<p>Variante della versione 18TF42, con 2 carrelli esterni con movimento bidirezionale contrapposti.</p>
18TZ__L Series	Baureihe 18TZ__L	Serie 18TZ__L
<p>Linear actuator available in 3 sizes with the advantage of having the motor mounted to the transmission box.</p> <p>The transmission box is fixed while the actuator moves in the case of vertical applications.</p> <p>Teeth belt with steel reinforced polyurethane, belt tensioning system. "T" slot for actuator fixing, T slot for proximity switch.</p> <p>Ball rail system.</p> <p>Motor mount assembly available in two different version.</p>	<p>Linearaktuator, erhältlich in 3 Baugrößen, mit der Besonderheit, dass der Motor am Getriebegehäuse montiert ist.</p> <p>Das Getriebegehäuse ist feststehend, während sich der Aktuator bei Vertikalanwendungen bewegt.</p> <p>Antrieb über Zahnriemen aus mit Stahlilitzen verstärktem Polyurethan, integriertes Spannsystem.</p> <p>Profil aus eloxiertem Aluminium mit T-Nuten zur Montage der Positionssensoren entlang des Aktuators. Integrierte Kugelumlauführung.</p> <p>Motorbefestigung mit Außenwelle oder Hohlwelle möglich.</p>	<p>Attuatore lineare disponibile in 3 taglie con la particolarità di avere il motore fissato alla scatola di trasmissione. La scatola di trasmissione viene fissata mentre è l'attuatore a traslare nel caso di applicazioni verticali.</p> <p>Trasmissione a cinghia dentata in poliuretano rinforzato con trefoli in acciaio, e sistema integrato di tensionamento.</p> <p>Profilato in alluminio anodizzato con cave a "T" per il montaggio dei sensori di posizione lungo l'attuatore. Guida a ricircolo di sfere intergata. Possibilità di fissaggio motore con albero maschio o femmina.</p>
18TZ__S Series	Baureihe 18TZ__S	Serie 18TZ__S
<p>Linear actuator available in 2 sizes, this is a variant of the 18TZ__L version which includes 2 outer ball recirculating guides fixed to the profile, which increases the loads and moments applicable to the actuator.</p>	<p>Linearaktuator, erhältlich in 2 Baugrößen, verfügt im Unterschied zur Version 18TZ__L über 2 am Profil befestigte Kugelumlauführungen, was eine noch höhere Last- und Momentenaufnahme ermöglicht.</p>	<p>Attuatore lineare disponibile in 2 taglie, variante della versione 18TZ__L, con 2 guide a ricircolo di sfere esterne fissate al profilato, per un incremento notevole di carichi e momenti applicabili all'attuatore.</p>

## 18TB42 Series Baureihe 18TB42 | Serie 18TB42

### Belt driven guided linear unit

Linearantrieb mit Zahnriemen und integrierter Kugelumlauführung  
Attuatori lineari a cinghia e guida a ricircolo di sfere

#### TECHNICAL DATA | TECHNISCHE DATEN | DATI TECNICI

Size - Baugröße - Taglia			42x42
Max. speed - Max. Geschwindigkeit - Velocità max		m/s	3
Max. stroke length - Max. Hub - Corsa max		mm	6700
Min. stroke length - Min. Hub - Corsa min		mm	100
Pulley drive ratio - Hub pro Umdrehung - Corsa/giro puleggia		mm	90
Number of teeth of pulley - Zähne der Riemenscheibe - nr. denti puleggia			18
Teeth belt with Steel Reinforced Polyurethane ATL 5 profile clearance 0, width 12 mm ATL 5-Profil Riemen 12 mm Breite 5mm Achsabstand Tipo di cinghia profilo ATL passo 5 larghezza 12 mm			
Max rpm - Max. Drehzahl der Antriebswelle - Max nr. di giri in ingresso		rpm	2000
Base weight - Gewicht bei 0mm Hub - Peso corsa 0 mm		Kg	1,6
Add for 100 mm of stroke - Gewicht bei 100mm Hub - Peso corsa 100 mm		Kg	0,25
Max. load* - Max. Belastung* - Carico max*	Fx	N	460
	Fy	N	1560
	Fz	N	1560
Moments* - Max. Belastungsmoment* - Momenti max*	Mx	Nm	20
	My	Nm	55
	Mz	Nm	55
Inertia moment Aluminum profile - Flächenträgheitsmoment - Momento d'inerzia profilo	Ix	cm <sup>4</sup>	11,8
Inertia moment Aluminum profile - Flächenträgheitsmoment - Momento d'inerzia profilo	Iy	cm <sup>4</sup>	14,2
Repeatability - Wiederholgenauigkeit - Ripetibilità		mm	± 0,05
Max. radial load on input shaft - Max. axillasten an der Antriebswelle Carico assiale max all'albero motore		N	220
No load torque - Leerlaufmoment - Coppia resistente		Nm	0,3

\* Max values for dynamic conditions. Please refer to the following formula when combined loads are applied.

\* Für die Ermittlung der maximalen dynamischen Tragzahlen bei kombinierten Kraftangriffspunkten, nutzen Sie bitte die nebenstehende Berechnungsformel.

\* Valori massimi in condizioni dinamiche. In presenza di carichi combinati riferirsi alla formula per la verifica dei carichi massimi da applicare.

$$\frac{F_{yA}}{F_y} + \frac{F_{zA}}{F_z} + \frac{M_{xA}}{M_x} + \frac{M_{yA}}{M_y} + \frac{M_{zA}}{M_z} \leq 1$$

The A letters show the calculated value.  
Der A Parameter entspricht dem errechneten Wert.  
La lettera A indica i valori complessivi calcolati

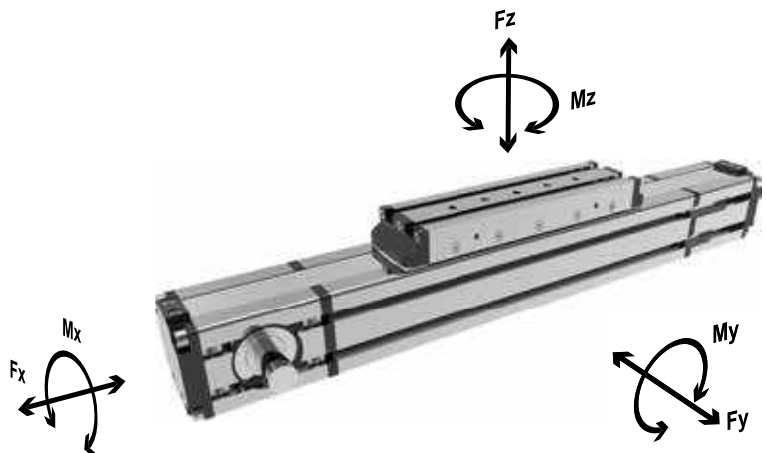



# 18TB42 Series Baureihe 18TB42 | Serie 18TB42

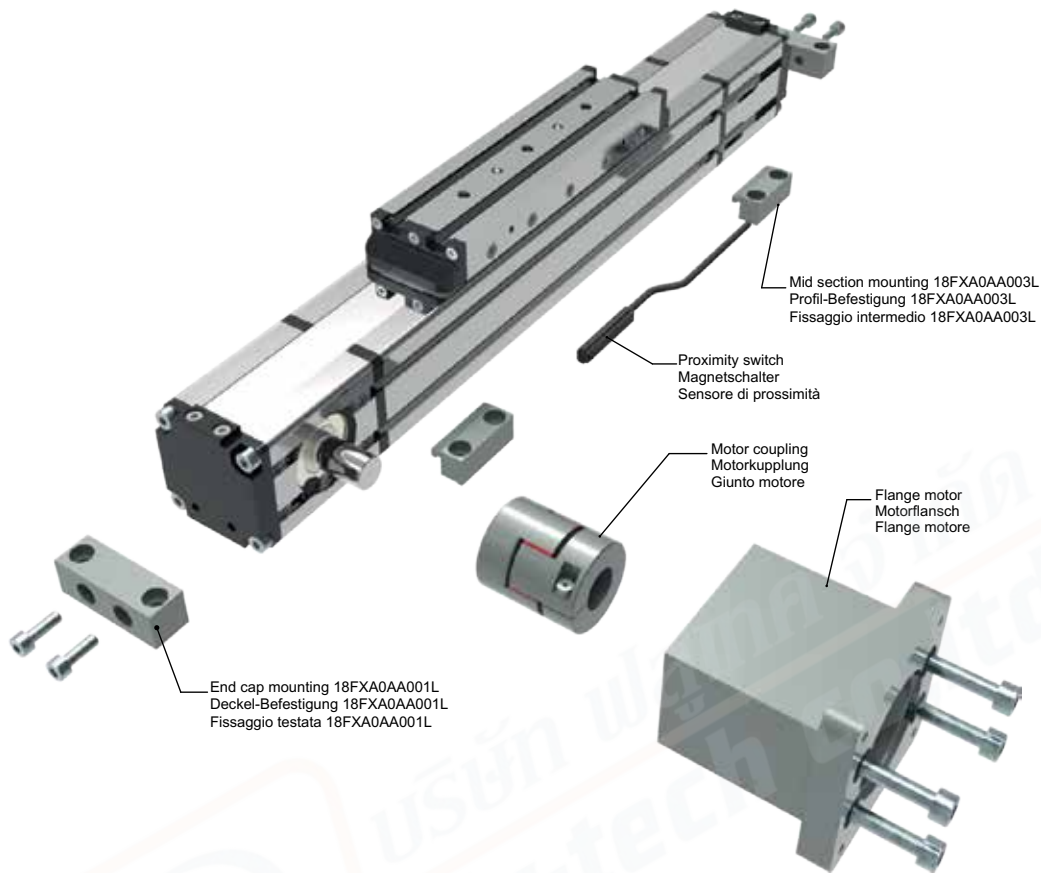

## ORDERING INFORMATION | Bestallangaben Baureihe | Codici per l'ordinazione

Proximity switch		Magnetschalter	Sensore di prossimità
Part nr.   Ident nr.   Cod.	Cable   Kabel   Cavo		Output   Ausgangfunktion   Uscita
1580.HAP	with 2,5 mt cable - NO   mit 2,5 mt Kabel - NO   con cavo 2,5 mt - NA		PNP, Hall
1580.HAN	with 2,5 mt cable - NO   mit 2,5 mt Kabel - NO   con cavo 2,5 mt - NA		NPN, Hall
MHS.P	300 mm with M8 plug in   mit 300 mm Kabel und M8 Stecker   300 mm conn. M8		PNP, Hall

For the technical characteristics, see the General Catalogue, Section 6 "Magnetic sensors" | Die Eigenschaften von Sensoren sind im allgemeinen Katalog, Abschnitt 6 "magnetische Sensoren dargestellt" | Per le caratteristiche dei sensori, vedi il Catalogo Generale, Sezione 6 "Sensori magnetici"

## 18TB42.0900.A

**Stroke mm**  
Hub mm  
Corsa mm

### Shaft | Versionen Antriebeswelle | Versione Albero

- A: Female shaft Ø10 mm with keyshaft  
Hohlwelle mit Ø10 mm und Passfeder  
Albero femmina Ø10 mm con chiavetta
- B: Female shaft Ø12 mm with keyshaft  
Hohlwelle mit Ø12 mm und Passfeder  
Albero femmina Ø12 mm con chiavetta
- C: Male shaft Ø12 mm mount left  
Außenwelle mit Ø12 mm und Wellenposition rechts  
Albero maschio uscita Ø12 mm lato sinistro
- D: Male shaft Ø12 mm mount right  
Außenwelle mit Ø12 mm und Wellenposition links  
Albero maschio uscita Ø12 mm lato destro
- E: Double male shaft Ø12 mm  
Doppelwelle mit Ø12 mm  
Doppio albero maschio Ø12 mm



## 18TB55 Series Baureihe 18TB55 | Serie 18TB55

### Belt driven guided linear unit

Linearantrieb mit Zahnriemen und integrierter Kugelumlaufführung  
Attuatori lineari a cinghia e guida a ricircolo di sfere

#### TECHNICAL DATA | TECHNISCHE DATEN | DATI TECNICI

Size - Baugröße - Taglia			55x55
Max. speed - Max. Geschwindigkeit - Velocità max	m/s		3
Max. stroke length - Max. Hub - Corsa max	mm		6700
Min. stroke length - Min. Hub - Corsa min	mm		100
Pulley drive ratio - Hub pro Umdrehung - Corsa/giro puleggia	mm		120
Number of teeth of pulley - Zähne der Riemenscheibe - nr. denti puleggia			24
Teeth belt with Steel Reinforced Polyurethane ATL 5 profile clearance 0, width 16 mm ATL 5-Profil Riemen 16 mm Breite 5 mm Achsabstand Tipo di cinghia profilo ATL passo 5 larghezza 16 mm			
Max rpm - Max. Drehzahl der Antriebswelle - Max nr. di giri in ingresso	rpm		1500
Base weight - Gewicht bei 0mm Hub - Peso corsa 0 mm	Kg		3,3
Add for 100 mm of stroke - Gewicht bei 100mm Hub - Peso corsa 100 mm	Kg		0,58
Max. load* - Max. Belastung* - Carico max*	Fx	N	820
	Fy	N	1850
	Fz	N	1850
Moments* - Max. Belastungsmoment* - Momenti max*	Mx	Nm	25
	My	Nm	120
	Mz	Nm	120
Inertia moment Aluminum profile - Flächenträgheitmoment - Momento d'inerzia profilo	Ix	cm4	36
	Iy	cm4	45
Repeatability - Wiederholgenauigkeit - Ripetibilità	mm		± 0,05
Max. radial load on input shaft - Max. axillasten an der Antriebswelle Carico assiale max all'albero motore	N		300
No load torque - Leerlaufmoment - Coppia resistente	Nm		>0,4

\* Max values for dynamic conditions. Please refer to the following formula when combined loads are applied.

\* Für die Ermittlung der maximalen dynamischen Tragzahlen bei kombinierten Kraftangriffspunkten, nutzen Sie bitte die nebenstehende Berechnungsformel.

\* Valori massimi in condizioni dinamiche. In presenza di carichi combinati riferirsi alla formula per la verifica dei carichi massimi da applicare.

$$\frac{F_{yA}}{F_y} + \frac{F_{zA}}{F_z} + \frac{M_{xA}}{M_x} + \frac{M_{yA}}{M_y} + \frac{M_{zA}}{M_z} \leq 1$$

The A letters show the calculated value.  
Der A Parameter entspricht dem errechneten Wert.  
La lettera A indica i valori complessivi calcolati

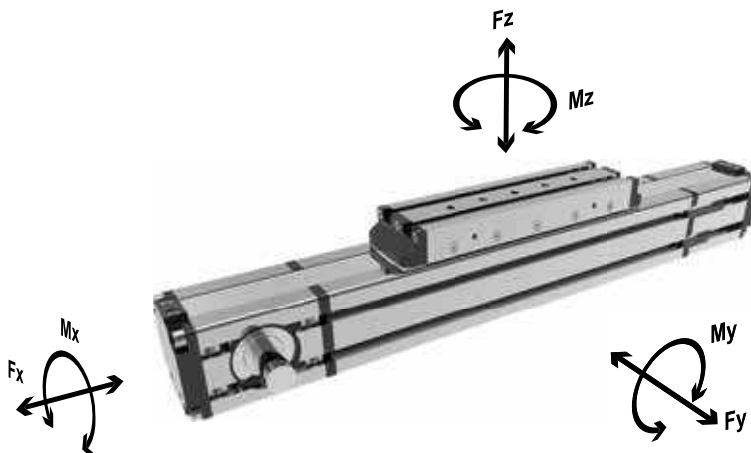

# 18TB55 Series Baureihe 18TB55 | Serie 18TB55

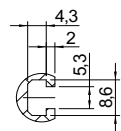
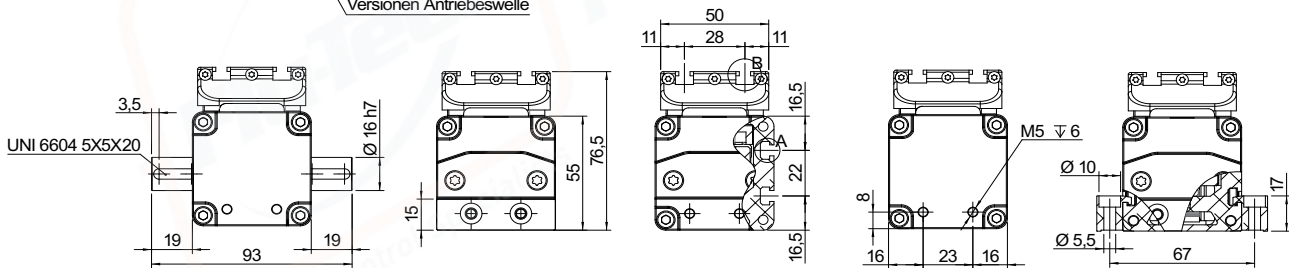
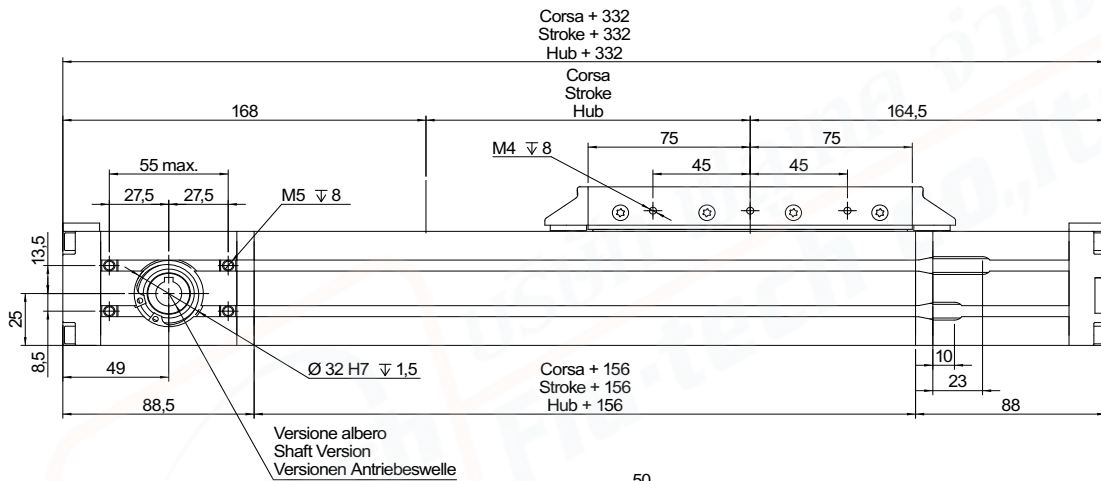
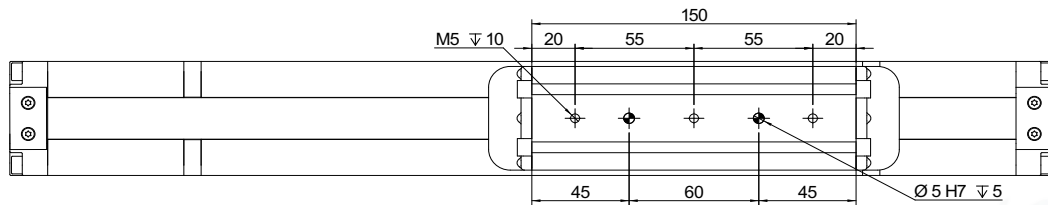
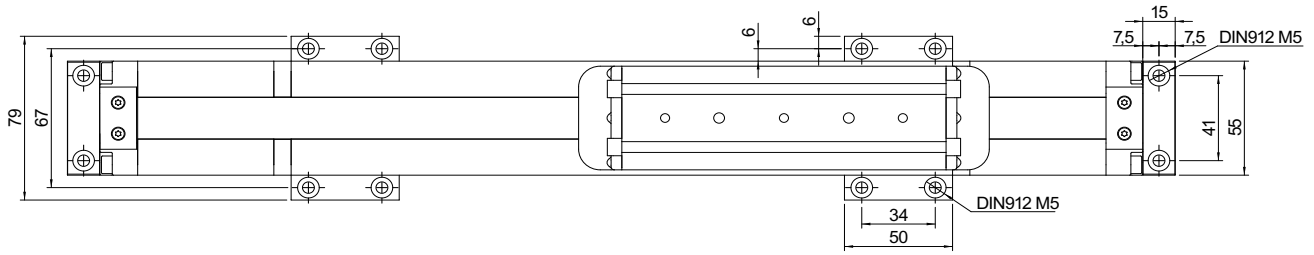

Vista A  
View A  
Ansicht A

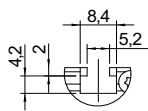

Vista B  
View B  
Ansicht B

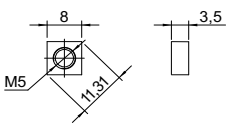

Codice: 18FXDQM05  
Part n.: 18FXDQM05  
Bestellecode: 18FXDQM05

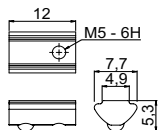

Codice: 18FXDTM05M5  
Part n.: 18FXDTM05M5  
Bestellecode: 18FXDTM05M5



Left mount "C"  
Antriebswelle links "C"  
Lato sinistro "C"



Dual mount "E"  
Doppelwelle "E"  
Doppio albero "E"



Right mount "D"  
Antriebswelle rechts "D"  
Lato destro "D"



# 18TB55 Series Baureihe 18TB55 | Serie 18TB55

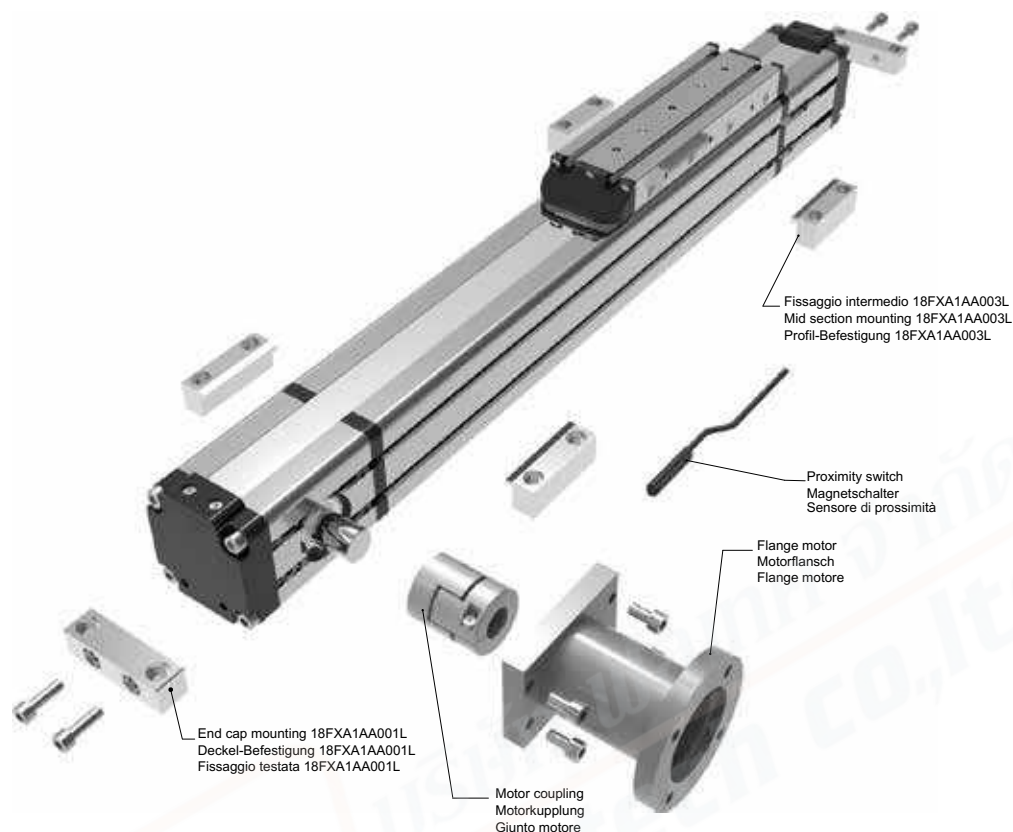

## ORDERING INFORMATION | Bestallangaben Baureihe | Codici per l'ordinazione

### Proximity switch

### Magnetschalter

### Sensore di prossimità

Part nr.   Ident nr.   Cod.	Cable   Kabel   Cavo	Output   Ausgangsfunktion   Uscita
1580.HAP	with 2,5 mt cable - NO   mit 2,5 mt Kabel - NO   con cavo 2,5 mt - NA	PNP, Hall
1580.HAN	with 2,5 mt cable - NO   mit 2,5 mt Kabel - NO   con cavo 2,5 mt - NA	NPN, Hall
MHS.P	300 mm with M8 plug in   mit 300 mm Kabel und M8 Stecker   300 mm conn. M8	PNP, Hall

For the technical characteristics, see the General Catalogue, Section 6 "Magnetic sensors" | Die Eigenschaften von Sensoren sind im allgemeinen Katalog, Abschnitt 6 "magnetische Sensoren dargestellt" | Per le caratteristiche dei sensori, vedi il Catalogo Generale, Sezione 6 "Sensori magnetici"

## 18TB55.0900.A

### Shaft | Versionen Antriebeswelle | Versione Albero

### Stroke mm

Hub mm  
Corsa mm

- A: Female shaft Ø12 mm with keyshaft  
Hohlwelle mit Ø12 mm und Passfeder  
Albero femmina Ø12 mm con chiavetta
- B: Female shaft Ø14 mm with keyshaft  
Hohlwelle mit Ø14 mm und Passfeder  
Albero femmina Ø14 mm con chiavetta
- C: Male shaft Ø16 mm mount left  
Außenwelle mit Ø16 mm und Wellenposition rechts  
Albero maschio uscita Ø16 mm lato sinistro
- D: Male shaft Ø16 mm mount right  
Außenwelle mit Ø16 mm und Wellenposition links  
Albero maschio uscita Ø16 mm lato destro
- E: Double male shaft Ø16 mm  
Doppelwelle mit Ø16 mm  
Doppio albero maschio Ø16 mm

# 18TB80 Series Baureihe 18TB80 | Serie 18TB80

## Belt driven guided linear unit

Linearantrieb mit Zahnriemen und integrierter Kugelumlauführung  
Attuatori lineari a cinghia e guida a ricircolo di sfere

### TECHNICAL DATA | TECHNISCHE DATEN | DATI TECNICI

Size - Baugröße - Taglia			80x80
Max. speed - Max. Geschwindigkeit - Velocità max		m/s	3
Max. stroke length - Max. Hub - Corsa max		mm	6700
Min. stroke length - Min. Hub - Corsa min		mm	100
Pulley drive ratio - Hub pro Umdrehung - Corsa/giro puleggia		mm	160
Number of teeth of pulley - Zähne der Riemenscheibe - nr. denti puleggia			32
Teeth belt with Steel Reinforced Polyurethane ATL 5 profile clearance 0, width 25 mm ATL 5-Profil Riemen 25 mm Breite 5mm Achsabstand Tipo di cinghia profilo ATL passo 5 larghezza 25 mm			
Max rpm - Max. Drehzahl der Antriebswelle - Max nr. di giri in ingresso		rpm	1150
Base weight - Gewicht bei 0mm Hub - Peso corsa 0 mm		Kg	6
Add for 100 mm of stroke - Gewicht bei 100mm Hub - Peso corsa 100 mm		Kg	0,9
Max. load* - Max. Belastung* - Carico max*	Fx	N	1650
	Fy	N	4500
	Fz	N	4500
Moments* - Max. Belastungsmoment* - Momenti max*	Mx	Nm	80
	My	Nm	450
	Mz	Nm	450
Inertia moment Aluminum profile - Flächenträgheitsmoment - Momento d'inerzia profilo	Ix	cm <sup>4</sup>	183
	Iy	cm <sup>4</sup>	226
Repeatability - Wiederholgenauigkeit - Ripetibilità		mm	± 0,05
Max. radial load on input shaft - Max. axillasten an der Antriebswelle Carico assiale max all'albero motore		N	300
	No load torque - Leerlaufmoment - Coppia resistente		Nm

\* Max values for dynamic conditions. Please refer to the following formula when combined loads are applied.

\* Für die Ermittlung der maximalen dynamischen Tragzahlen bei kombinierten Kraftangriffspunkten, nutzen Sie bitte die nebenstehende Berechnungsformel.

\* Valori massimi in condizioni dinamiche. In presenza di carichi combinati riferirsi alla formula per la verifica dei carichi massimi da applicare.

$$\frac{F_{yA}}{F_y} + \frac{F_{zA}}{F_z} + \frac{M_{xA}}{M_x} + \frac{M_{yA}}{M_y} + \frac{M_{zA}}{M_z} \leq 1$$

The A letters show the calculated value.  
Der A Parameter entspricht dem errechneten Wert.  
La lettera A indica i valori complessivi calcolati

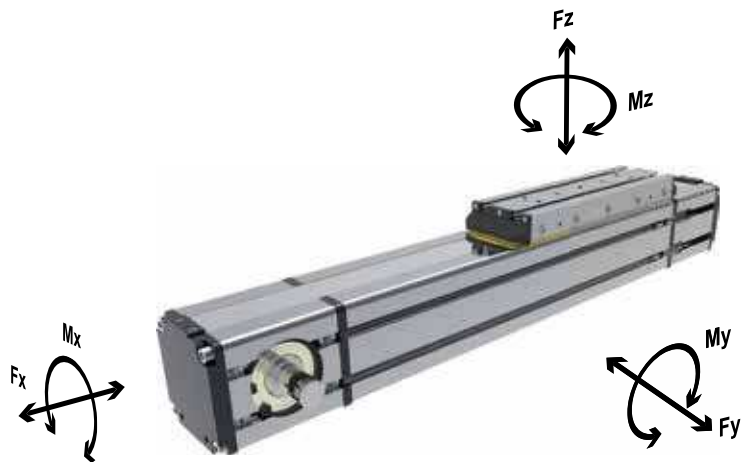



# 18TB80 Series Baureihe 18TB80 | Serie 18TB80

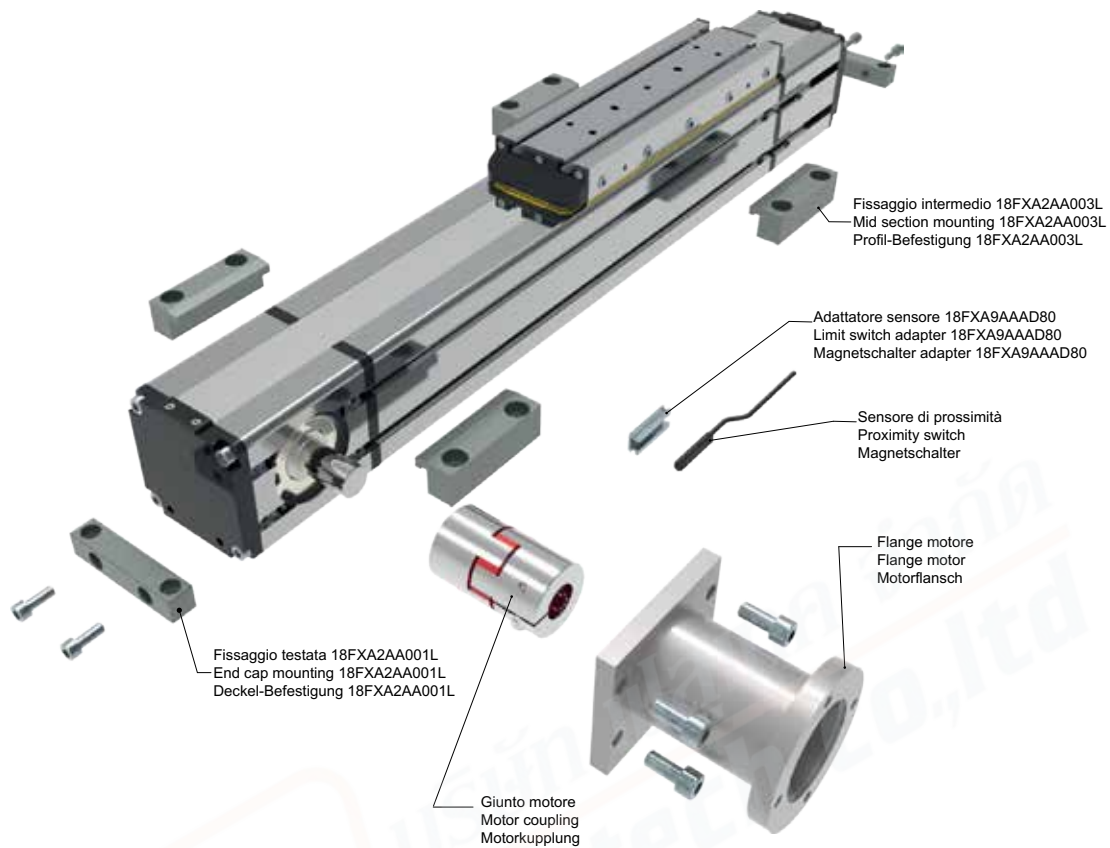

## ORDERING INFORMATION | Bestellangaben Baureihe | Codici per l'ordinazione

Proximity switch		Magnetschalter	Sensore di prossimità
Part nr.   Ident nr.   Cod.	Cable   Kabel   Cavo	Output   Ausgangsfunktion   Uscita	
1580.HAP	with 2,5 mt cable - NO   mit 2,5 mt Kabel - NO   con cavo 2,5 mt - NA	PNP, Hall	
1580.HAN	with 2,5 mt cable - NO   mit 2,5 mt Kabel - NO   con cavo 2,5 mt - NA	NPN, Hall	
MHS.P	300 mm with M8 plug in   mit 300 mm Kabel und M8 Stecker   300 mm conn. M8	PNP, Hall	

For the technical characteristics, see the General Catalogue, Section 6 "Magnetic sensors" | Die Eigenschaften von Sensoren sind im allgemeinen Katalog, Abschnitt 6 "magnetische Sensoren dargestellt" | Per le caratteristiche dei sensori, vedi il Catalogo Generale, Sezione 6 "Sensori magnetici"

## 18TB80.0900.A

### Shaft | Versionen Antriebeswelle | Versione Albero

**Stroke mm**  
Hub mm  
Corsa mm

- A: Female shaft Ø16 mm with keyshaft  
Hohlwelle mit Ø16 mm und Passfeder  
Albero femmina Ø16 mm con chiavetta
- B: Female shaft Ø19 mm with keyshaft  
Hohlwelle mit Ø19 mm und Passfeder  
Albero femmina Ø19 mm con chiavetta
- C: Male shaft Ø19 mm mount left  
Außenwelle mit Ø19 mm und Wellenposition rechts  
Albero maschio uscita Ø19 mm lato sinistro
- D: Male shaft Ø19 mm mount right  
Außenwelle mit Ø19 mm und Wellenposition links  
Albero maschio uscita Ø19 mm lato destro
- E: Double male shaft Ø19 mm  
Doppelwelle mit Ø19 mm  
Doppio albero maschio Ø19 mm



## 18TB105 Series Baureihe 18TB105 | Serie 18TB105

### Belt driven guided linear unit

Linearantrieb mit Zahnriemen und integrierter Kugelumlaufführung  
Attuatori lineari a cinghia e guida a ricircolo di sfere

#### TECHNICAL DATA | TECHNISCHE DATEN | DATI TECNICI

Size - Baugröße - Taglia		105x105
Max. speed - Max. Geschwindigkeit - Velocità max	m/s	3
Max. stroke length - Max. Hub - Corsa max	mm	6700
Min. stroke length - Min. Hub - Corsa min	mm	100
Pulley drive ratio - Hub pro Umdrehung - Corsa/giro puleggia	mm	210
Number of teeth of pulley - Zähne der Riemenscheibe - nr. denti puleggia		21
Teeth belt with Steel Reinforced Polyurethane ATL 10 profile clearance 0, width 32 mm ATL 10-Profil Riemen 32 mm Breite - 10mm Achsabstand Tipo di cinghia profilo ATL passo 10 larghezza 32 mm		
Max rpm - Max. Drehzahl der Antriebswelle - Max nr. di giri in ingresso	rpm	850
Base weight - Gewicht bei 0mm Hub - Peso corsa 0 mm	Kg	12,5
Add for 100 mm of stroke - Gewicht bei 100mm Hub - Peso corsa 100 mm	Kg	1,5
Max. load* - Max. Belastung* - Carico max*	Fx	N 2750
	Fy	N 7500
	Fz	N 7500
Moments* - Max. Belastungsmoment* - Momenti max*	Mx	Nm 120
	My	Nm 700
	Mz	Nm 700
Inertia moment Aluminum profile - Flächenträgheitsmoment - Momento d'inerzia profilo	Ix	cm <sup>4</sup> 440
Inertia moment Aluminum profile - Flächenträgheitsmoment - Momento d'inerzia profilo	Iy	cm <sup>4</sup> 535
Repeatability - Wiederholgenauigkeit - Ripetibilità	mm	± 0,05
Max. radial load on input shaft - Max. axiallylasten an der Antriebswelle Carico assiale max all'albero motore	N	400
No load torque - Leerlaufmoment - Coppia resistente	Nm	>0,8

\* Max values for dynamic conditions. Please refer to the following formula when combined loads are applied.

\* Für die Ermittlung der maximalen dynamischen Tragzahlen bei kombinierten Kraftangriffspunkten, nutzen Sie bitte die nebenstehende Berechnungsformel.

\* Valori massimi in condizioni dinamiche. In presenza di carichi combinati riferirsi alla formula per la verifica dei carichi massimi da applicare.

$$\frac{F_{yA}}{F_y} + \frac{F_{zA}}{F_z} + \frac{M_{xA}}{M_x} + \frac{M_{yA}}{M_y} + \frac{M_{zA}}{M_z} \leq 1$$

The A letters show the calculated value.  
Der A Parameter entspricht dem errechneten Wert.  
La lettera A indica i valori complessivi calcolati

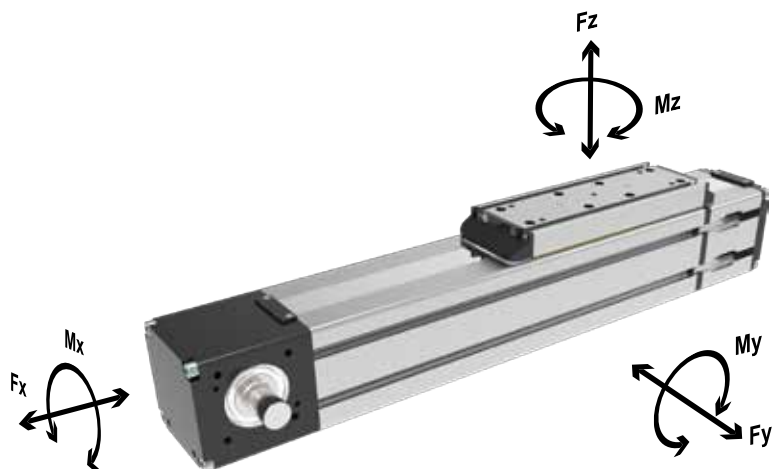

# 18TB105 Series Baureihe 18TB105 | Serie 18TB105

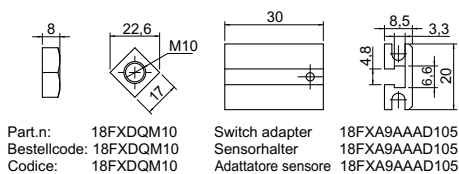
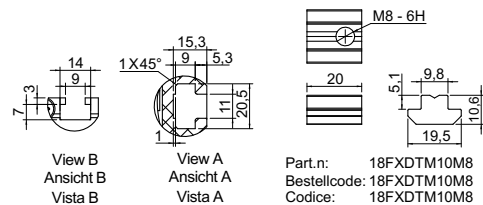
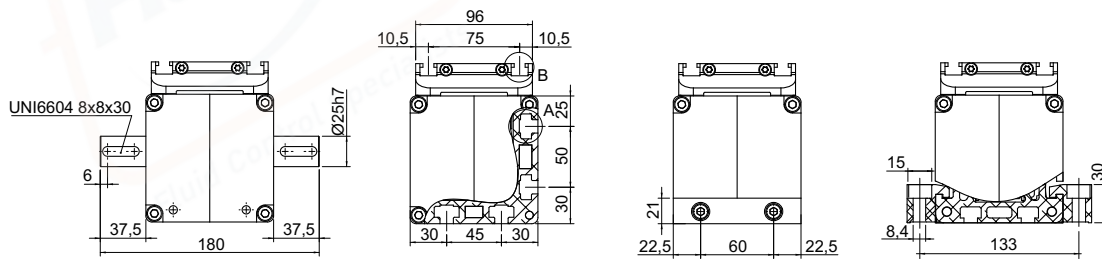
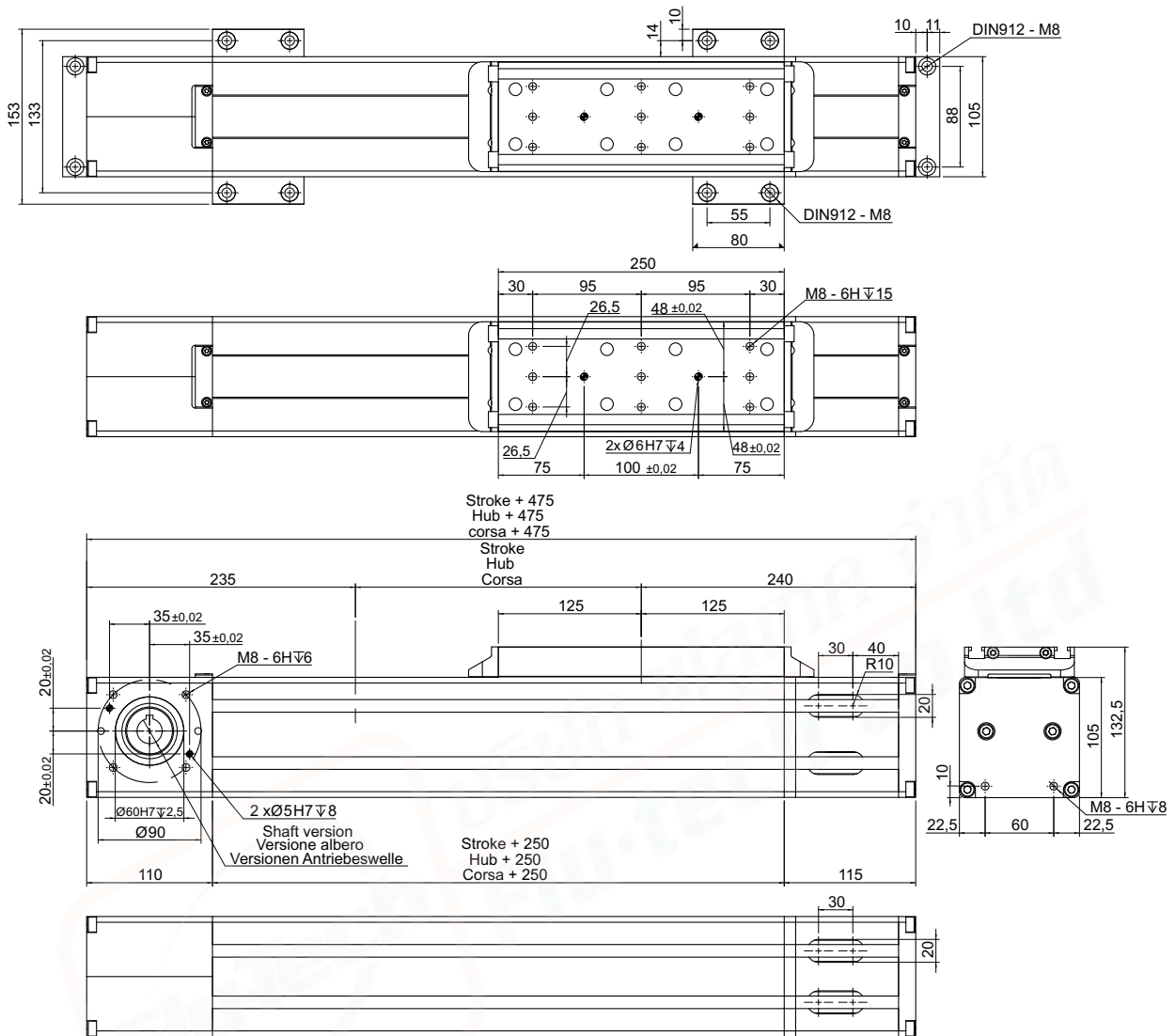

Left mount "C"  
Antriebswelle links "C"  
Lato sinistro "C"



Dual mount "E"  
Doppelwelle "E"  
Doppio albero "E"



Right mount "D"  
Antriebswelle rechts "D"  
Lato destro "D"



# 18TB105 Series Baureihe 18TB105 | Serie 18TB105

ELECTRIC ACTUATION - ELEKTRISCHE ANTRIEBE - ATTUAZIONE ELETTRICA

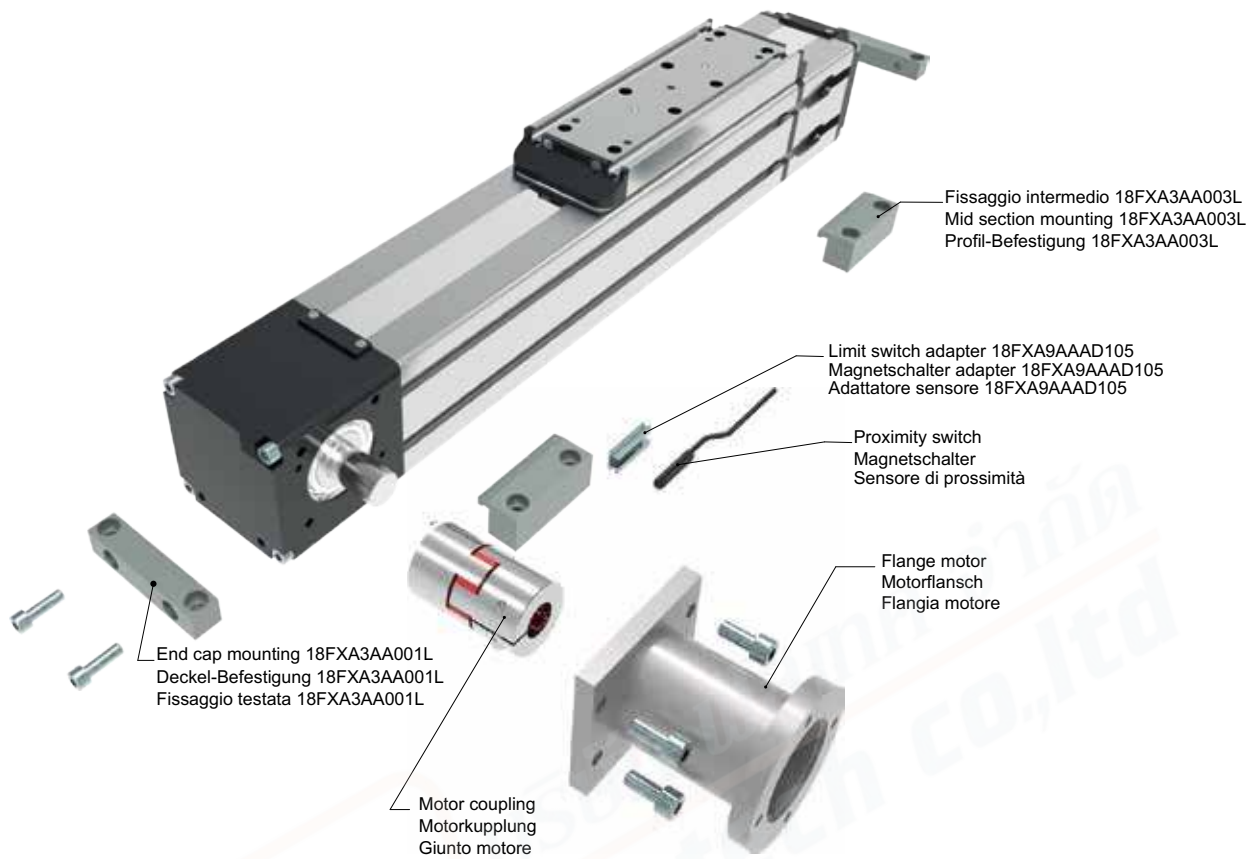

## ORDERING INFORMATION | Bestallangaben Baureihe | Codici per l'ordinazione

Proximity switch		Magnetschalter	Sensore di prossimità
Part nr.   Ident nr.   Cod.	Cable   Kabel   Cavo		Output   Ausgangfunktion   Uscita
1580.HAP	with 2,5 mt cable - NO   mit 2,5 mt Kabel - NO   con cavo 2,5 mt - NA		PNP, Hall
1580.HAN	with 2,5 mt cable - NO   mit 2,5 mt Kabel - NO   con cavo 2,5 mt - NA		NPN, Hall
MHS.P	300 mm with M8 plug in   mit 300 mm Kabel und M8 Stecker   300 mm conn. M8		PNP, Hall

For the technical characteristics, see the General Catalogue, Section 6 "Magnetic sensors" | Die Eigenschaften von Sensoren sind im allgemeinen Katalog, Abschnitt 6 "magnetische Sensoren dargestellt" | Per le caratteristiche dei sensori, vedi il Catalogo Generale, Sezione 6 "Sensori magnetici"

## 18TB105 - 0900 - A

**Shaft** | Versionen Antriebeswelle | Versione Albero

**Stroke mm**  
Hub mm  
Corsa mm

- A: Female shaft Ø22 mm with keyshaft  
Hohlwelle mit Ø22 mm und Passfeder  
Albero femmina Ø22 mm con chiavetta
- B: Female shaft Ø25 mm with keyshaft  
Hohlwelle mit Ø25 mm und Passfeder  
Albero femmina Ø25 mm con chiavetta
- C: Male shaft Ø25 mm mount left  
Außenwelle mit Ø25 mm und Wellenposition rechts  
Albero maschio uscita Ø16 mm lato sinistro
- D: Male shaft Ø25 mm mount right  
Außenwelle mit Ø25 mm und Wellenposition links  
Albero maschio uscita Ø25 mm lato destro
- E: Double male shaft Ø25 mm  
Doppelwelle mit Ø25 mm  
Doppio albero maschio Ø25 mm

# 18TS55 Series Baureihe 18TS55 | Serie 18TS55

## Belt driven guided linear unit

Linearantrieb mit Zahnriemen und integrierter Kugelumlaufführung  
Attuatori lineari a cinghia e guida a ricircolo di sfere

### TECHNICAL DATA | TECHNISCHE DATEN | DATI TECNICI

Size - Baugröße - Taglia			55x55
Max. speed - Max. Geschwindigkeit - Velocità max		m/s	3
Max. stroke length - Max. Hub - Corsa max		mm	6700
Min. stroke length - Min. Hub - Corsa min		mm	100
Pulley drive ratio - Hub pro Umdrehung - Corsa/giro puleggia		mm	120
Number of teeth of pulley - Zähne der Riemenscheibe - nr. denti puleggia			24
Teeth belt with Steel Reinforced Polyurethane ATL 5 profile clearance 0, width 16 mm ATL 5-Profil Riemen 16 mm Breite 5mm Achsabstand Tipo di cinghia profilo ATL passo 5 larghezza 16 mm			
Max rpm - Max. Drehzahl der Antriebswelle - Max nr. di giri in ingresso		rpm	1500
Base weight - Gewicht bei 0mm Hub - Peso corsa 0 mm		Kg	4,8
Add for 100 mm of stroke - Gewicht bei 100mm Hub - Peso corsa 100 mm		Kg	0,37
Max. load* - Max. Belastung - Carico max*	Fx	N	820
	Fy	N	10800
	Fz	N	10800
Moments* - Max. Belastungsmoment* - Momenti max*	Mx	Nm	395
	My	Nm	480
	Mz	Nm	480
Inertia moment Aluminum profile - Flächenträgheitmoment - Momento d'inerzia profilo	Ix	cm <sup>4</sup>	36
	Iy	cm <sup>4</sup>	45
Repeatability - Wiederholgenauigkeit - Ripetibilità		mm	± 0,05
Max. radial load on input shaft - Max. axillasten an der Antriebswelle Carico assiale max all'albero motore		N	300
	No load torque - Leerlaufmoment - Coppia resistente		Nm

\* Max values for dynamic conditions. Please refer to the following formula when combined loads are applied.

\* Für die Ermittlung der maximalen dynamischen Tragzahlen bei kombinierten Kraftangriffspunkten, nutzen Sie bitte die nebenstehende Berechnungsformel.

\* Valori massimi in condizioni dinamiche. In presenza di carichi combinati riferirsi alla formula per la verifica dei carichi massimi da applicare.

$$\frac{F_{yA}}{F_y} + \frac{F_{zA}}{F_z} + \frac{M_{xA}}{M_x} + \frac{M_{yA}}{M_y} + \frac{M_{zA}}{M_z} \leq 1$$

The A letters show the calculated value.  
Der A Parameter entspricht dem errechneten Wert.  
La lettera A indica i valori complessivi calcolati

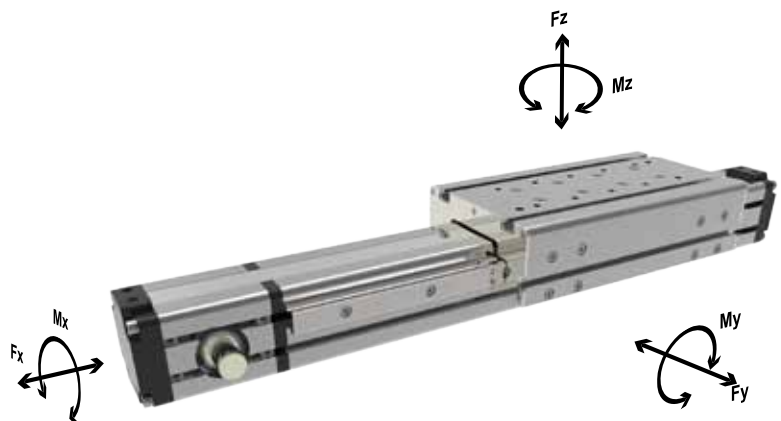



# 18TS55 Series Baureihe 18TS55 | Serie 18TS55

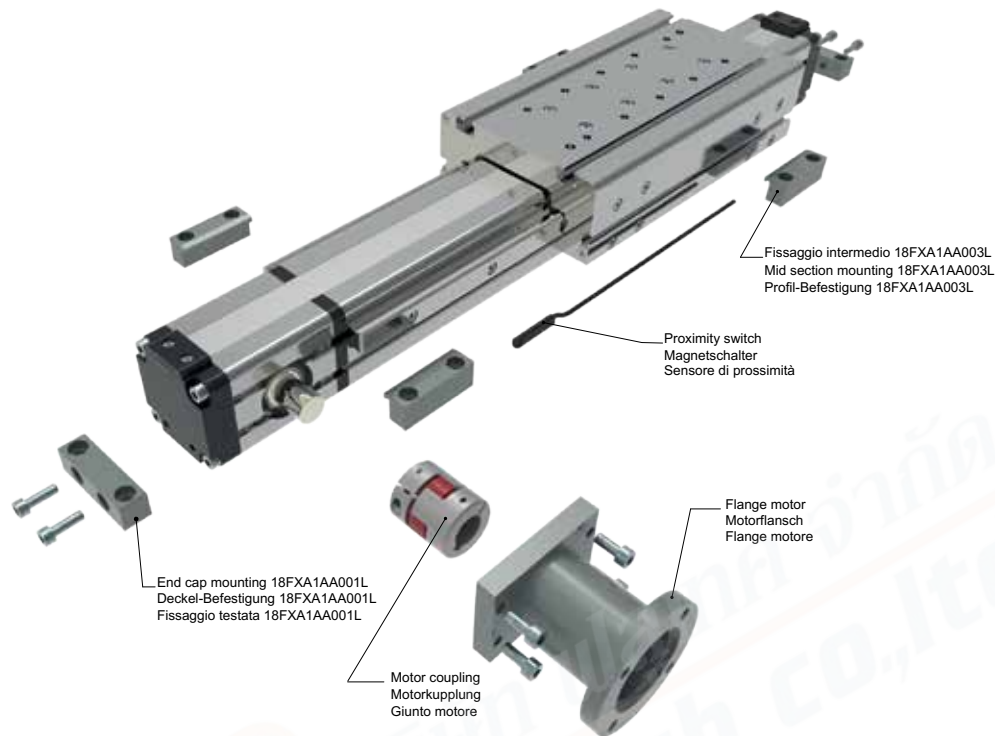

## ORDERING INFORMATION | Bestallangaben Baureihe | Codici per l'ordinazione

Proximity switch		Magnetschalter	Sensore di prossimità
Part nr.   Ident nr.   Cod.	Cable   Kabel   Cavo	Output   Ausgangfunktion   Uscita	
1580.HAP	with 2,5 mt cable - NO   mit 2,5 mt Kabel - NO   con cavo 2,5 mt - NA	PNP, Hall	
1580.HAN	with 2,5 mt cable - NO   mit 2,5 mt Kabel - NO   con cavo 2,5 mt - NA	NPN, Hall	
MHS.P	300 mm with M8 plug in   mit 300 mm Kabel und M8 Stecker   300 mm conn. M8	PNP, Hall	

For the technical characteristics, see the General Catalogue, Section 6 "Magnetic sensors" | Die Eigenschaften von Sensoren sind im allgemeinen Katalog, Abschnitt 6 "magnetische Sensoren dargestellt" | Per le caratteristiche dei sensori, vedi il Catalogo Generale, Sezione 6 "Sensori magnetici"

## 18TS55.0900.A

### Stroke mm

Hub mm  
Corsa mm

### Shaft | Versionen Antriebeswelle | Versione Albero

- A: Female shaft Ø12 mm with keyshaft  
Hohlwelle mit Ø12 mm und Passfeder  
Albero femmina Ø12 mm con chiavetta
- B: Female shaft Ø14 mm with keyshaft  
Hohlwelle mit Ø14 mm und Passfeder  
Albero femmina Ø14 mm con chiavetta
- C: Male shaft Ø16 mm mount left  
Außenwelle mit Ø16 mm und Wellenposition rechts  
Albero maschio uscita Ø16 mm lato sinistro
- D: Male shaft Ø16 mm mount right  
Außenwelle mit Ø16 mm und Wellenposition links  
Albero maschio uscita Ø16 mm lato destro
- E: Double male shaft Ø16 mm  
Doppelwelle mit Ø16 mm  
Doppio albero maschio Ø16 mm



## 18TS80 Series Baureihe 18TS80 | Serie 18TS80

### Belt driven guided linear unit

Linearantrieb mit Zahnriemen und integrierter Kugelumlauführung  
Attuatori lineari a cinghia e guida a ricircolo di sfere

#### TECHNICAL DATA | TECHNISCHE DATEN | DATI TECNICI

Size - Baugröße - Taglia			80x80
Max. speed - Max. Geschwindigkeit - Velocità max		m/s	3
Max. stroke length - Max. Hub - Corsa max		mm	6700
Min. stroke length - Min. Hub - Corsa min		mm	100
Pulley drive ratio - Hub pro Umdrehung - Corsa/giro puleggia		mm	160
Number of teeth of pulley - Zähne der Riemenscheibe - nr. denti puleggia			32
Teeth belt with Steel Reinforced Polyurethane ATL 5 profile clearance 0, width 25 mm ATL 5-Profil Riemen 25mm Breite 5mm Achsabstand Tipo di cinghia profilo ATL passo 5 larghezza 25 mm			
Max rpm - Max. Drehzahl der Antriebswelle - Max nr. di giri in ingresso		rpm	1000
Base weight - Gewicht bei 0mm Hub - Peso corsa 0 mm		Kg	8,8
Add for 100 mm of stroke - Gewicht bei 100mm Hub - Peso corsa 100 mm		Kg	1,1
Max. load* - Max. Belastung - Carico max*	Fx	N	1950
	Fy	N	20200
	Fz	N	20200
Moments* - Max. Belastungsmoment* - Momenti max*	Mx	Nm	620
	My	Nm	730
	Mz	Nm	730
Inertia moment Aluminum profile - Flächenträgheit-moment - Momento d'inerzia profilo	Ix	cm4	183
Inertia moment Aluminum profile - Flächenträgheit-moment - Momento d'inerzia profilo	Iy	cm4	226
Repeatability - Wiederholgenauigkeit - Ripetibilità		mm	± 0,05
Max. radial load on input shaft - Max. axiallylasten an der Antriebswelle Carico assiale max all'albero motore		N	300
No load torque - Leerlaufmoment - Coppia resistente		Nm	>0,7

\* Max values for dynamic conditions. Please refer to the following formula when combined loads are applied.

\* Für die Ermittlung der maximalen dynamischen Tragzahlen bei kombinierten Kraftangriffspunkten, nutzen Sie bitte die nebenstehende Berechnungsformel.

\* Valori massimi in condizioni dinamiche. In presenza di carichi combinati riferirsi alla formula per la verifica dei carichi massimi da applicare.

$$\frac{F_{yA}}{F_y} + \frac{F_{zA}}{F_z} + \frac{M_{xA}}{M_x} + \frac{M_{yA}}{M_y} + \frac{M_{zA}}{M_z} \leq 1$$

The A letters show the calculated value.  
Der A Parameter entspricht dem errechneten Wert.  
La lettera A indica i valori complessivi calcolati

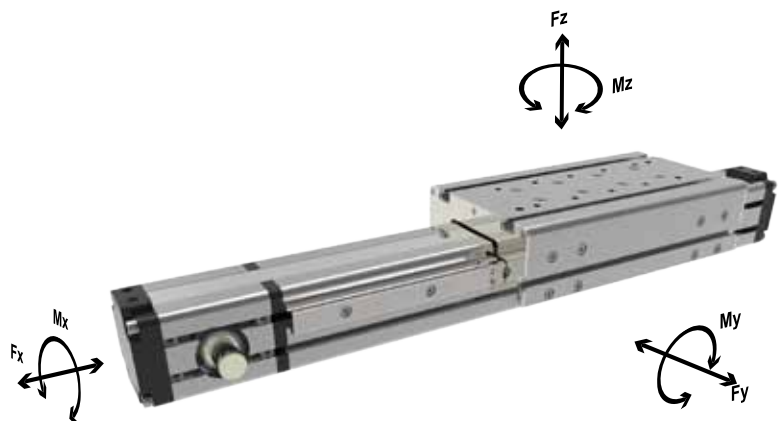

# 18TS80 Series Baureihe 18TS80 | Serie 18TS80

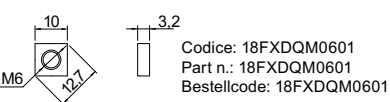
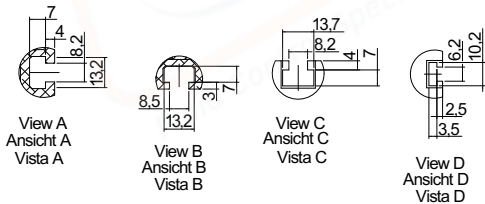
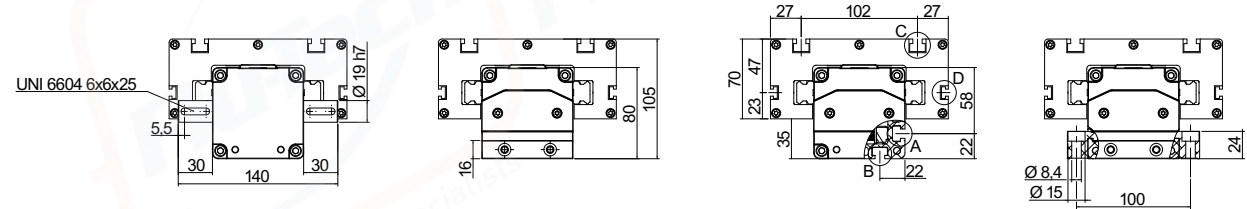
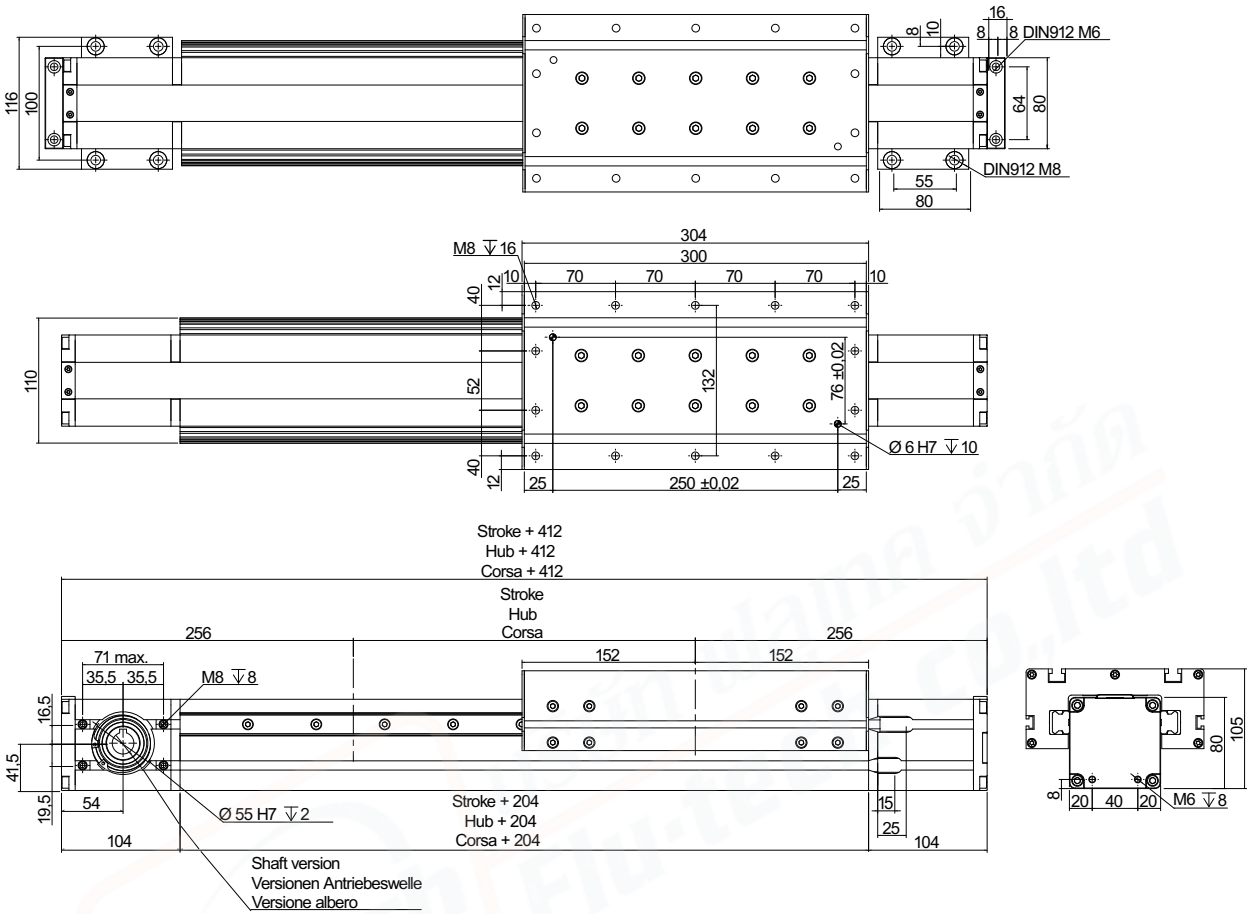

Left mount "D"  
Antriebswelle links "D"  
Lato sinistro "D"



Dual mount "E"  
Doppelwelle "E"  
Doppio albero "E"



Right mount "D"  
Antriebswelle rechts "D"  
Lato destro "D"

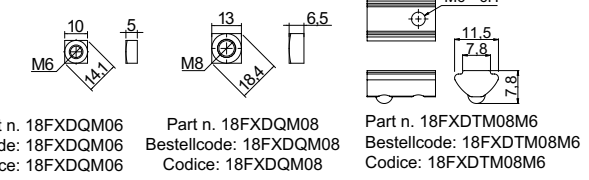



# 18TS80 Series Baureihe 18TS80 | Serie 18TS80

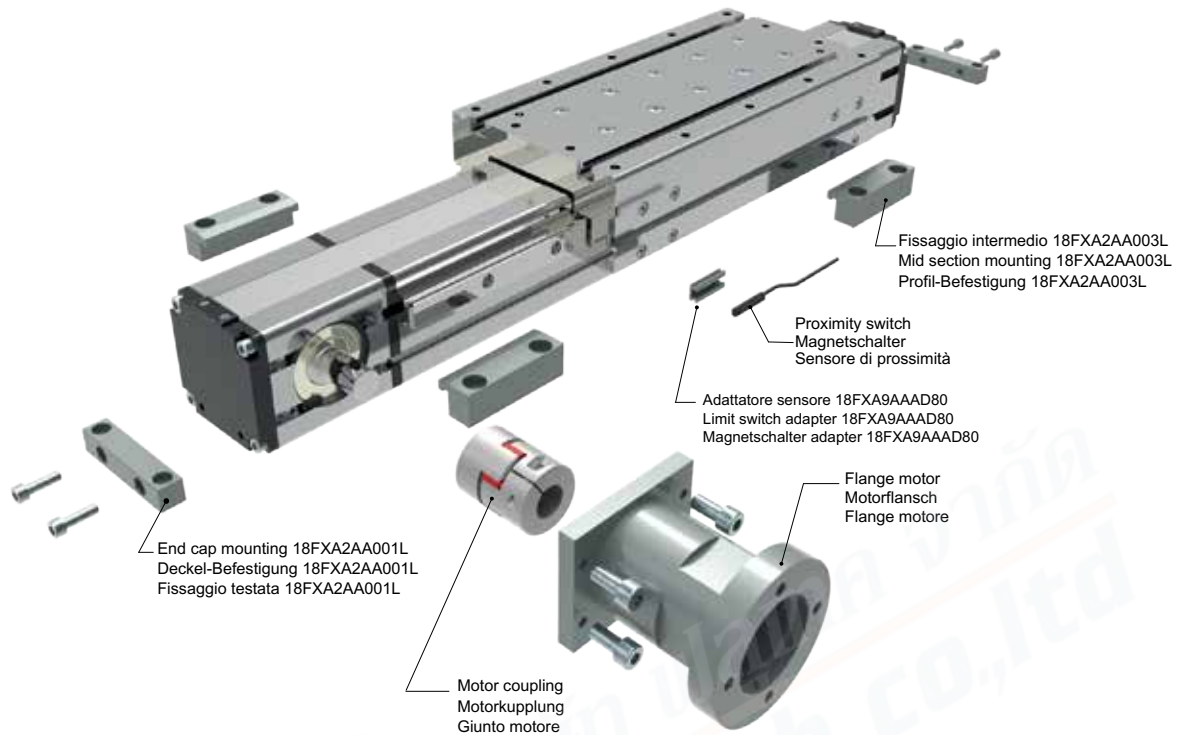

## ORDERING INFORMATION | Bestallangaben Baureihe | Codici per l'ordinazione

Proximity switch		Magnetschalter	Sensore di prossimità
Part nr.   Ident nr.   Cod.	Cable   Kabel   Cavo	Output   Ausgangfunktion   Uscita	
1580.HAP	with 2,5 mt cable - NO   mit 2,5 mt Kabel - NO   con cavo 2,5 mt - NA	PNP, Hall	
1580.HAN	with 2,5 mt cable - NO   mit 2,5 mt Kabel - NO   con cavo 2,5 mt - NA	NPN, Hall	
MHS.P	300 mm with M8 plug in   mit 300 mm Kabel und M8 Stecker   300 mm conn. M8	PNP, Hall	

For the technical characteristics, see the General Catalogue, Section 6 "Magnetic sensors" | Die Eigenschaften von Sensoren sind im allgemeinen Katalog, Abschnitt 6 "magnetische Sensoren dargestellt" | Per le caratteristiche dei sensori, vedi il Catalogo Generale, Sezione 6 "Sensori magnetici"

## 18TS80.0900.A

**Stroke mm**  
Hub mm  
Corsa mm

### Shaft | Versionen Antriebeswelle | Versione Albero

- A: Female shaft Ø16 mm with keyshaft  
Hohlwelle mit Ø16 mm und Passfeder  
Albero femmina Ø16 mm con chiavetta
- B: Female shaft Ø19 mm with keyshaft  
Hohlwelle mit Ø19 mm und Passfeder  
Albero femmina Ø19 mm con chiavetta
- C: Male shaft Ø19 mm mount left  
Außenwelle mit Ø19 mm und Wellenposition rechts  
Albero maschio uscita Ø19 mm lato sinistro
- D: Male shaft Ø19 mm mount right  
Außenwelle mit Ø19 mm und Wellenposition links  
Albero maschio uscita Ø19 mm lato destro
- E: Double male shaft Ø19 mm  
Doppelwelle mit Ø19 mm  
Doppio albero maschio Ø19 mm

# 18TF42 Series Baureihe 18TF42 | Serie 18TF42

## Belt driven guided linear unit

Linearantrieb mit Zahnriemen und integrierter Kugelumlaufführung  
Attuatori lineari a cinghia e guida a ricircolo di sfere

### TECHNICAL DATA | TECHNISCHE DATEN | DATI TECNICI

Size - Baugröße - Taglia		42x75	
Max. speed - Max. Geschwindigkeit - Velocità max	m/s	3	
Max. stroke length - Max. Hub - Corsa max	mm	6000	
Min. stroke length - Min. Hub - Corsa min	mm	100	
Pulley drive ratio - Hub pro Umdrehung - Corsa/giro puleggia	mm	130	
Number of teeth of pulley - Zähne der Riemenscheibe - nr. denti puleggia		26	
Teeth belt with Steel Reinforced Polyurethane ATL 5 profile clearance 0, width 12 mm ATL 5-Profil Riemen 12 mm Breite 5mm Achsabstand Tipo di cinghia profilo ATL passo 5 larghezza 12 mm			
Max rpm - Max. Drehzahl der Antriebswelle - Max nr. di giri in ingresso	rpm	1400	
Version - Version - Versione		H	L
Base weight - Gewicht bei 0mm Hub - Peso corsa 0 mm	Kg	2,8	2,4
Add for 100 mm of stroke - Gewicht bei 100mm Hub - Peso corsa 100 mm	Kg	0,32	0,32
Max. load* - Max. Belastung*- Carico max*	Fx	N	615
	Fy	N	1275
	Fz	N	1275
Moments* - Max. Belastungsmoment* - Momenti max*	Mx	Nm	18
	My	Nm	110
	Mz	Nm	110
Inertia moment Aluminum profile - Flächenträgheitsmoment Momento d'inerzia profilo	Ix	cm4	28
	Iy	cm4	37
Repeatability - Wiederholgenauigkeit - Ripetibilità	mm	± 0,05	
Max. radial load on input shaft - Max. axiallylasten an der Antriebswelle Carico assiale max all'albero motore	N	250	
No load torque - Leerlaufmoment - Coppia resistente	Nm	>0,3	

\* Max values for dynamic conditions. Please refer to the following formula when combined loads are applied.

\* Für die Ermittlung der maximalen dynamischen Tragzahlen bei kombinierten Kraftangriffspunkten, nutzen Sie bitte die nebenstehende Berechnungsformel.

\* Valori massimi in condizioni dinamiche. In presenza di carichi combinati riferirsi alla formula per la verifica dei carichi massimi da applicare.

$$\frac{F_{yA}}{F_y} + \frac{F_{zA}}{F_z} + \frac{M_{xA}}{M_x} + \frac{M_{yA}}{M_y} + \frac{M_{zA}}{M_z} \leq 1$$

The A letters show the calculated value.  
Der A Parameter entspricht dem errechneten Wert.  
La lettera A indica i valori complessivi calcolati

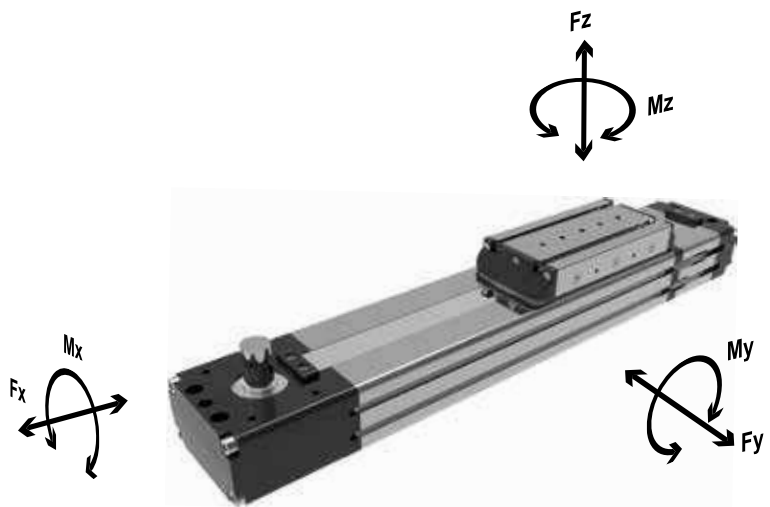



# 18TF42 Series Baureihe 18TF42 | Serie 18TF42

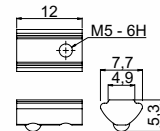
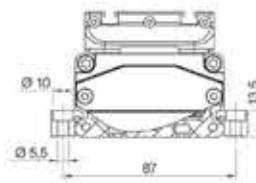
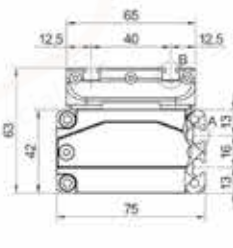
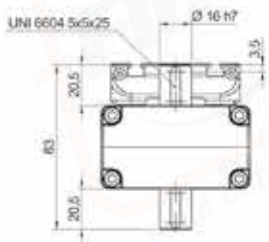
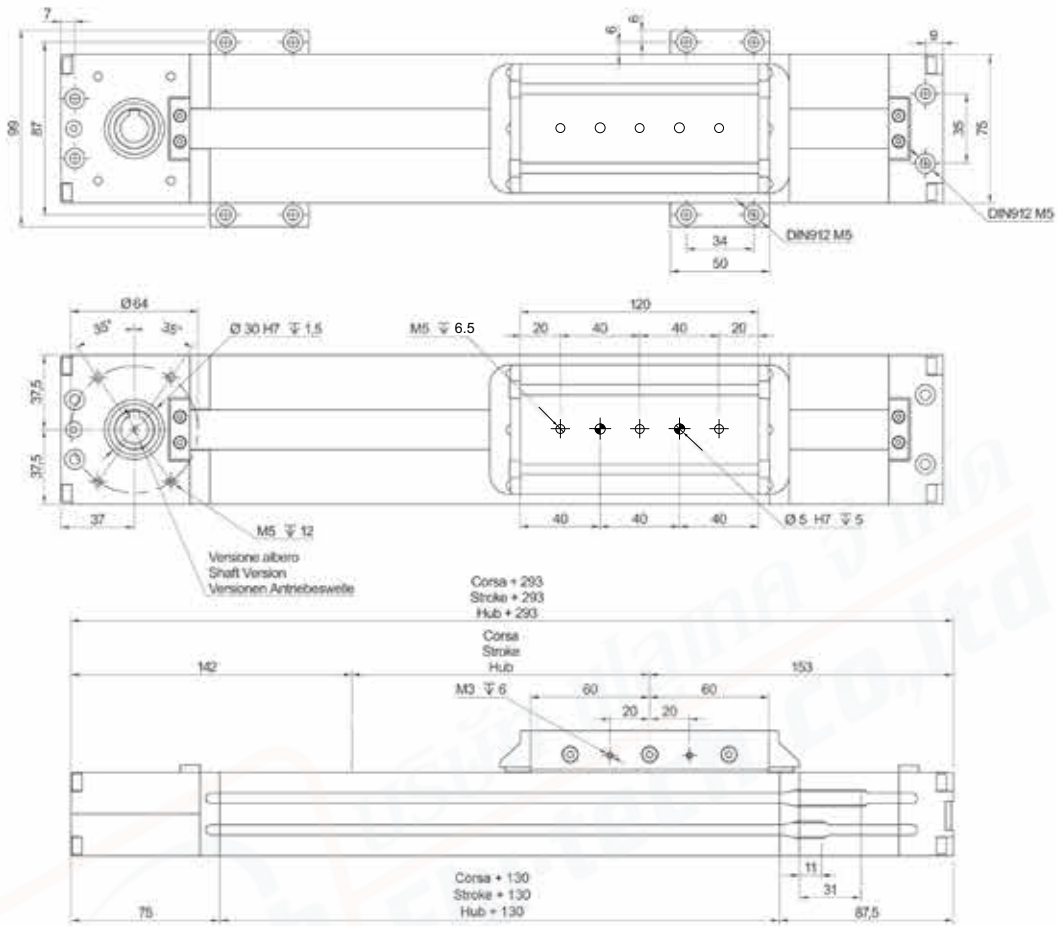

Codice: 18FXDTM05M5  
Part n.: 18FXDTM05M5  
Bestellecode: 18FXDTM05M5

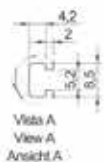

View A  
Ansicht A

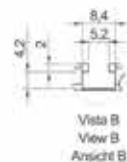

View B  
Ansicht B

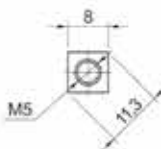

Codice: 18FXDQM05  
Part n.: 18FXDQM05  
Bestellecode: 18FXDQM05

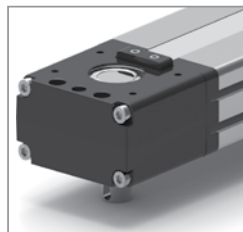

Down mount "C"  
Antriebsswelle unten "C"  
Lato sotto "C"

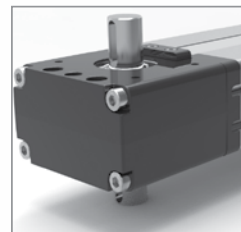

Dual mount "E"  
Doppelwelle "E"  
Doppio albero "E"

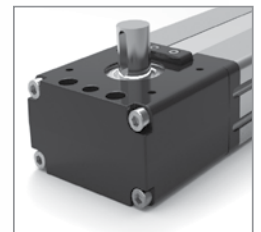

Up mount "D"  
Antriebsswelle oben "D"  
Lato alto "D"

# 18TF42 Series Baureihe 18TF42 | Serie 18TF42

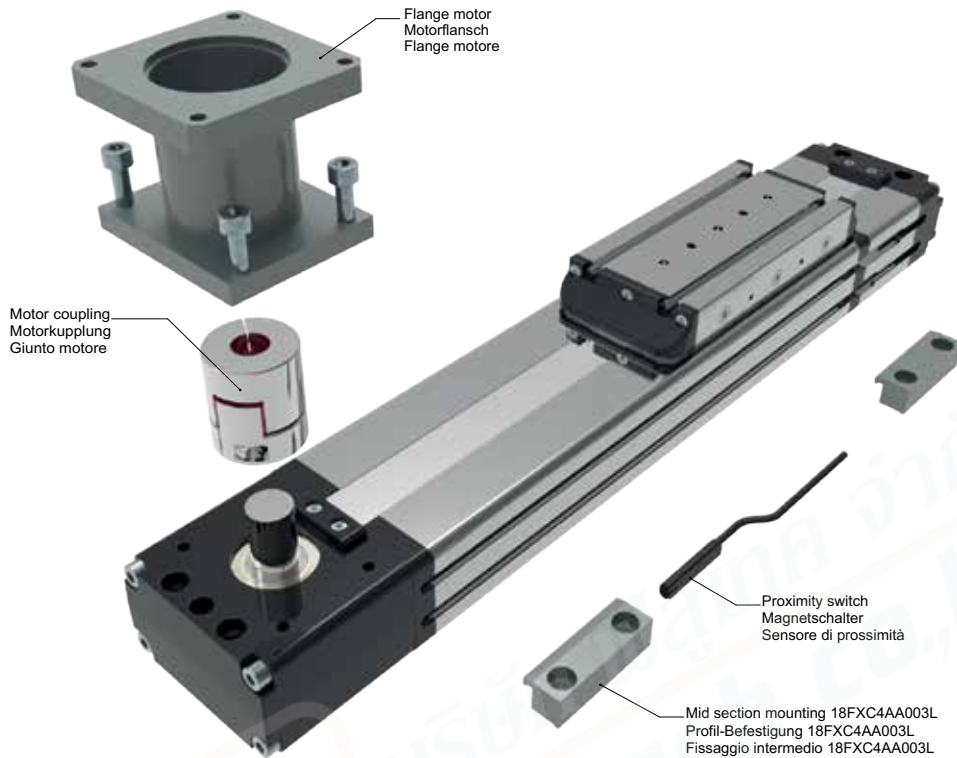

## ORDERING INFORMATION | Bestallangaben Baureihe | Codici per l'ordinazione

### Proximity switch

### Magnetschalter

### Sensore di prossimità

Part nr.   Ident nr.   Cod.	Cable   Kabel   Cavo	Output   Ausgangsfunktion   Uscita
1580.HAP	with 2,5 mt cable - NO   mit 2,5 mt Kabel - NO   con cavo 2,5 mt - NA	PNP, Hall
1580.HAN	with 2,5 mt cable - NO   mit 2,5 mt Kabel - NO   con cavo 2,5 mt - NA	NPN, Hall
MHS.P	300 mm with M8 plug in   mit 300 mm Kabel und M8 Stecker   300 mm conn. M8	PNP, Hall

For the technical characteristics, see the General Catalogue, Section 6 "Magnetic sensors" | Die Eigenschaften von Sensoren sind im allgemeinen Katalog, Abschnitt 6 "magnetische Sensoren dargestellt" | Per le caratteristiche dei sensori, vedi il Catalogo Generale, Sezione 6 "Sensori magnetici"

## 18TF42.0900.A.L

**Stroke mm**  
Hub mm  
Corsa mm

### Version | Version | Versione

L: Single runner block  
Ein Führungswagen  
Pattino guida singolo  
H: Double runner block  
Zwei Führungswagen  
Pattino guida doppio

### Shaft | Versionen Antriebswelle | Versione Albero

- A: Female shaft Ø12 H7 mm with keyshaft  
Hohlwelle mit Ø12 H7 mm und Passfeder  
Albero femmina Ø12 H7 mm con chiavetta
- B: Female shaft Ø14 H7 mm with keyshaft  
Hohlwelle mit Ø14 H7 mm und Passfeder  
Albero femmina Ø14 H7 mm con chiavetta

- C: Male shaft Ø16 h7 mm mount down  
Außenwelle mit Ø16 h7 mm und Wellenposition unten  
Albero maschio uscita Ø16 h7 mm lato sotto
- D: Male shaft Ø16 h7 mm mount up  
Außenwelle mit Ø16 h7 mm und Wellenposition oben  
Albero maschio uscita Ø16 h7 mm lato sopra
- E: Double male shaft Ø16 h7 mm  
Doppelwelle mit Ø16 h7 mm  
Doppio albero maschio Ø16 h7 mm



## 18TF42D Series Baureihe 18TF42D | Serie 18TF42D

### Belt driven guided linear unit

Linearantrieb mit Zahnriemen und integrierter Kugelumlaufführung  
Attuatori lineari a cinghia e guida a ricircolo di sfere

#### TECHNICAL DATA | TECHNISCHE DATEN | DATI TECNICI

Size - Baugröße - Taglia		42x75	
Max. speed - Max. Geschwindigkeit - Velocità max	m/s	3	
Max. stroke length - Max. Hub - Corsa max	mm	6000	
Min. stroke length - Min. Hub - Corsa min	mm	100	
Pulley drive ratio - Hub pro Umdrehung - Corsa/giro puleggia	mm	130	
Number of teeth of pulley - Zähne der Riemenscheibe - nr. denti puleggia		26	
Teeth belt with Steel Reinforced Polyurethane ATL 5 profile clearance 0, width 12 mm ATL 5-Profil Riemen 12 mm Breite 5mm Achsabstand Tipo di cinghia profilo ATL passo 5 larghezza 12 mm			
Max rpm - Max. Drehzahl der Antriebswelle - Max nr. di giri in ingresso	rpm	1400	
runner block - Führungswagen - Pattini guida		H	L
Base weight - Gewicht bei 0mm Hub - Peso corsa 0 mm	Kg	2,8	2,4
Add for 100 mm of stroke - Gewicht bei 100mm Hub - Peso corsa 100 mm	Kg	0,32	0,32
Max. load* - Max. Belastung* - Carico max*	Fx	N	615
	Fy	N	1275
	Fz	N	1275
Moments* - Max. Belastungsmoment*- Momenti max*	Mx	Nm	18
	My	Nm	110
	Mz	Nm	110
Inertia moment Aluminum profile - Flächenträgheitsmoment Momento d'inerzia profilo	Ix	cm4	28
	Iy	cm4	37
Repeatability - Wiederholgenauigkeit - Ripetibilità	mm	± 0,05	
Max. radial load on input shaft - Max. axiallylasten an der Antriebswelle Carico assiale max all'albero motore	N	250	
No load torque - Leerlaufmoment - Coppia resistente	Nm	>0,3	

\* Max values for dynamic conditions. Please refer to the following formula when combined loads are applied.

\* Für die Ermittlung der maximalen dynamischen Tragzahlen bei kombinierten Kraftangriffspunkten, nutzen Sie bitte die nebenstehende Berechnungsformel.

\* Valori massimi in condizioni dinamiche. In presenza di carichi combinati riferirsi alla formula per la verifica dei carichi massimi da applicare.

$$\frac{F_{yA}}{F_y} + \frac{F_{zA}}{F_z} + \frac{M_{xA}}{M_x} + \frac{M_{yA}}{M_y} + \frac{M_{zA}}{M_z} \leq 1$$

The A letters show the calculated value.  
Der A Parameter entspricht dem errechneten Wert.  
La lettera A indica i valori complessivi calcolati

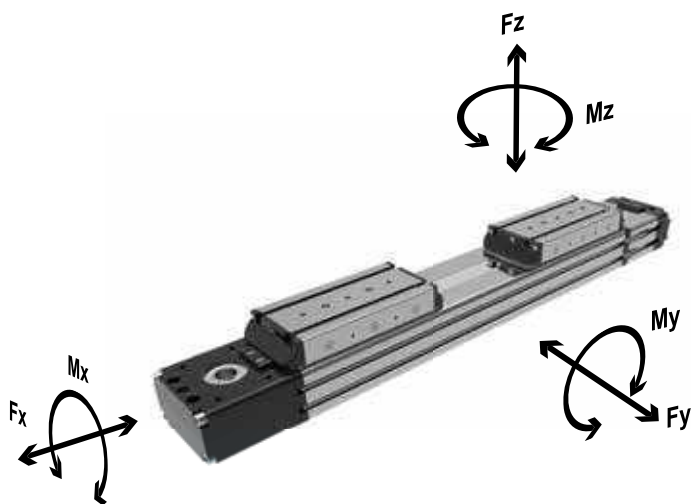





# 18TF42D Series Baureihe 18TF42D | Serie 18TF42D

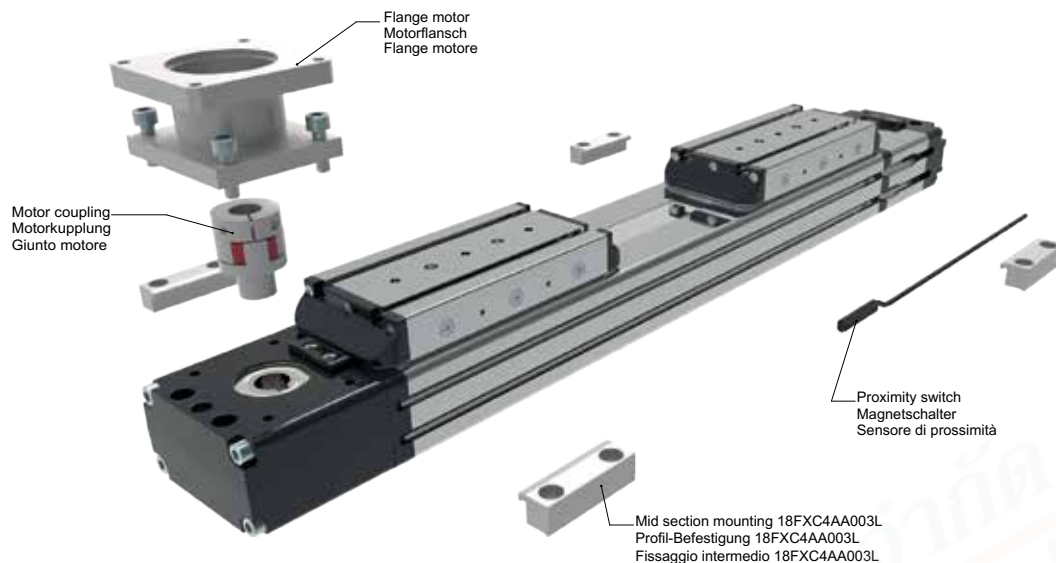

## ORDERING INFORMATION | Bestallangaben Baureihe | Codici per l'ordinazione

### Proximity switch

### Magnetschalter

### Sensore di prossimità

Part nr.   Ident nr.   Cod.	Cable   Kabel   Cavo	Output   Ausgangsfunktion   Uscita
1580.HAP	with 2,5 mt cable - NO   mit 2,5 mt Kabel - NO   con cavo 2,5 mt - NA	PNP, Hall
1580.HAN	with 2,5 mt cable - NO   mit 2,5 mt Kabel - NO   con cavo 2,5 mt - NA	NPN, Hall
MHS.P	300 mm with M8 plug in   mit 300 mm Kabel und M8 Stecker   300 mm conn. M8	PNP, Hall

For the technical characteristics, see the General Catalogue, Section 6 "Magnetic sensors" | Die Eigenschaften von Sensoren sind im allgemeinen Katalog, Abschnitt 6 "magnetische Sensoren dargestellt" | Per le caratteristiche dei sensori, vedi il Catalogo Generale, Sezione 6 "Sensori magnetici"

## 18TF42D.0900.A.L

**Stroke mm**  
Hub mm  
Corsa mm

**Version** | Version | Versione

- L: Single runner block  
Ein Führungswagen  
Pattino guida singolo
- H: Double runner block  
Zwei Führungswagen  
Pattino guida doppio

**Shaft** | Versionen Antriebeswelle | Versione Albero

- A: Female shaft Ø12 H7 mm with keyshaft  
Hohlwelle mit Ø12 H7 mm und Passfeder  
Albero femmina Ø12 H7 mm con chiavetta
- B: Female shaft Ø14 H7 mm with keyshaft  
Hohlwelle mit Ø14 H7 mm und Passfeder  
Albero femmina Ø14 H7 mm con chiavetta

- C: Male shaft Ø16 h7 mm mount down  
Außenwelle mit Ø16 h7 mm und Wellenposition unten  
Albero maschio uscita Ø16 h7 mm lato sotto
- D: Male shaft Ø16 h7 mm mount up  
Außenwelle mit Ø16 h7 mm und Wellenposition oben  
Albero maschio uscita Ø16 h7 mm lato sopra
- E: Double male shaft Ø16 h7 mm  
Doppelwelle mit Ø16 h7 mm  
Doppio albero maschio Ø16 h7 mm

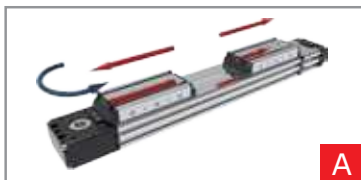

A



B

Picture 1 | Zeichnung 1 | Figura 1

# 18TZ42L Series Baureihe 18TZ42L | Serie 18TZ42L

## Belt driven guided linear unit

Linearantrieb mit Zahnriemen und integrierter Kugelumlauführung  
Attuatori lineari a cinghia e guida a ricircolo di sfere

### TECHNICAL DATA | TECHNISCHE DATEN | DATI TECNICI

Size - Baugröße - Taglia			42x42
Max. speed - Max. Geschwindigkeit - Velocità max	m/s		1
Max. stroke length - Max. Hub - Corsa max	mm		1000
Min. stroke length - Min. Hub - Corsa min	mm		100
Pulley drive ratio - Hub pro Umdrehung - Corsa/giro puleggia	mm		120
Number of teeth of pulley - Zähne der Riemenscheibe - nr. denti puleggia			24
Teeth belt with Steel Reinforced Polyurethane HTD5 profile clearance 0, width 16 mm HTD5-Profil Riemen 16 mm Breite 5 mm Achsabstand Tipo di cinghia profilo HTD5 passo 5 larghezza 16 mm			
Max rpm - Max. Drehzahl der Antriebswelle - Max nr. di giri in ingresso	rpm		500
Base weight - Gewicht bei 0 mm Hub - Peso corsa 0 mm	Kg		1,1
Add for 100 mm of stroke - Gewicht bei 100mm Hub - Peso corsa 100 mm	Kg		0,35
Max. load* - Max. Belastung - Carico max*	Fx	N	600
	Fy	N	1200
	Fz	N	1200
Moments* - Max. Belastungsmoment* - Momenti max*	Mx	Nm	20
	My	Nm	55
	Mz	Nm	55
Inertia moment Aluminum profile - Flächenträgheitsmoment - Momento d'inerzia profilo	Ix	cm <sup>4</sup>	11,8
Inertia moment Aluminum profile - Flächenträgheitsmoment - Momento d'inerzia profilo	Iy	cm <sup>4</sup>	14,2
Repeatability - Wiederholgenauigkeit - Ripetibilità	mm		± 0,1
Max. radial load on input shaft - Max. axiallylasten an der Antriebswelle Carico assiale max all'albero motore	N		200
No load torque - Leerlaufmoment - Coppia resistente	Nm		>0,3

\* Max values for dynamic conditions. Please refer to the following formula when combined loads are applied.

\* Für die Ermittlung der maximalen dynamischen Tragzahlen bei kombinierten Kraftangriffspunkten, nutzen Sie bitte die nebenstehende Berechnungsformel.

\* Valori massimi in condizioni dinamiche. In presenza di carichi combinati riferirsi alla formula per la verifica dei carichi massimi da applicare.

$$\frac{F_{yA}}{F_y} + \frac{F_{zA}}{F_z} + \frac{M_{xA}}{M_x} + \frac{M_{yA}}{M_y} + \frac{M_{zA}}{M_z} \leq 1$$

The A letters show the calculated value.  
Der A Parameter entspricht dem errechneten Wert.  
La lettera A indica i valori complessivi calcolati

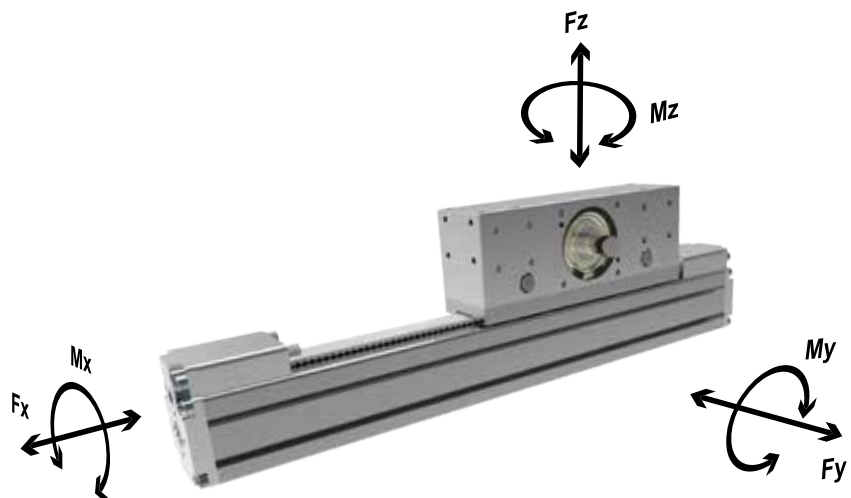



# 18TZ42L Series Baureihe 18TZ42L | Serie 18TZ42L

ELECTRIC ACTUATION - ELEKTRISCHE ANTRIEBE - ATTUAZIONE ELETTRICA

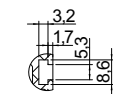
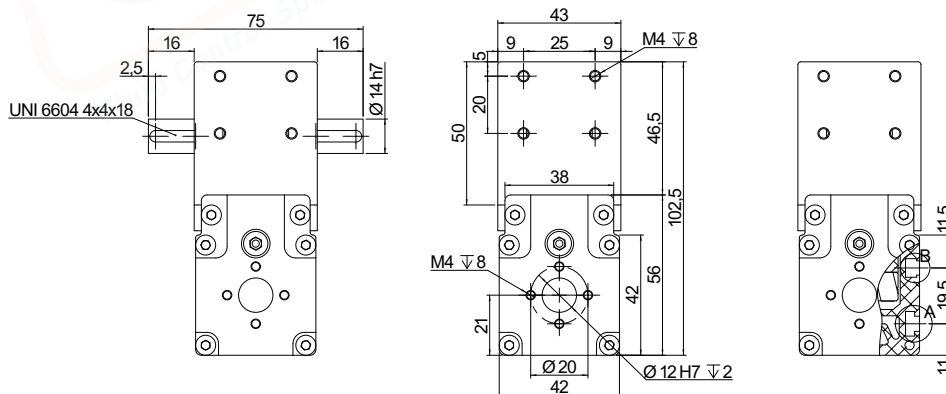
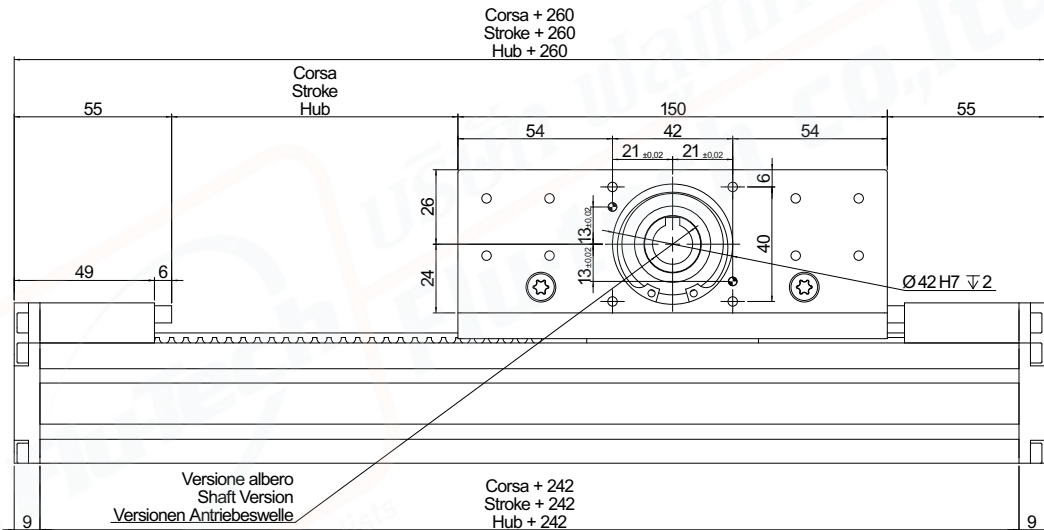
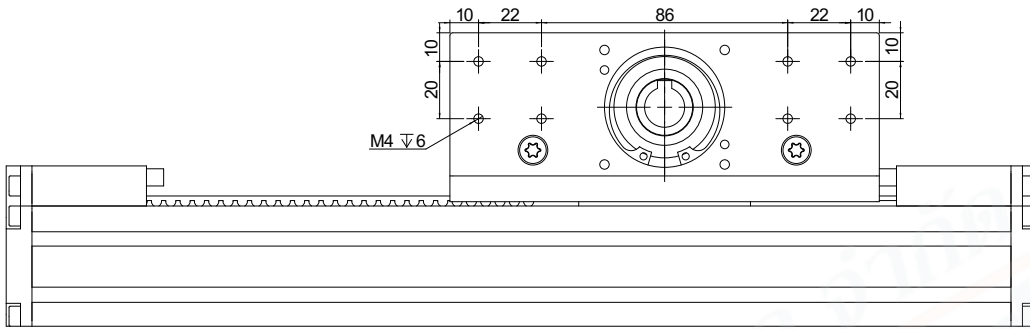
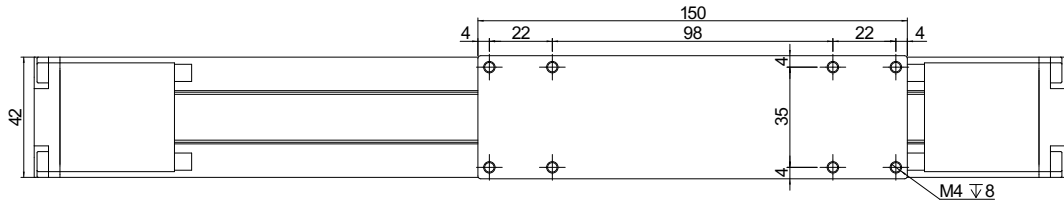

Vista A  
View A  
Ansicht A



Vista B  
View B  
Ansicht B

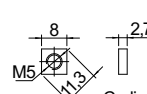

Codice: 18FXDQM0501  
Part. n: 18FXDQM0501  
Bestellcode: 18FXDQM0501

# 18TZ42L Series Baureihe 18TZ42L | Serie 18TZ42L

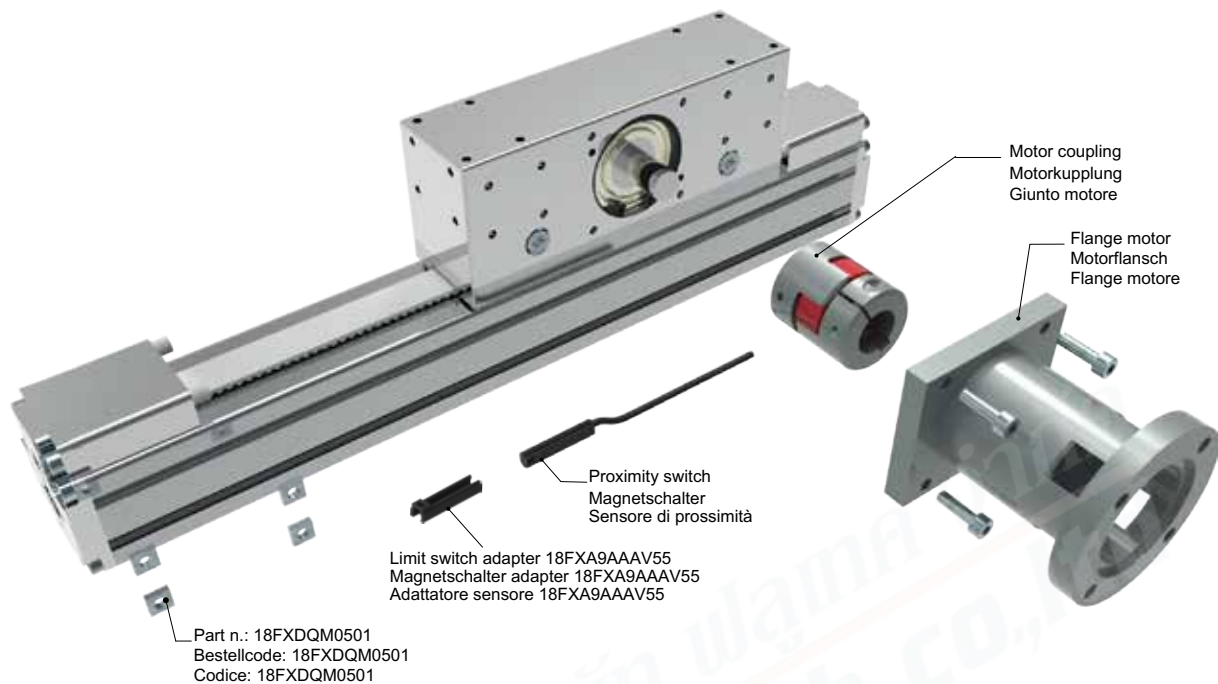

## ORDERING INFORMATION | Bestallangaben Baureihe | Codici per l'ordinazione

Proximity switch		Magnetschalter	Sensore di prossimità
Part nr.   Ident nr.   Cod.	Cable   Kabel   Cavo	Output   Ausgangfunktion   Uscita	
1581.HAP	with 2,5 mt cable - NO   mit 2,5 mt Kabel - NO   con cavo 2,5 mt - NA	PNP, Hall	
THS.P	100 mm with M8 plug in   mit 100 mm Kabel und M8 Stecker   100 mm conn. M8	PNP, Hall	

For the technical characteristics, see the General Catalogue, Section 6 "Magnetic sensors" | Die Eigenschaften von Sensoren sind im allgemeinen Katalog, Abschnitt 6 "magnetische Sensoren dargestellt" | Per le caratteristiche dei sensori, vedi il Catalogo Generale, Sezione 6 "Sensori magnetici"

## 18TZ42L.0900.A

**Stroke mm**  
Hub mm  
Corsa mm

### Shaft | Versionen Antriebeswelle | Versione Albero

- A: Female shaft Ø14 mm with keyshaft  
Hohlwelle mit Ø14 mm und Passfeder  
Albero femmina Ø14 mm con chiavetta
- B: Male shaft Ø14 mm  
Außenwelle mit Ø14 mm  
Albero maschio uscita Ø14



# 18TZ55L Series Baureihe 18TZ55L | Serie 18TZ55L

## Belt driven guided linear unit

Linearantrieb mit Zahnriemen und integrierter Kugelumlaufführung  
Attuatori lineari a cinghia e guida a ricircolo di sfere

### TECHNICAL DATA | TECHNISCHE DATEN | DATI TECNICI

Size - Baugröße - Taglia			55X55
Max. speed - Max. Geschwindigkeit - Velocità max	m/s		1
Max. stroke length - Max. Hub - Corsa max	mm		1500
Min. stroke length - Min. Hub - Corsa min	mm		100
Pulley drive ratio - Hub pro Umdrehung - Corsa/giro puleggia	mm		130
Number of teeth of pulley - Zähne der Riemenscheibe - nr. denti puleggia			26
Teeth belt with Steel Reinforced Polyurethane HTD5 profile clearance 0, width 25 mm HTD5-Profil Riemen 26 mm Breite 5 mm Achsabstand Tipo di cinghia profilo HTD5 passo 5 larghezza 25 mm			
Max rpm - Max. Drehzahl der Antriebswelle - Max nr. di giri in ingresso	rpm		750
Base weight - Gewicht bei 0 mm Hub - Peso corsa 0 mm	Kg		3,7
Add for 100 mm of stroke - Gewicht bei 100mm Hub - Peso corsa 100 mm	Kg		0,52
Max. load* - Max. Belastung* - Carico max*	Fx	N	1250
	Fy	N	3000
	Fz	N	3000
Moments* - Max. Belastungsmoment* - Momenti max*	Mx	Nm	45
	My	Nm	220
	Mz	Nm	220
Inertia moment Aluminum profile - Flächenträgheitmoment - Momento d'inerzia profilo	Ix	cm4	36
	Iy	cm4	45
Repeatability - Wiederholgenauigkeit - Ripetibilità	mm		± 0,1
Max. radial load on input shaft - Max. axiallylasten an der Antriebswelle Carico assiale max all'albero motore	N		2300
No load torque - Leerlaufmoment - Coppia resistente	Nm		>0,7

\*\* Max values for dynamic conditions. Please refer to the following formula when combined loads are applied.

\*\* Für die Ermittlung der maximalen dynamischen Tragzahlen bei kombinierten Kraftangriffspunkten, nutzen Sie bitte die nebenstehende Berechnungsformel.

\*\* Valori massimi in condizioni dinamiche. In presenza di carichi combinati riferirsi alla formula per la verifica dei carichi massimi da applicare.

$$\frac{F_{yA}}{F_y} + \frac{F_{zA}}{F_z} + \frac{M_{xA}}{M_x} + \frac{M_{yA}}{M_y} + \frac{M_{zA}}{M_z} \leq 1$$

The A letters show the calculated value.  
Der A Parameter entspricht dem errechneten Wert.  
La lettera A indica i valori complessivi calcolati

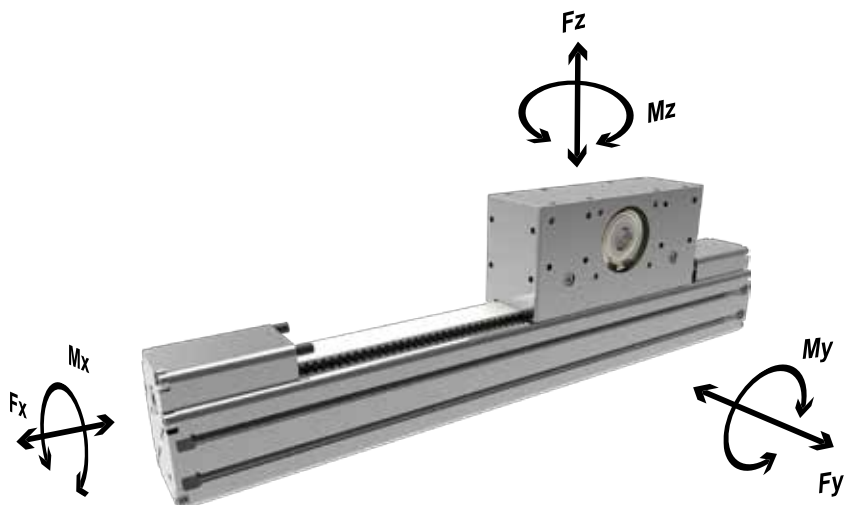





# 18TZ55L Series Baureihe 18TZ55L | Serie 18TZ55L

ELECTRIC ACTUATION - ELEKTRISCHE ANTRIEBE - ATTUAZIONE ELETTRICA

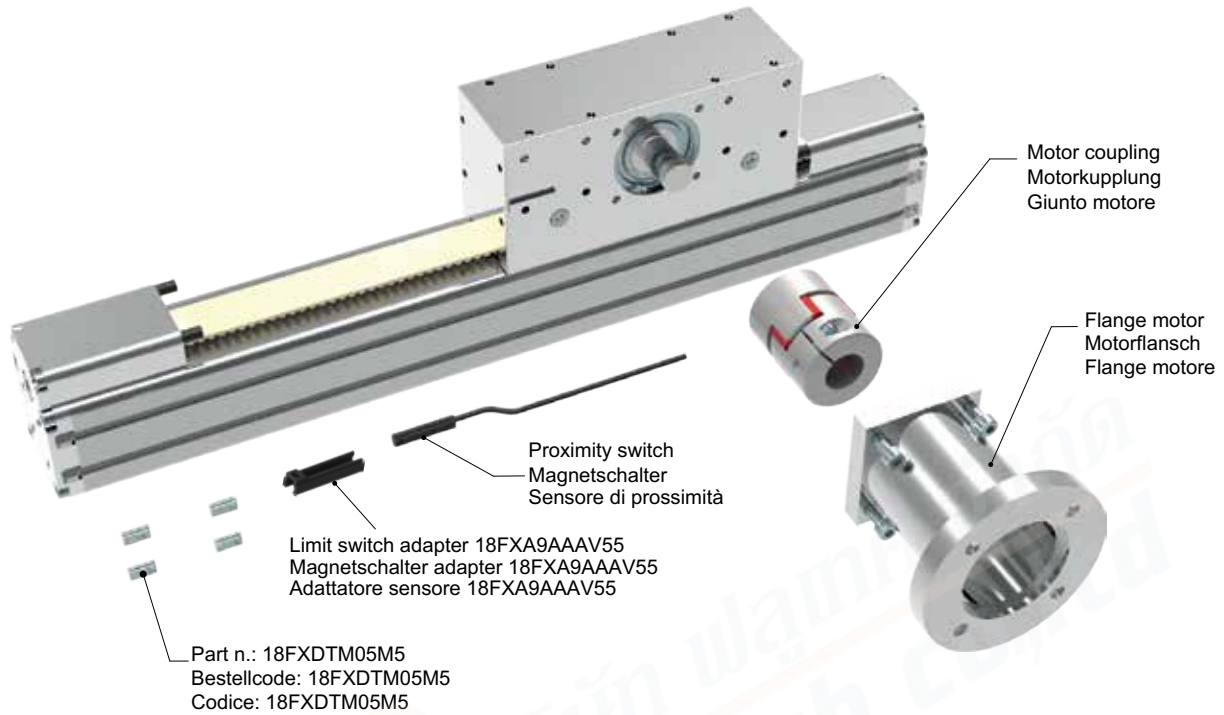

## ORDERING INFORMATION | Bestallangaben Baureihe | Codici per l'ordinazione

Proximity switch		Magnetschalter	Sensore di prossimità
Part nr.   Ident nr.   Cod.	Cable   Kabel   Cavo	Output   Ausgangsfunktion   Uscita	
1581.HAP	with 2,5 mt cable - NO   mit 2,5 mt Kabel - NO   con cavo 2,5 mt - NA	PNP, Hall	
THS.P	100 mm with M8 plug in   mit 100 mm Kabel und M8 Stecker   100 mm conn. M8	PNP, Hall	

For the technical characteristics, see the General Catalogue, Section 6 "Magnetic sensors" | Die Eigenschaften von Sensoren sind im allgemeinen Katalog, Abschnitt 6 "magnetische Sensoren dargestellt" | Per le caratteristiche dei sensori, vedi il Catalogo Generale, Sezione 6 "Sensori magnetici"

## 18TZ55L.0900.A

**Stroke mm**  
Hub mm  
Corsa mm

**Shaft** | Versionen Antriebeswelle | Versione Albero

- A: Female shaft Ø16 mm with keyshaft  
Hohlwelle mit Ø16 mm und Passfeder  
Albero femmina Ø16 mm con chiavetta
- B: Male shaft Ø16 mm  
Außenwelle mit Ø16 mm  
Albero maschio uscita Ø16

# 18TZ80L Series Baureihe 18TZ80L | Serie 18TZ80L

## Belt driven guided linear unit

Linearantrieb mit Zahnriemen und integrierter Kugelumlaufführung  
Attuatori lineari a cinghia e guida a ricircolo di sfere

### TECHNICAL DATA | TECHNISCHE DATEN | DATI TECNICI

Size - Baugröße - Taglia			80X80
Max. speed - Max. Geschwindigkeit - Velocità max	m/s		1
Max. stroke length - Max. Hub - Corsa max	mm		1500
Min. stroke length - Min. Hub - Corsa min	mm		100
Pulley drive ratio - Hub pro Umdrehung - Corsa/giro puleggia	mm		192
Number of teeth of pulley - Zähne der Riemenscheibe - nr. denti puleggia			24
Teeth belt with Steel Reinforced Polyurethane HTD8 profile clearance 0, width 30 mm HTD8-Profil Riemen 30 mm Breite - 8 mm Achsabstand Tipo di cinghia profilo HTD passo 8 larghezza 30 mm			
Max rpm - Max. Drehzahl der Antriebswelle - Max nr. di giri in ingresso	rpm		900
Base weight - Gewicht bei 0 mm Hub - Peso corsa 0 mm	Kg		12
Add for 100 mm of stroke - Gewicht bei 100mm Hub - Peso corsa 100 mm	Kg		0,9
Max. load* - Max. Belastung - Carico max*	Fx	N	2500
	Fy	N	4500
	Fz	N	4500
Moments* - Max. Belastungsmoment* - Momenti max*	Mx	Nm	90
	My	Nm	390
	Mz	Nm	390
Inertia moment Aluminum profile - Flächenträgheitsmoment - Momento d'inerzia profilo	Ix	cm <sup>4</sup>	183
Inertia moment Aluminum profile - Flächenträgheitsmoment - Momento d'inerzia profilo	Iy	cm <sup>4</sup>	226
Repeatability - Wiederholgenauigkeit - Ripetibilità	mm		± 0,1
Max. radial load on input shaft - Max. axiallylasten an der Antriebswelle Carico assiale max all'albero motore	N		300
No load torque - Leerlaufmoment - Coppia resistente	Nm		>0,6

\* Max values for dynamic conditions. Please refer to the following formula when combined loads are applied.

\* Für die Ermittlung der maximalen dynamischen Tragzahlen bei kombinierten Kraftangriffspunkten, nutzen Sie bitte die nebenstehende Berechnungsformel.

\* Valori massimi in condizioni dinamiche. In presenza di carichi combinati riferirsi alla formula per la verifica dei carichi massimi da applicare.

$$\frac{F_{yA}}{F_y} + \frac{F_{zA}}{F_z} + \frac{M_{xA}}{M_x} + \frac{M_{yA}}{M_y} + \frac{M_{zA}}{M_z} \leq 1$$

The A letters show the calculated value.  
Der A Parameter entspricht dem errechneten Wert.  
La lettera A indica i valori complessivi calcolati

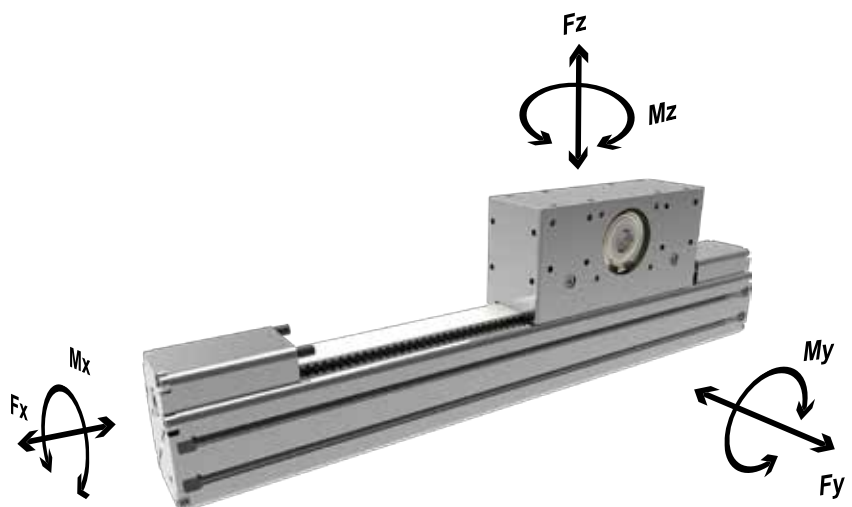



# 18TZ80L Series Baureihe 18TZ80L | Serie 18TZ80L

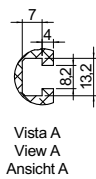
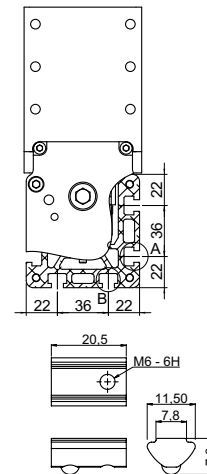
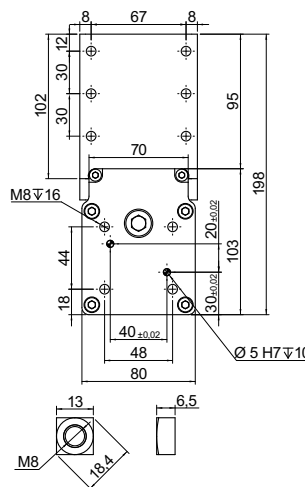
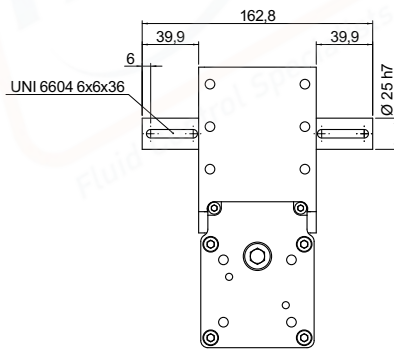
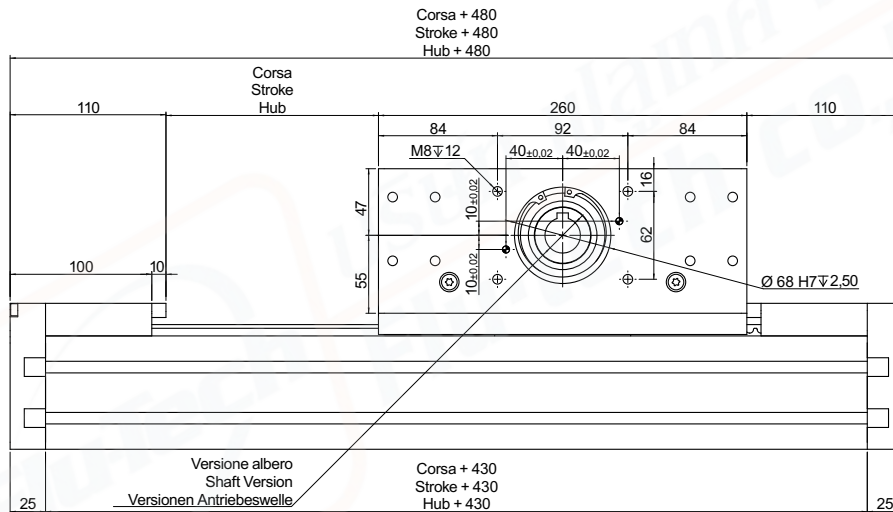
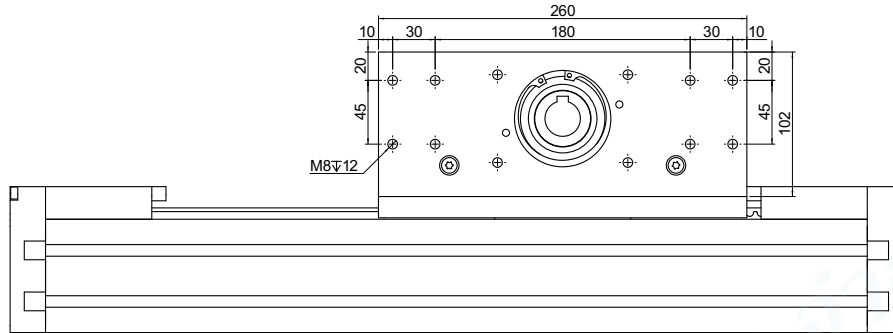
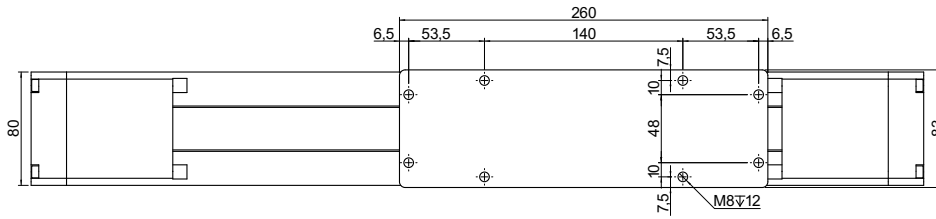

Codice: 18FXDQM08  
Part.n: 18FXDQM08  
Bestellcode: 18FXDQM08

Codice: 18FXDTM08M6  
Part.n: 18FXDTM08M6  
Bestellcode: 18FXDTM08M6

ELECTRIC ACTUATION - ELEKTRISCHE ANTRIEBE - ATTUAZIONE ELETTRICA

# 18TZ80L Series Baureihe 18TZ80L | Serie 18TZ80L

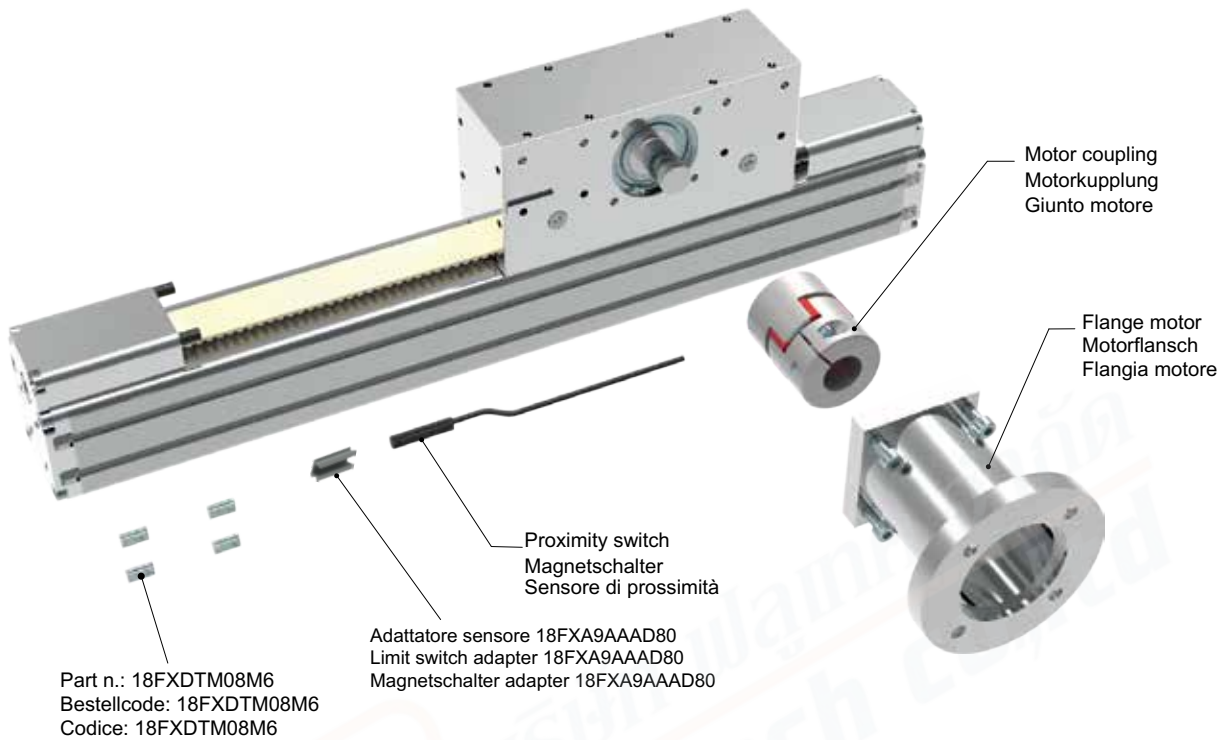

## ORDERING INFORMATION | Bestallangaben Baureihe | Codici per l'ordinazione

Proximity switch		Magnetschalter	Sensore di prossimità
Part nr.   Ident nr.   Cod.	Cable   Kabel   Cavo	Output   Ausgangsfunktion   Uscita	
1580.HAP	with 2,5 mt cable - NO   mit 2,5 mt Kabel - NO   con cavo 2,5 mt - NA	PNP, Hall	
1580.HAN	with 2,5 mt cable - NO   mit 2,5 mt Kabel - NO   con cavo 2,5 mt - NA	NPN, Hall	
MHS.P	300 mm with M8 plug in   mit 300 mm Kabel und M8 Stecker   300 mm conn. M8	PNP, Hall	

For the technical characteristics, see the General Catalogue, Section 6 "Magnetic sensors" | Die Eigenschaften von Sensoren sind im allgemeinen Katalog, Abschnitt 6 "magnetische Sensoren dargestellt" | Per le caratteristiche dei sensori, vedi il Catalogo Generale, Sezione 6 "Sensori magnetici"

## 18TZ80L - 0900 - A

Stroke mm  
Hub mm  
Corsa mm

Shaft | Versionen Antriebeswelle | Versione Albero

- A: Female shaft Ø25 mm with keyshaft  
Hohlwelle mit Ø25 mm und Passfeder  
Albero femmina Ø25 mm con chiavetta
- B: Male shaft Ø25 mm  
Außenwelle mit Ø25 mm  
Albero maschio uscita Ø25



# 18TZ55S Series Baureihe 18TZ55S | Serie 18TZ55S

## Belt driven guided linear unit

Linearantrieb mit Zahnriemen und integrierter Kugelumlaufführung  
Attuatori lineari a cinghia e guida a ricircolo di sfere

### TECHNICAL DATA | TECHNISCHE DATEN | DATI TECNICI

Size - Baugröße - Taglia			55X55
Max. speed - Max. Geschwindigkeit - Velocità max	m/s		1
Max. stroke length - Max. Hub - Corsa max	mm		1500*
Min. stroke length - Min. Hub - Corsa min	mm		100
Pulley drive ratio - Hub pro Umdrehung - Corsa/giro puleggia	mm		130
Number of teeth of pulley - Zähne der Riemenscheibe - nr. denti puleggia			26
Teeth belt with Steel Reinforced Polyurethane HTD5 profile clearance 0, width 25 mm HTD5-Profil Riemen 26 mm Breite - 5 mm Achsabstand Tipo di cinghia profilo HTD5 passo 5 larghezza 25 mm			
Max rpm - Max. Drehzahl der Antriebswelle - Max nr. di giri in ingresso	rpm		500
Base weight - Gewicht bei 0 mm Hub - Peso corsa 0 mm	Kg		5,1
Add for 100 mm of stroke - Gewicht bei 100mm Hub - Peso corsa 100 mm	Kg		0,6
Max. load* - Max. Belastung - Carico max*	Fx	N	1250
	Fy	N	7800
	Fz	N	7800
Moments* - Max. Belastungsmoment* - Momenti max*	Mx	Nm	395
	My	Nm	480
	Mz	Nm	480
Inertia moment Aluminum profile - Flächenträgheitsmoment - Momento d'inerzia profilo	Ix	cm <sup>4</sup>	36
	Iy	cm <sup>4</sup>	45
Repeatability - Wiederholgenauigkeit - Ripetibilità	mm		± 0,1
Max. radial load on input shaft - Max. axillasten an der Antriebswelle Carico assiale max all'albero motore		N	300
	No load torque - Leerlaufmoment - Coppia resistente	Nm	>0,7

\* Max values for dynamic conditions. Please refer to the following formula when combined loads are applied.

\* Für die Ermittlung der maximalen dynamischen Tragzahlen bei kombinierten Kraftangriffspunkten, nutzen Sie bitte die nebenstehende Berechnungsformel.

\* Valori massimi in condizioni dinamiche. In presenza di carichi combinati riferirsi alla formula per la verifica dei carichi massimi da applicare.

$$\frac{F_{yA}}{F_y} + \frac{F_{zA}}{F_z} + \frac{M_{xA}}{M_x} + \frac{M_{yA}}{M_y} + \frac{M_{zA}}{M_z} \leq 1$$

The A letters show the calculated value.  
Der A Parameter entspricht dem errechneten Wert.  
La lettera A indica i valori complessivi calcolati

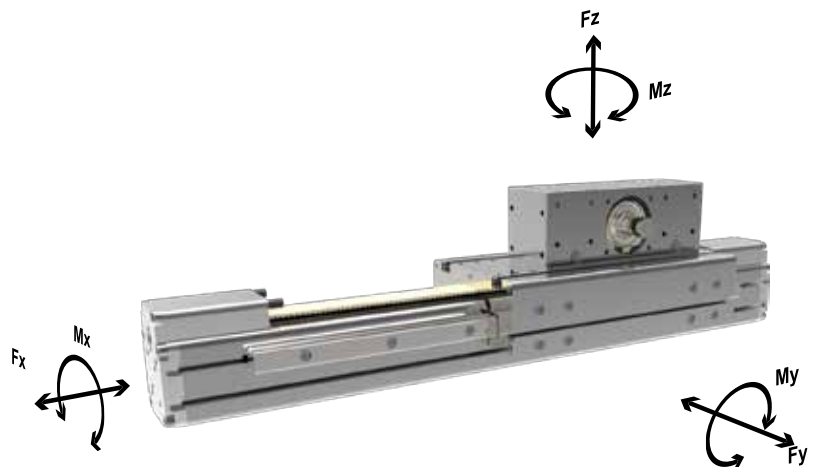





## 18TZ55S Series Baureihe 18TZ55S | Serie 18TZ55S

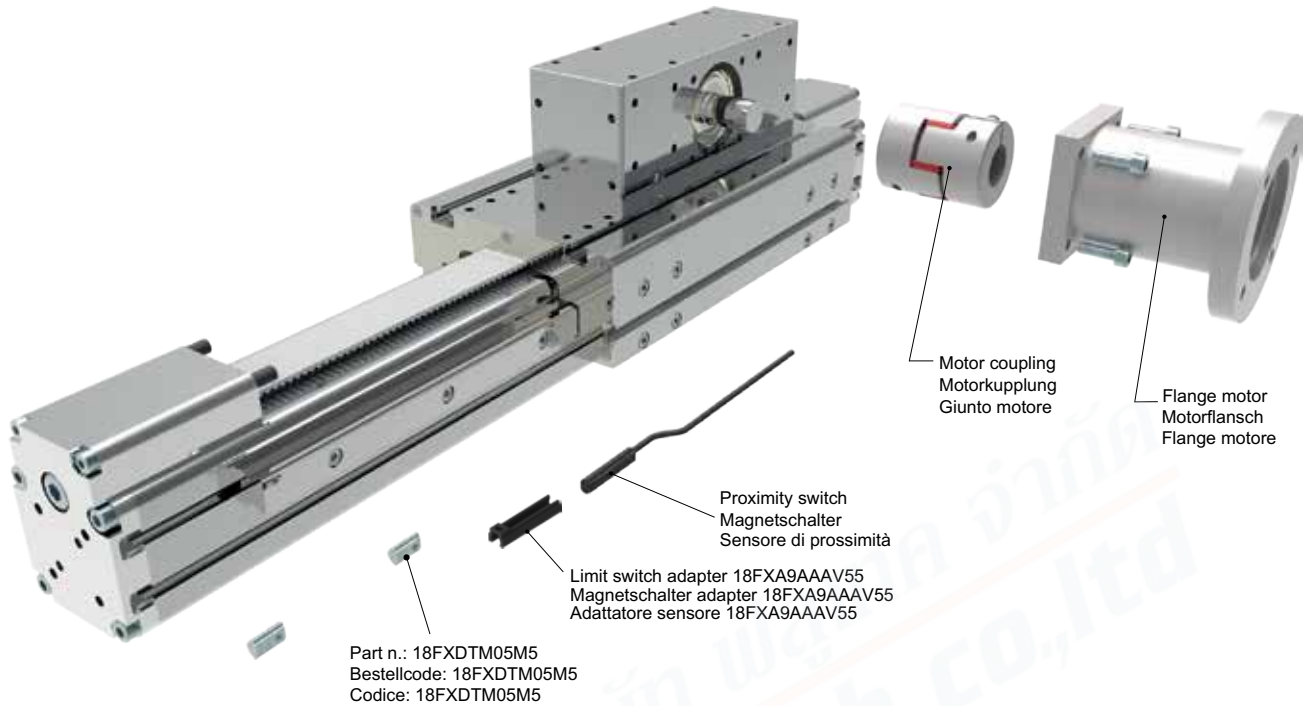

### ORDERING INFORMATION | Bestallangaben Baureihe | Codici per l'ordinazione

Proximity switch		Magnetschalter	Sensore di prossimità
Part nr.   Ident nr.   Cod.	Cable   Kabel   Cavo	Output   Ausgangsfunktion   Uscita	
1581.HAP	with 2,5 mt cable - NO   mit 2,5 mt Kabel - NO   con cavo 2,5 mt - NA	PNP, Hall	
THS.P	100 mm with M8 plug in   mit 100 mm Kabel und M8 Stecker   100 mm conn. M8	PNP, Hall	

For the technical characteristics, see the General Catalogue, Section 6 "Magnetic sensors" | Die Eigenschaften von Sensoren sind im allgemeinen Katalog, Abschnitt 6 "magnetische Sensoren dargestellt" | Per le caratteristiche dei sensori, vedi il Catalogo Generale, Sezione 6 "Sensori magnetici"

## 18TZ55S.0900.A

**Stroke mm**  
Hub mm  
Corsa mm

### Shaft | Versionen Antriebeswelle | Versione Albero

- A: Female shaft Ø16 mm with keyshaft  
Hohlwelle mit Ø16 mm und Passfeder  
Albero femmina Ø16 mm con chiavetta
- B: Male shaft Ø16 mm mount left  
Außenwelle mit Ø16 mm und Wellenposition rechts  
Albero maschio uscita Ø16 mm lato sinistro
- C: Male shaft Ø16 mm mount right  
Außenwelle mit Ø16 mm und Wellenposition links  
Albero maschio uscita Ø16 mm lato destro
- D: Double male shaft Ø16 mm  
Doppelwelle mit Ø16 mm  
Doppio albero maschio Ø16 mm

# 18TZ80S Series Baureihe 18TZ80S | Serie 18TZ80S

## Belt driven guided linear unit

Linearantrieb mit Zahnriemen und integrierter Kugelumlaufführung  
Attuatori lineari a cinghia e guida a ricircolo di sfere

TECHNICAL DATA   TECHNISCHE DATEN   DATI TECNICI			
Size - Baugröße - Taglia			80x80
Max. speed - Max. Geschwindigkeit - Velocità max	m/s		2
Max. stroke length - Max. Hub - Corsa max	mm		1500
Min. stroke length - Min. Hub - Corsa min	mm		100
Pulley drive ratio - Hub pro Umdrehung - Corsa/giro puleggia	mm		192
Number of teeth of pulley - Zähne der Riemenscheibe - nr. denti puleggia			24
Teeth belt with Steel Reinforced Polyurethane HTD8 profile clearance 0, width 30 mm HTD8 Profil Riemen 30 mm Breite 8mm Achsabstand Tipo di cinghia profilo HTD8 passo 8 larghezza 30 mm			
Max rpm - Max. Drehzahl der Antriebswelle - Max nr. di giri in ingresso	rpm		900
Base weight - Gewicht bei 0mm Hub - Peso corsa 0 mm	Kg		15
Add for 100 mm of stroke - Gewicht bei 100mm Hub - Peso corsa 100 mm	Kg		1,55
Max. load* - Max. Belastung - Carico max*	Fx	N	2500
	Fy	N	4500
	Fz	N	4500
Moments* - Max. Belastungsmoment* - Momenti max*	Mx	Nm	620
	My	Nm	980
	Mz	Nm	980
Inertia moment Aluminum profile - Flächenträgheitsmoment - Momento d'inerzia profilo	Ix	cm4	183
	Iy	cm4	226
Repeatability - Wiederholgenauigkeit - Ripetibilità	mm		± 0,05
Max. radial load on input shaft - Max. axiallasten an der Antriebswelle Carico assiale max all'albero motore		N	300
	No load torque - Leerlaufmoment - Coppia resistente		Nm

\* Max values for dynamic conditions. Please refer to the following formula when combined loads are applied.

\* Für die Ermittlung der maximalen dynamischen Tragzahlen bei kombinierten Kraftangriffspunkten, nutzen Sie bitte die nebenstehende Berechnungsformel.

\* Valori massimi in condizioni dinamiche. In presenza di carichi combinati riferirsi alla formula per la verifica dei carichi massimi da applicare.

$$\frac{F_{yA}}{F_y} + \frac{F_{zA}}{F_z} + \frac{M_{xA}}{M_x} + \frac{M_{yA}}{M_y} + \frac{M_{zA}}{M_z} \leq 1$$

The A letters show the calculated value.  
Der A Parameter entspricht dem errechneten Wert.  
La lettera A indica i valori complessivi calcolati

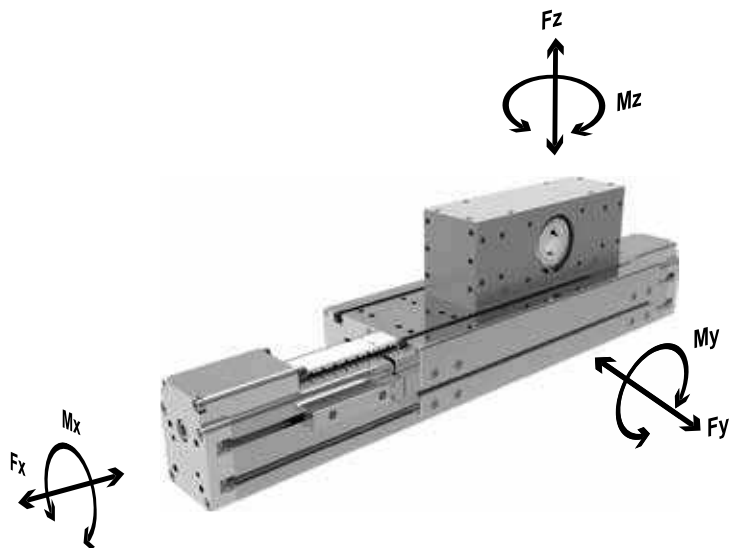



# 18TZ80S Series Baureihe 18TZ80S | Serie 18TZ80S

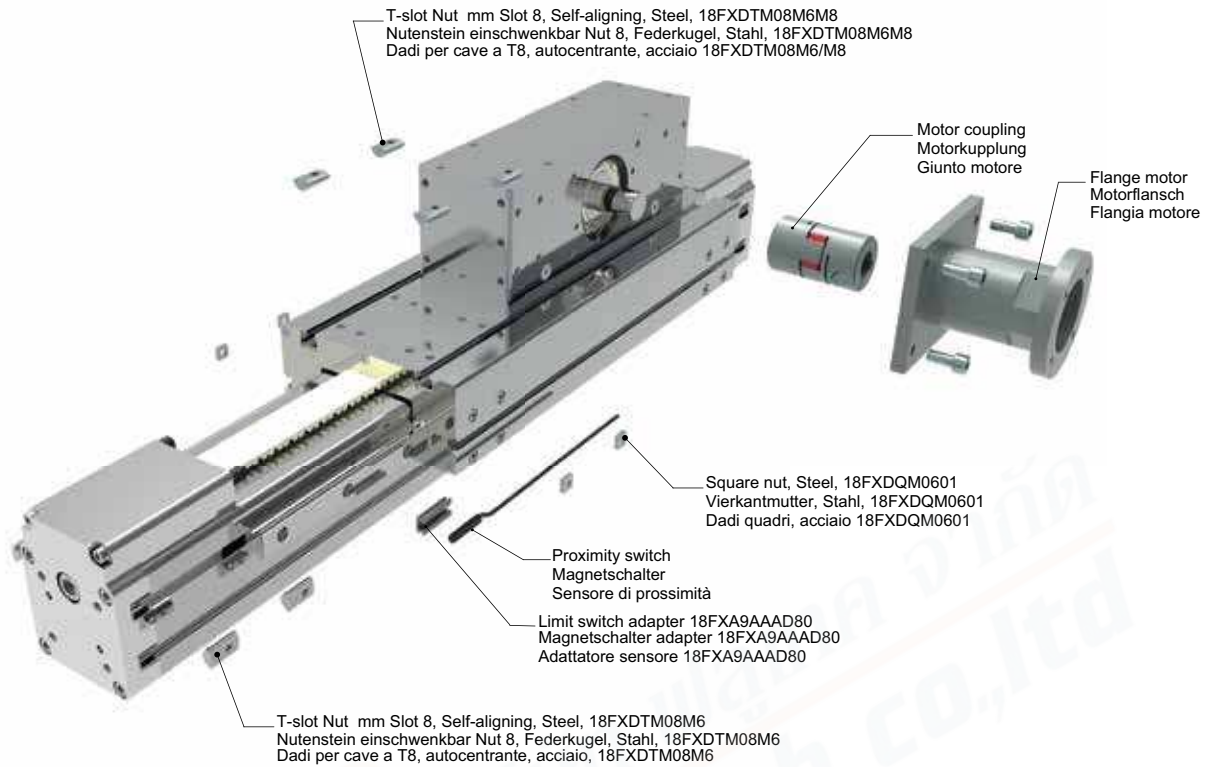

## ORDERING INFORMATION | Bestallangaben Baureihe | Codici per l'ordinazione

Proximity switch		Magnetschalter	Sensore di prossimità
Part nr.   Ident nr.   Cod.	Cable   Kabel   Cavo	Output   Ausgangsfunktion   Uscita	
1580.HAP	with 2,5 mt cable - NO   mit 2,5 mt Kabel - NO   con cavo 2,5 mt - NA	PNP, Hall	
1580.HAN	with 2,5 mt cable - NO   mit 2,5 mt Kabel - NO   con cavo 2,5 mt - NA	NPN, Hall	
MHS.P	300 mm with M8 plug in   mit 300 mm Kabel und M8 Stecker   300 mm conn. M8	PNP, Hall	

For the technical characteristics, see the General Catalogue, Section 6 "Magnetic sensors" | Die Eigenschaften von Sensoren sind im allgemeinen Katalog, Abschnitt 6 "magnetische Sensoren dargestellt" | Per le caratteristiche dei sensori, vedi il Catalogo Generale, Sezione 6 "Sensori magnetici"

## 18TZ80S - 0900 - A

Stroke mm  
Hub mm  
Corsa mm

Shaft | Versionen Antriebeswelle | Versione Albero

- A: Female shaft Ø25 mm with keyshaft  
Hohlwelle mit Ø25 mm und Passfeder  
Albero femmina Ø25 mm con chiavetta
- B: Male shaft Ø25 mm mount left  
Außenwelle mit Ø25 mm und Wellenposition rechts  
Albero maschio uscita Ø25 mm lato sinistro
- C: Male shaft Ø25 mm mount right  
Außenwelle mit Ø25 mm und Wellenposition links  
Albero maschio uscita Ø25 mm lato destro

## Ball screw linear actuator

### Linearaktuatoren mit Kugelgewindetrieb

### Attuatori lineari - trasmissione a ricircolo di sfere

18TV Series	Baureihe 18TV	Serie 18TV
<p>Transmission with ball screw. "T" slot for actuator fixing, "T" slot for proximity switch Ball rail system. Sealed against pollution. Carriage in aluminium anodized with "T" slot. Motor mount assembly available with male shaft.</p>	<p>Linearaktuator, erhältlich in 3 Baugrößen. Antrieb über Kugelgewindetrieb. Profil aus eloxiertem Aluminium mit T-Nuten zur Befestigung der Achse und Montage der Positionssensoren entlang des Aktuators. Integrierte Kugelumlauflührung. Schutz vor eindringendem Schmutz durch Abdeckband aus gehärtetem Edelstahl und Abstreifern am Laufwagen. Laufwagen aus eloxiertem Aluminium mit T-Nuten zur Befestigung der Last. Motorbefestigung mit Außenwelle.</p>	<p>Attuatore lineare disponibile in 3 taglie. Trasmissione con vite a ricircolo di sfere. Profilato in alluminio anodizzato con cave a "T" per fissaggio dell'asse e montaggio dei sensori di posizione lungo l'attuatore. Guida a ricircolo di sfere intergata. Protezione dalle impurità esterne con bandella in acciaio inox temprato ed elementi a strisciamento sul carrello esterno. Carrello esterno in alluminio anodizzato con cave a T per il fissaggio del carico. Fissaggio motore con albero maschio.</p>
18VS Series	Baureihe 18VS	Serie 18VS
<p>Linear actuator available in 2 sizes, this is a variant of 18TV version, which includes 2 outer ball recirculating guides attached to the profile, which increases the loads and moments applicable to the actuator.</p>	<p>Linearaktuator, erhältlich in 2 Baugrößen, verfügt im Unterschied zur Version 18TV über 2 am Profil befestigte Kugelumlauflührungen, was eine noch höhere Last- und Momentenaufnahme ermöglicht.</p>	<p>Attuatore lineare disponibile in 2 taglie, variante della versione 18TV, con 2 guide a ricircolo di sfere esterne fissate al profilato, per un incremento ulteriore di carichi e momenti applicabili all'attuatore.</p>
18UK Series	Baureihe 18UK	Serie 18UK
<p>Linear actuator with compact dimensions. Transmission with ball screw. The load should be fixed to the external supports in their own channel, covered by hardened stainless steel strips, kept clean of external debris by using wipers on the heads. Anodized aluminum profile with shaft fixing holes and the ability to mount sensors along the length of the actuator. Ball rail system. Motor mount assembly available with male shaft.</p>	<p>Linearaktuator in kompakter Bauweise mit geringem Platzbedarf. Antrieb über Kugelgewindetrieb. Die Last muss an den externen, in ihren Nuten gleitenden Trägern befestigt werden. Die Nuten werden durch Abdeckbänder aus gehärtetem Edelstahl verschlossen und durch Abstreifer an den Stirnseiten vor eindringendem Schmutz geschützt. en zur Befestigung der Achse und Montage der Positionssensoren entlang des Aktuators. Integrierte Kugelumlauflührung. Motorbefestigung mit Außenwelle.</p>	<p>Attuatore lineare ad ingombro contenuto e compatto. Trasmissione con vite a ricircolo di sfere. Il carico va fissato ai supporti esterni che scorrono nelle proprie cave, chiuse da bandelle in acciaio inox temprato, tenute pulite dalle impurità esterne attraverso elementi striscianti posti sulle testate. Profilato in alluminio anodizzato con cave per fissaggio dell'asse e montaggio dei sensori di posizione lungo l'attuatore. Guida a ricircolo di sfere intergata. Fissaggio motore con albero maschio.</p>
18TL Series	Baureihe 18TL	Serie 18TL
<p>Linear unit with screw and ball recirculation guides for heavy load applications. The wide and low profile provide a rigid unit suitable for applications where precision, high load capacity and bending moments are required. Available in 2 sizes, the unit consists of 2 ball recirculating guides with 4 balls and ball screws. The carriage provides a wide support surface with protective bellows, integrated position sensor and male motor mounting.</p>	<p>Lineareinheit mit Spindel und Kugelumlauflührungen für Anwendungen mit schweren Lasten. Durch das breite und niedrige Profil verfügt die Lineareinheit über eine hohe Steifigkeit und eignet sich für Anwendungen, in denen Präzision und hohe Lastkapazitäten und Biegemomente gefordert sind. Erhältlich in 2 Baugrößen. Bestehend aus 2 Kugelumlauflührungen mit 4 Schlitten und Kugelgewindetrieb. Der Laufwagen bietet eine große Aufnahmefläche. Schutzbalge und integrierte Positionssensoren. Motorbefestigung mit Außenwelle.</p>	<p>Unità lineare con vite e guide a ricircolo di sfere per applicazioni con carichi pesanti. Il profilo largo e basso permette di avere un'unità rigida adatta per applicazioni dove sono richieste precisione, alta capacità di carico e ai momenti flettenti. Disponibili in 2 taglie. sono composte da 2 guide a ricircolo di sfere con 4 pattini e vite a ricircolo di sfere. Il carrello offre un'ampia superficie di appoggio. soffiotti di protezione e sensori di posizione integrati. fissaggio motore maschio.</p>



## 18TV42 Series Baureihe 18TV42 | Serie 18TV42

### Screw driven guided linear unit

Linearantrieb mit Rundspindel und integrierter Kugelumlauführung  
Attuatori lineari a vite e guida a ricircolo di sfere

#### TECHNICAL DATA | TECHNISCHE DATEN | DATI TECNICI

Size - Baugröße - Taglia			42x45	
Max. speed* - Max. Geschwindigkeit* - Velocità max*		m/s	0,75*	
Max. stroke length - Max. Hub - Corsa max		mm	1000	
Min. stroke length - Min. Hub - Corsa min		mm	100	100
Pitch - Spindelsteigung - Passo vite		mm	5	10
Screw diameter - Spindeldurchmesser - Diametro vite		mm	12	
Base weight - Gewicht bei 0mm Hub - Peso corsa 0 mm		Kg	1,8	
Add for 100 mm of stroke - Gewicht bei 100mm Hub - Peso corsa 100 mm		Kg	0,45	
Max. load** - Max. Belastung** - Carico max**	Fx	N	980	750
	Fy	N	1250	1250
	Fz	N	1250	1250
Moments* - Max. Belastungsmoment* - Momenti max*	Mx	Nm	20	20
	My	Nm	45	45
	Mz	Nm	45	45
Inertia moment profile - Flächenträgheitmoment - Momento d'inerzia profilo	Ix	cm <sup>4</sup>	15,1	
Inertia moment profile - Flächenträgheitmoment - Momento d'inerzia profilo	Iy	cm <sup>4</sup>	15,5	
Repeatability - Wiederholgenauigkeit - Ripetibilità		mm	± 0,02	
Screw class - Klasse Kugelgewinde - Classe vite			T7	
No load torque - Leerlaufmoment - Coppia resistente		Nm	0,2	0,15

\* It depends from stroke and the spindle lead

\* In Abhängigkeit von Hub und Spindelsteigung

\* Valore indicativo, dipende dalla corsa e dal passo vite

\*\* Max values for dynamic conditions. Please refer to the following formula when combined loads are applied.

\*\* Für die Ermittlung der maximalen dynamischen Tragzahlen bei kombinierten Kraftangriffspunkten, nutzen Sie bitte die nebenstehende Berechnungsformel.

\*\* Valori massimi in condizioni dinamiche. In presenza di carichi combinati riferirsi alla formula per la verifica dei carichi massimi da applicare.

$$\frac{F_{yA}}{F_y} + \frac{F_{zA}}{F_z} + \frac{M_{xA}}{M_x} + \frac{M_{yA}}{M_y} + \frac{M_{zA}}{M_z} \leq 1$$

The A letters show the calculated value.  
Der A Parameter entspricht dem errechneten Wert.  
La lettera A indica i valori complessivi calcolati

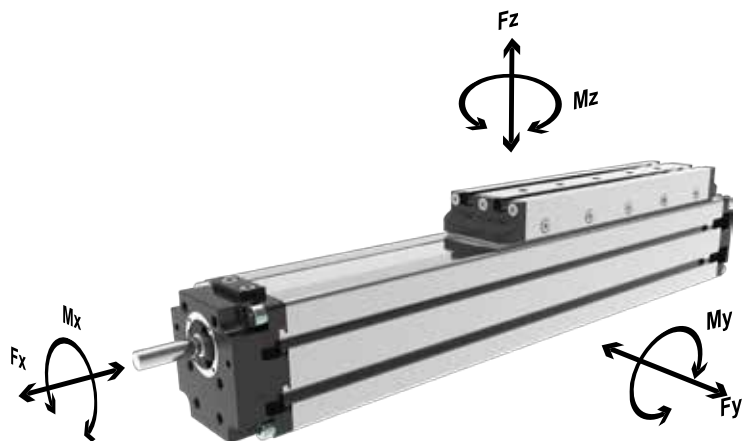

# 18TV42 Series Baureihe 18TV42 | Serie 18TV42

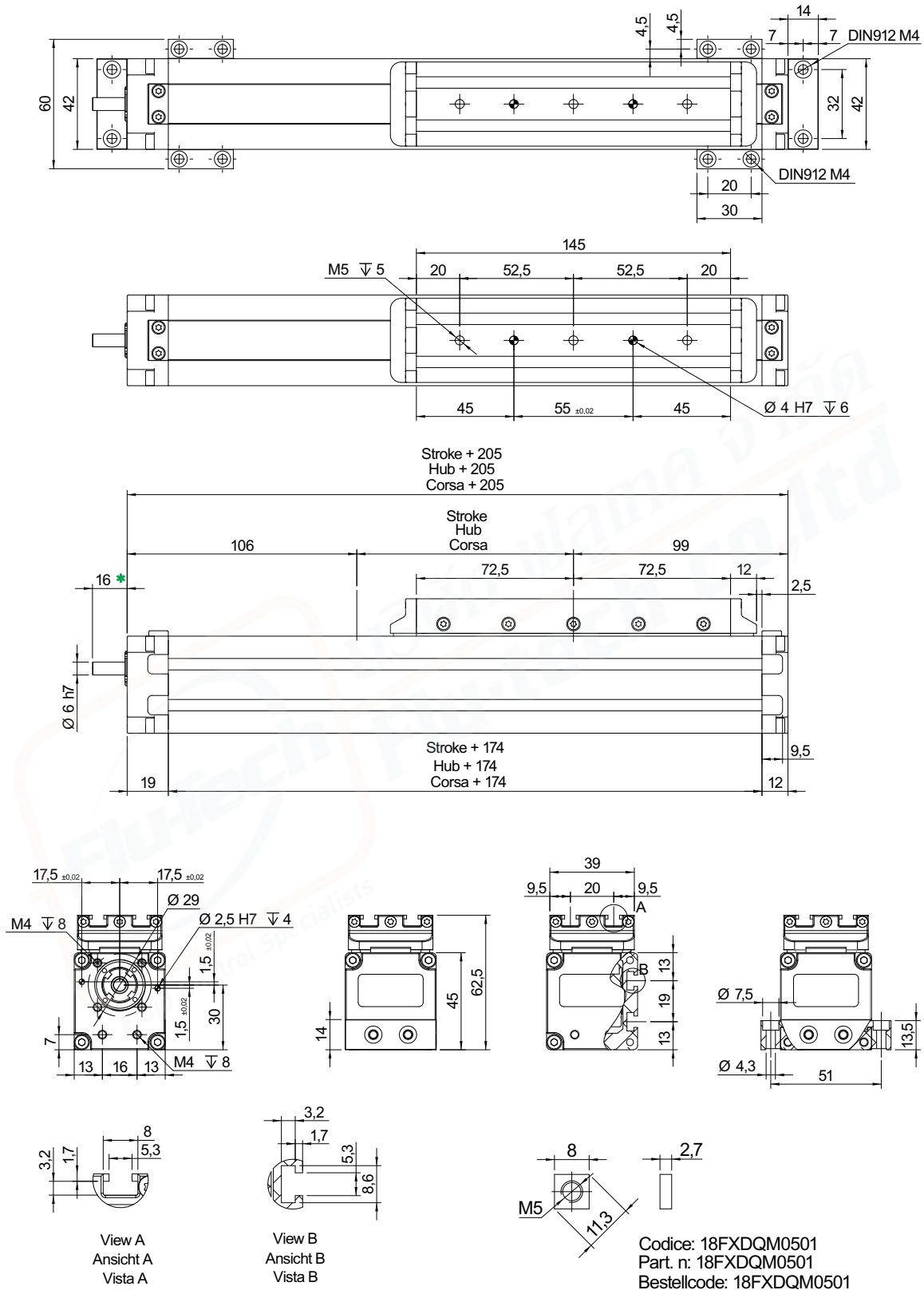



## 18TV42 Series Baureihe 18TV42 | Serie 18TV42

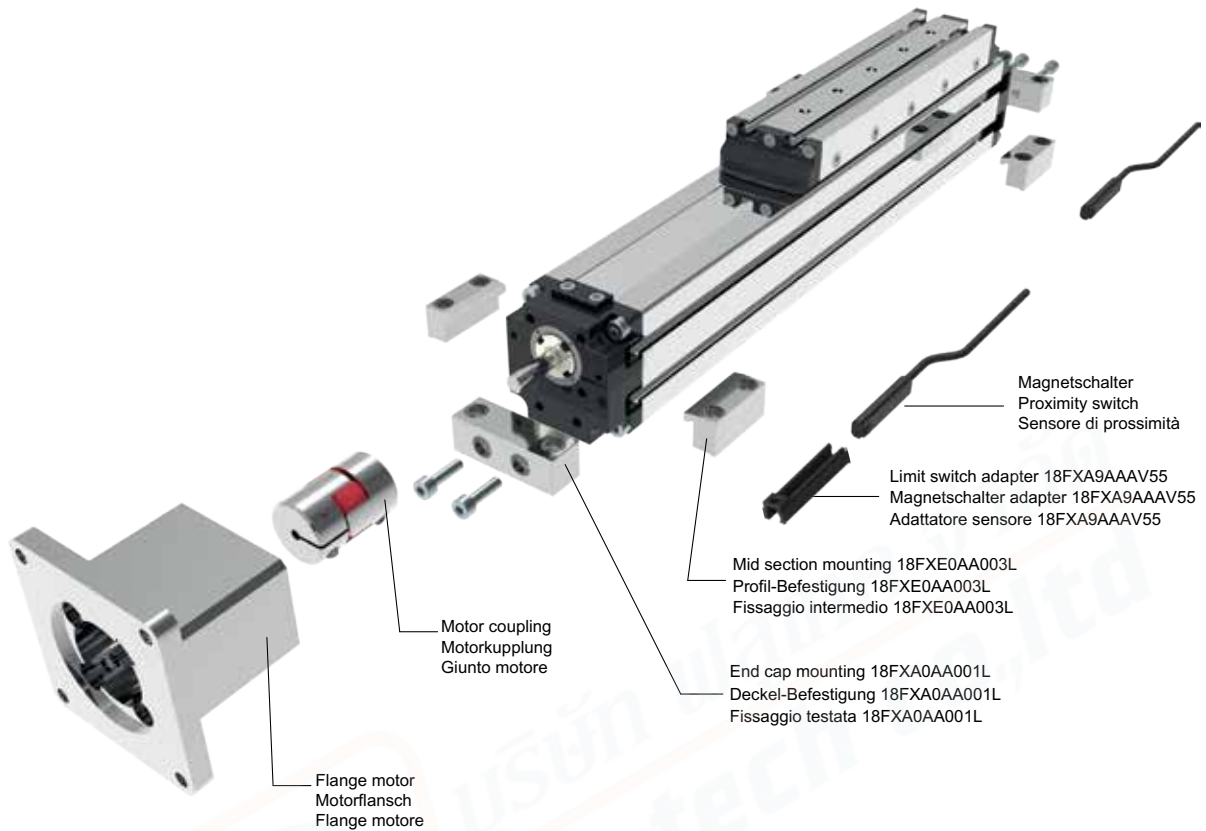

### ORDERING INFORMATION | Bestallangaben Baureihe | Codici per l'ordinazione

Proximity switch		Magnetschalter	Sensore di prossimità
Part nr.   Ident nr.   Cod.	Cable   Kabel   Cavo	Output   Ausgangsfunktion   Uscita	
1581.HAP	with 2,5 mt cable - NO   mit 2,5 mt Kabel - NO   con cavo 2,5 mt - NA	PNP, Hall	
THS.P	100 mm with M8 plug in   mit 100 mm Kabel und M8 Stecker   100 mm conn. M8	PNP, Hall	

For the technical characteristics, see the General Catalogue, Section 6 "Magnetic sensors" | Die Eigenschaften von Sensoren sind im allgemeinen Katalog, Abschnitt 6 "magnetische Sensoren dargestellt" | Per le caratteristiche dei sensori, vedi il Catalogo Generale, Sezione 6 "Sensori magnetici"

## 18TV42.0500.A.R.A

**Stroke mm**  
Hub mm  
Corsa mm

**Screw pitch**  
Spindelsteigung  
Passo vite  
A = 5 mm  
B = 10 mm

**Shaft** | Versionen Antriebeswelle | Versione Albero

A: Without key shaft | Ohne Passfeder | Senza chiavetta  
B: With key shaft | Mit Passfeder | Con sede chiavetta

## 18TV55 Series Baureihe 18TV55 | Serie 18TV55

### Screw driven guided linear unit

Linearantrieb mit Rundspindel und integrierter Kugelumlauführung  
Attuatori lineari a vite e guida a ricircolo di sfere

#### TECHNICAL DATA | TECHNISCHE DATEN | DATI TECNICI

Size - Baugröße - Taglia		55x60			
Max. speed* - Max. Geschwindigkeit* - Velocità max*	m/s	1			
Max. stroke length - Max. Hub - Corsa max	mm	1000	1250	1500	
Min. stroke length - Min. Hub - Corsa min	mm	100	100	100	
Pitch - Spindelsteigung - Passo vite	mm	5	10	16	
Screw diameter - Spindeldurchmesser - Diametro vite	mm	16			
Base weight - Gewicht bei 0mm Hub - Peso corsa 0 mm	Kg	3,2			
Add for 100 mm of stroke - Gewicht bei 100mm Hub - Peso corsa 100 mm	Kg	0,6			
Max. load** - Max. Belastung ** - Carico max**	Fx	N	1850	1420	1025
	Fy	N	4500	4500	4500
	Fz	N	4500	4500	4500
Moments* - Max. Belastungsmoment* - Momenti max*	Mx	Nm	30		
	My	Nm	155		
	Mz	Nm	155		
Inertia moment Aluminum profile - Flächenträgheitsmoment - Momento d'inerzia profilo	Ix	cm <sup>4</sup>	47,3		
Inertia moment Aluminum profile - Flächenträgheitsmoment - Momento d'inerzia profilo	Iy	cm <sup>4</sup>	49,5		
Repeatability - Wiederholgenauigkeit - Ripetibilità	mm	± 0,02			
Screw class - klasse Kugelgewinde - Classe vite		T7			
No load torque - Leerlaufmoment - Coppia resistente	Nm	0,2	0,15	0,1	

\* It depends from stroke and the spindle pitch

\* In Abhängigkeit von Hub und Spindelsteigung

\* Valore indicativo, dipende dalla corsa e dal passo vite

\*\* Max values for dynamic conditions. Please refer to the following formula when combined loads are applied.

\*\* Für die Ermittlung der maximalen dynamischen Tragzahlen bei kombinierten Kraftangriffspunkten, nutzen Sie bitte die nebenstehende Berechnungsformel.

\*\* Valori massimi in condizioni dinamiche. In presenza di carichi combinati riferirsi alla formula per la verifica dei carichi massimi da applicare.

$$\frac{F_{yA}}{F_y} + \frac{F_{zA}}{F_z} + \frac{M_{xA}}{M_x} + \frac{M_{yA}}{M_y} + \frac{M_{zA}}{M_z} \leq 1$$

The A letters show the calculated value.

Der A Parameter entspricht dem errechneten Wert.

La lettera A indica i valori complessivi calcolati

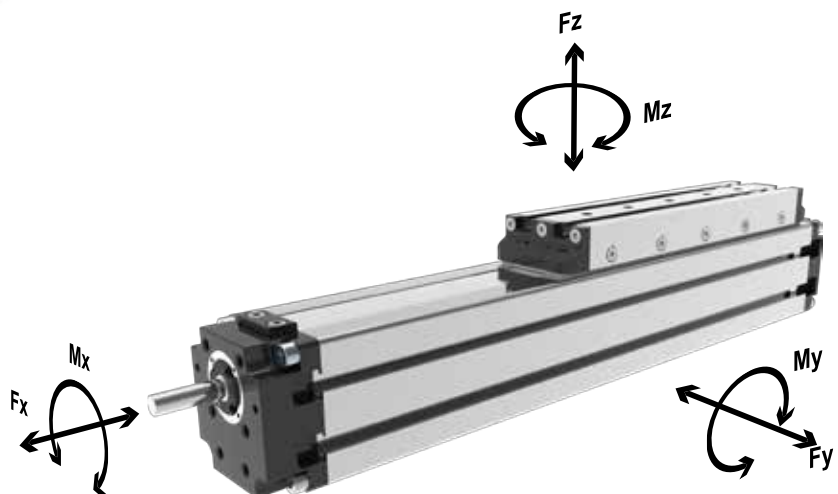



# 18TV55 Series Baureihe 18TV55 | Serie 18TV55

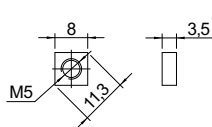
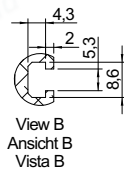
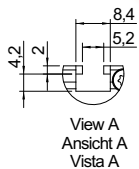
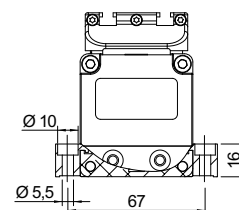
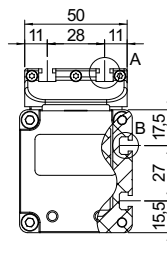
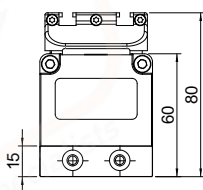
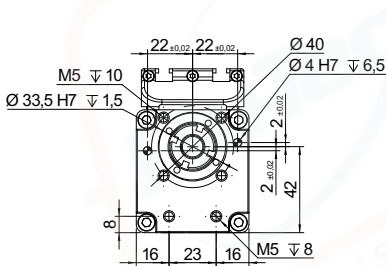
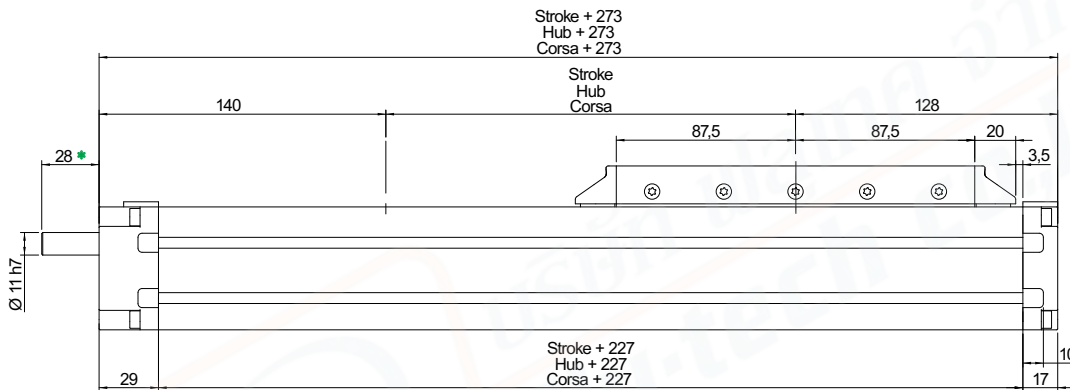
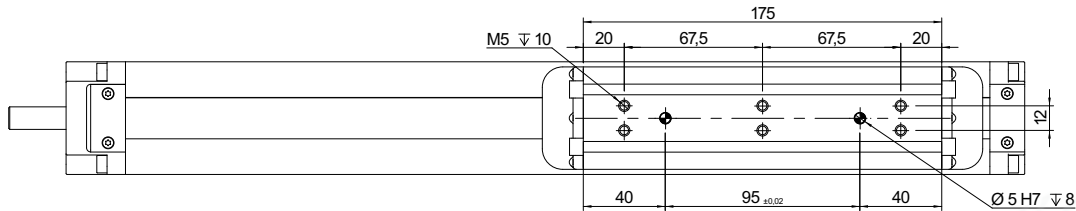
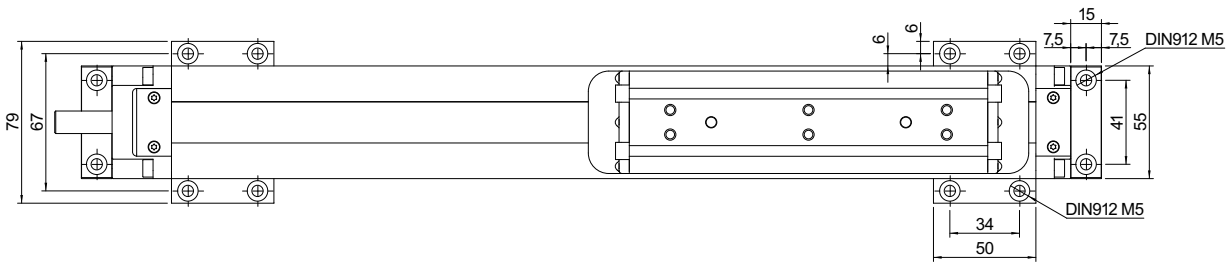

Codice: 18FXDQM05  
Part n: 18FXDQM05  
Bestellcode: 18FXDQM05

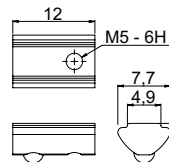

Codice: 18FXDTM05M5  
Part.n: 18FXDTM05M5  
Bestellcode: 18FXDTM05M5

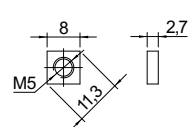

Codice: 18FXDQM0501  
Part. n: 18FXDQM0501  
Bestellcode: 18FXDQM0501

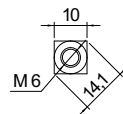

Part.n: 18FXDQM06  
Bestellcode: 18FXDQM06  
Codice: 18FXDQM06

Measure likely to change according to customer request  
Messen sich wahrscheinlich ändern nach Kundenwunsch  
Misura suscettibile di modifica su richiesta del cliente

ELECTRIC ACTUATION - ELEKTRISCHE ANTRIEBE - ATTUAZIONE ELETTRICA

# 18TV55 Series Baureihe 18TV55 | Serie 18TV55

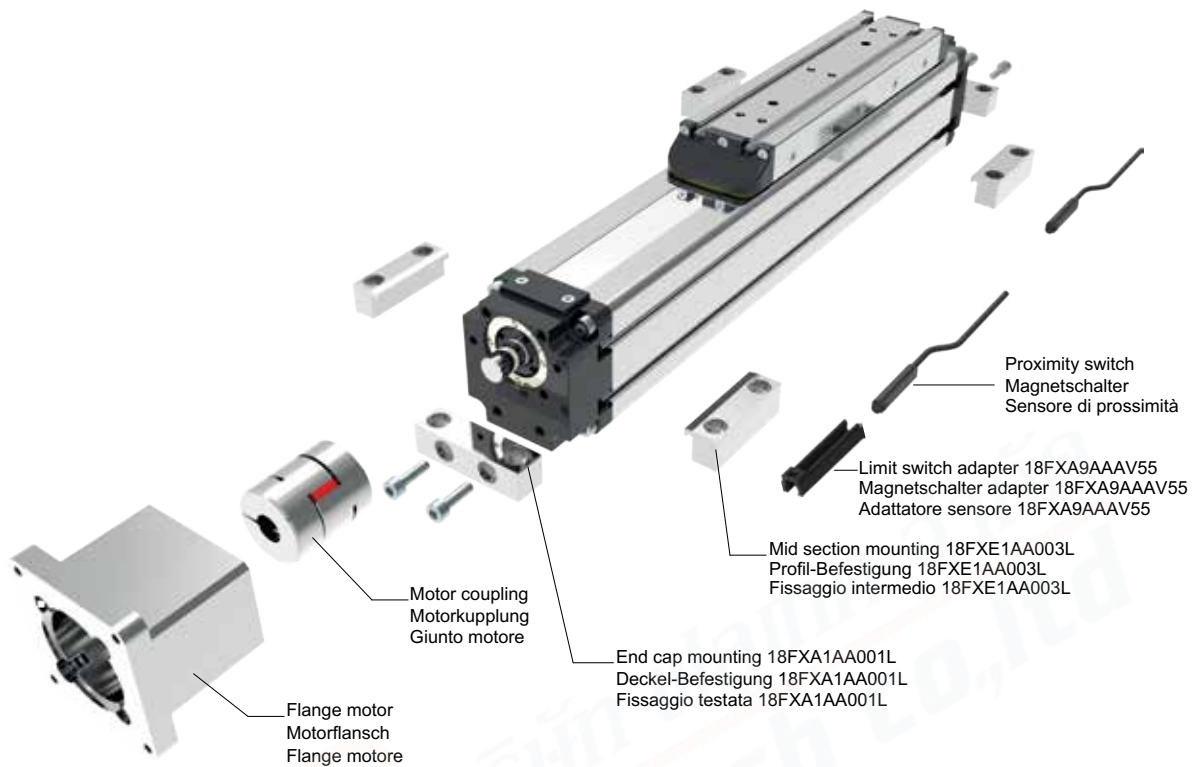

## ORDERING INFORMATION | Bestallangaben Baureihe | Codici per l'ordinazione

Proximity switch		Magnetschalter	Sensore di prossimità
Part nr.   Ident nr.   Cod.	Cable   Kabel   Cavo	Output   Ausgangsfunktion   Uscita	
1581.HAP	with 2,5 mt cable - NO   mit 2,5 mt Kabel - NO   con cavo 2,5 mt - NA	PNP, Hall	
THS.P	100 mm with M8 plug in   mit 100 mm Kabel und M8 Stecker   100 mm conn. M8	PNP, Hall	

For the technical characteristics, see the General Catalogue, Section 6 "Magnetic sensors" | Die Eigenschaften von Sensoren sind im allgemeinen Katalog, Abschnitt 6 "magnetische Sensoren dargestellt" | Per le caratteristiche dei sensori, vedi il Catalogo Generale, Sezione 6 "Sensori magnetici"

## 18TV55.0500.A.R.A

**Stroke mm**  
Hub mm  
Corsa mm

**Screw pitch**  
Spindelsteigung  
Passo vite  
A = 5 mm  
B = 10 mm  
C = 16 mm

**Shaft** | Versionen Antriebeswelle | Versione Albero

A: Without key shaft | Ohne Passfeder | Senza chiavetta  
B: With key shaft | Mit Passfeder | Con sede chiavetta



## 18TV80 Series Baureihe 18TV80 | Serie 18TV80

### Screw driven guided linear unit

Linearantrieb mit Rundspindel und integrierter Kugelumlauführung  
Attuatori lineari a vite e guida a ricircolo di sfere

#### TECHNICAL DATA | TECHNISCHE DATEN | DATI TECNICI

Size - Baugröße - Taglia	80x85				
Max. stroke length - Max. Hub - Corsa max	mm	1000	1250	1500	
Min. stroke length - Min. Hub - Corsa min	mm	100	100	100	
Pitch - Spindelsteigung - Passo vite	mm	5	10	20	
Screw diameter - Spindeldurchmesser - Diametro vite	mm	20			
Base weight - Gewicht bei 0mm Hub - Peso corsa 0 mm	Kg	7,5			
Add for 100 mm of stroke - Gewicht bei 100mm Hub - Peso corsa 100 mm	Kg	1,2			
Max. load** - Max. Belastung ** - Carico max**	Fx	N	3597	2996	1798
	Fy	N	8500		
	Fz	N	8500		
Moments* - Max. Belastungsmoment* - Momenti max*	Mx	Nm	90		
	My	Nm	500		
	Mz	Nm	500		
Inertia moment Aluminum profile - Flächenträgheitsmoment - Momento d'inerzia profilo	Ix	cm <sup>4</sup>	190		
Inertia moment Aluminum profile - Flächenträgheitsmoment - Momento d'inerzia profilo	Iy	cm <sup>4</sup>	190,2		
Repeatability - Wiederholgenauigkeit - Ripetibilità	mm	± 0,02			
Screw class - klasse Kugelgewinde - Classe vite	T7				
No load torque - Leerlaufmoment - Coppia resistente	Nm	0,3	0,2	0,15	

\* It depends from stroke and the spindle pitch

\* In Abhängigkeit von Hub und Spindelsteigung

\* Valore indicativo, dipende dalla corsa e dal passo vite

\*\* Max values for dynamic conditions. Please refer to the following formula when combined loads are applied.

\*\* Für die Ermittlung der maximalen dynamischen Tragzahlen bei kombinierten Kraftangriffspunkten, nutzen Sie bitte die nebenstehende Berechnungsformel.

\*\* Valori massimi in condizioni dinamiche. In presenza di carichi combinati riferirsi alla formula per la verifica dei carichi massimi da applicare.

$$\frac{F_{yA}}{F_y} + \frac{F_{zA}}{F_z} + \frac{M_{xA}}{M_x} + \frac{M_{yA}}{M_y} + \frac{M_{zA}}{M_z} \leq 1$$

The A letters show the calculated value.  
Der A Parameter entspricht dem errechneten Wert.  
La lettera A indica i valori complessivi calcolati

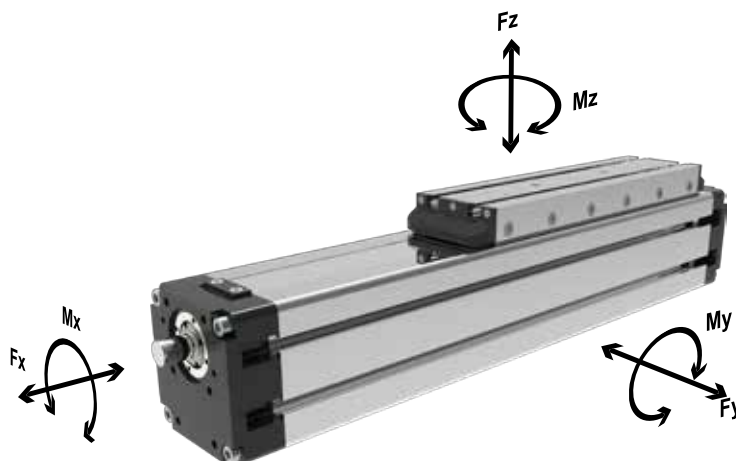

# 18TV80 Series Baureihe 18TV80 | Serie 18TV80

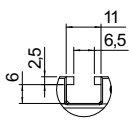
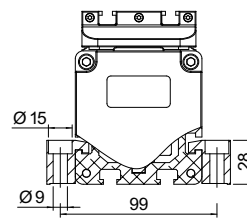
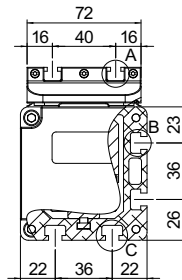
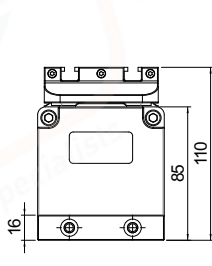
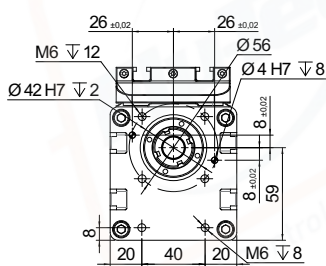
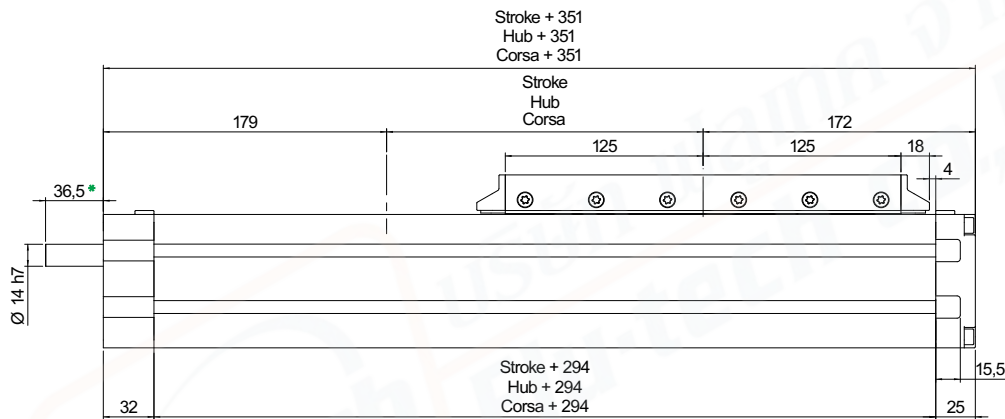
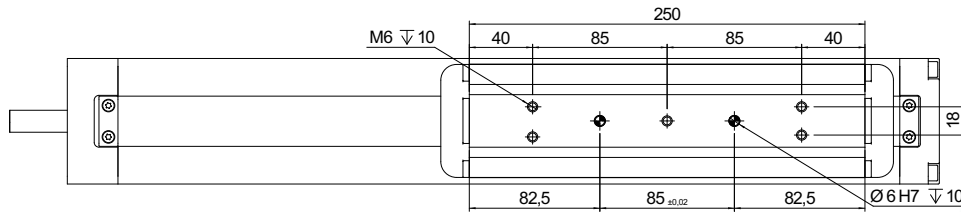
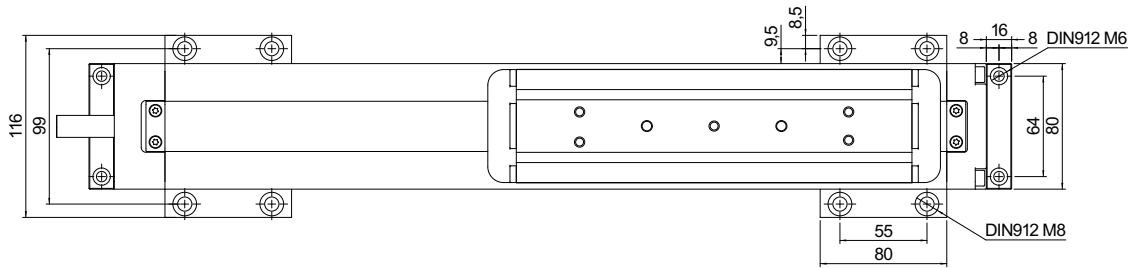

View A  
Ansicht A  
Vista A

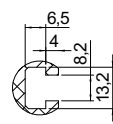

View B  
Ansicht B  
Vista B

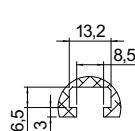

View C  
Ansicht C  
Vista C

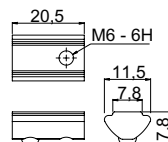

Part.n: 18FXDTM08M6  
Bestellcode: 18FXDTM08M6  
Codice: 18FXDTM08M6

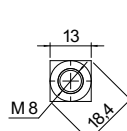

Part.n: 18FXDQM08  
Bestellcode: 18FXDQM08  
Codice: 18FXDQM08

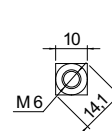

Part.n: 18FXDQM06  
Bestellcode: 18FXDQM06  
Codice: 18FXDQM06

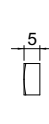

Measure likely to change according to customer request  
Messen sich wahrscheinlich ändern nach Kundenwunsch  
Misura suscettibile di modifica su richiesta del cliente

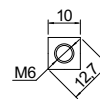

Codice: 18FXDQM0601  
Part.n.: 18FXDQM0601  
Bestellcode: 18FXDQM0601



# 18TV80 Series Baureihe 18TV80 | Serie 18TV80

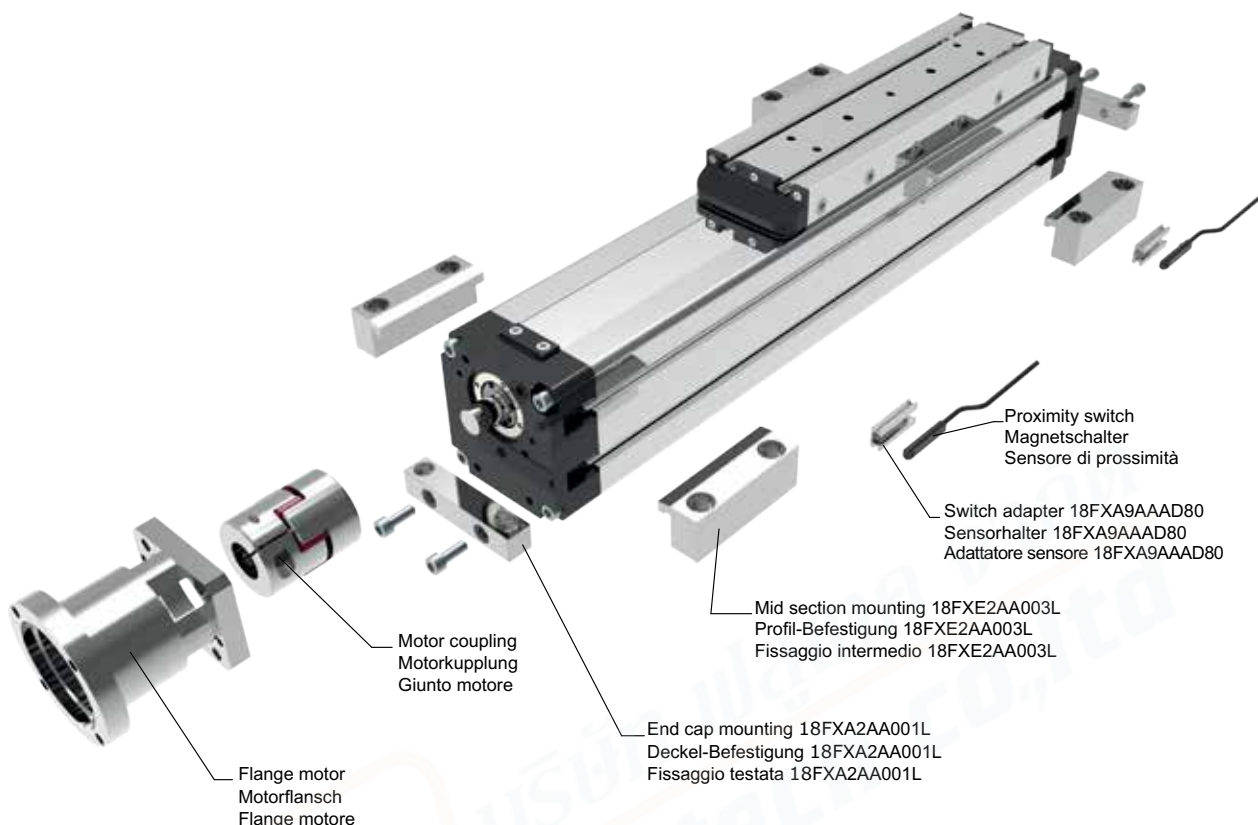

## ORDERING INFORMATION | Bestallangaben Baureihe | Codici per l'ordinazione

Proximity switch		Magnetschalter	Sensore di prossimità
Part nr.   Ident nr.   Cod.	Cable   Kabel   Cavo	Output   Ausgangfunktion   Uscita	
1580.HAP	with 2,5 mt cable - NO   mit 2,5 mt Kabel - NO   con cavo 2,5 mt - NA	PNP, Hall	
1580.HAN	with 2,5 mt cable - NO   mit 2,5 mt Kabel - NO   con cavo 2,5 mt - NA	NPN, Hall	
MHS.P	300 mm with M8 plug in   mit 300 mm Kabel und M8 Stecker   300 mm conn. M8	PNP, Hall	

For the technical characteristics, see the General Catalogue, Section 6 "Magnetic sensors" | Die Eigenschaften von Sensoren sind im allgemeinen Katalog, Abschnitt 6 "magnetische Sensoren dargestellt" | Per le caratteristiche dei sensori, vedi il Catalogo Generale, Sezione 6 "Sensori magnetici"

## 18TV80.0500.A.R.A

**Stroke mm**  
Hub mm  
Corsa mm

**Screw pitch**  
Spindelsteigung  
Passo vite  
A = 5 mm  
B = 10 mm  
C = 20 mm

**Shaft** | Versionen Antriebeswelle | Versione Albero

A: Without key shaft | Ohne Passfeder | Senza chiavetta  
B: With key shaft | Mit Passfeder | Con sede chiavetta

# 18TVS55 Series Baureihe 18TVS55 | Serie 18TVS55

## Screw driven guided linear unit

Linearantrieb mit Rundspindel und integrierter Kugelumlaufführung  
Attuatori lineari a vite e guida a ricircolo di sfere

### TECHNICAL DATA | TECHNISCHE DATEN | DATI TECNICI

Size - Baugröße - Taglia			55x60		
Max. speed* - Max. Geschwindigkeit* - Velocità max*	m/s		1		
Max. stroke length - Max. Hub - Corsa max	mm	1000	1250	1500	
Min. stroke length - Min. Hub - Corsa min	mm	100	100	100	
Pitch - Spindelsteigung - Passo vite	mm	5	10	16	
Screw diameter - Spindeldurchmesser - Diametro vite	mm	16			
Base weight - Gewicht bei 0mm Hub - Peso corsa 0 mm	Kg	3,2			
Add for 100 mm of stroke - Gewicht bei 100mm Hub - Peso corsa 100 mm	Kg	0,6			
Max. load** - Max. Belastung ** - Carico max**	Fx	N	1850	1420	1025
	Fy	N	4500	4500	4500
	Fz	N	4500	4500	4500
Moments* - Max. Belastungsmoment* - Momenti max*	Mx	Nm	395		
	My	Nm	480		
	Mz	Nm	480		
Inertia moment Aluminum profile - Flächenträgheitsmoment - Momento d'inerzia profilo	Ix	cm <sup>4</sup>	47,3		
Inertia moment Aluminum profile - Flächenträgheitsmoment - Momento d'inerzia profilo	Iy	cm <sup>4</sup>	49,5		
Repeatability - Wiederholgenauigkeit - Ripetibilità	mm	± 0,02			
Screw class - klasse Kugelgewinde - Classe vite		T7			
No load torque - Leerlaufmoment - Coppia resistente	Nm	0,2	0,15		

\* It depends from stroke and the spindle pitch

\* In Abhängigkeit von Hub und Spindelsteigung

\* Valore indicativo, dipende dalla corsa e dal passo vite

\*\* Max values for dynamic conditions. Please refer to the following formula when combined loads are applied.

\*\* Für die Ermittlung der maximalen dynamischen Tragzahlen bei kombinierten Kraftangriffspunkten, nutzen Sie bitte die nebenstehende Berechnungsformel.

\*\* Valori massimi in condizioni dinamiche. In presenza di carichi combinati riferirsi alla formula per la verifica dei carichi massimi da applicare.

$$\frac{F_{yA}}{F_y} + \frac{F_{zA}}{F_z} + \frac{M_{xA}}{M_x} + \frac{M_{yA}}{M_y} + \frac{M_{zA}}{M_z} \leq 1$$

The A letters show the calculated value.  
Der A Parameter entspricht dem errechneten Wert.  
La lettera A indica i valori complessivi calcolati

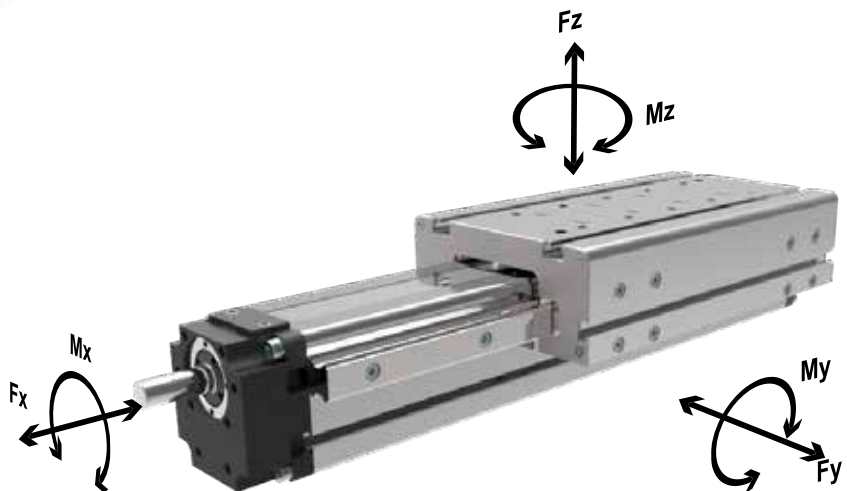



# 18TVS55 Series Baureihe 18TVS55 | Serie 18TVS55

ELECTRIC ACTUATION - ELEKTRISCHE ANTRIEBE - ATTUAZIONE ELETTRICA

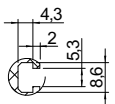
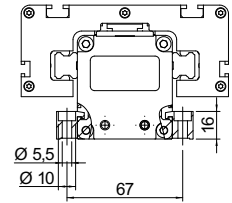
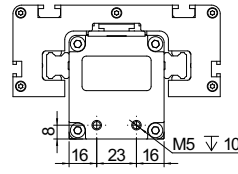
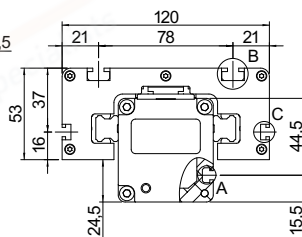
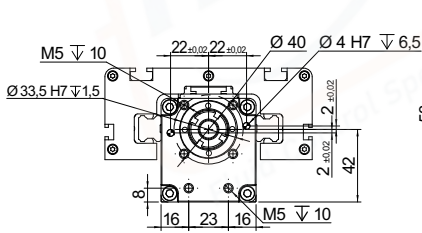
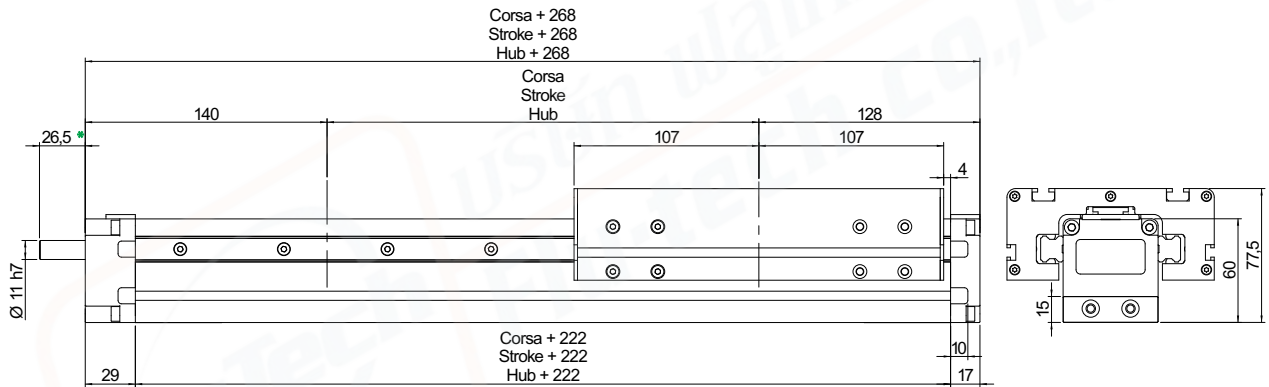
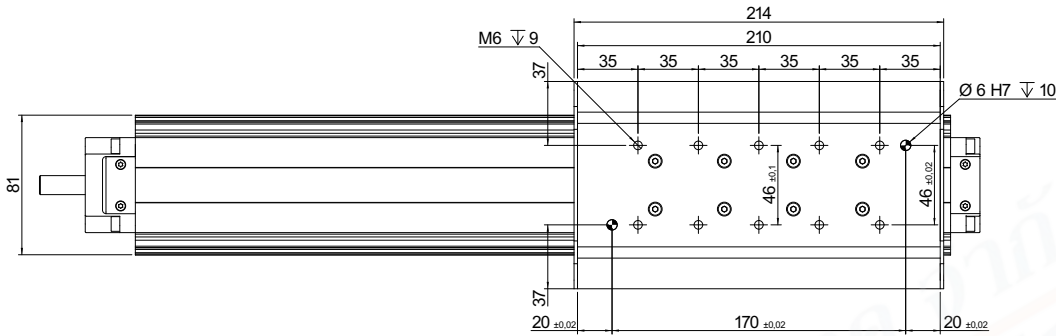
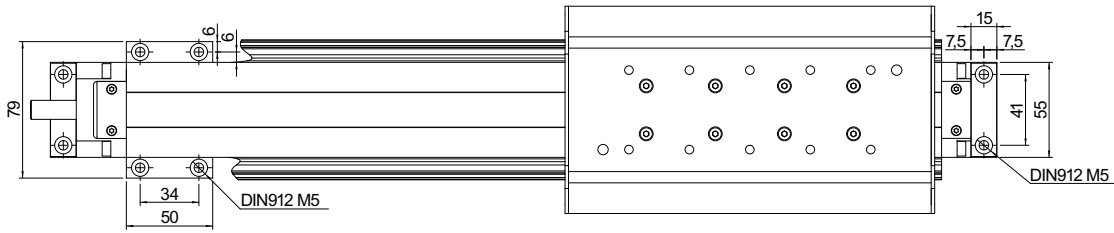

Vista A  
View A  
Ansicht A

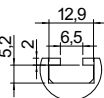

Vista B  
View B  
Ansicht B

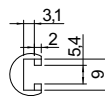

Vista C  
View C  
Ansicht C

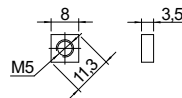

Codice: 18FXDQM05  
Part n: 18FXDQM05  
Bestellcode: 18FXDQM05

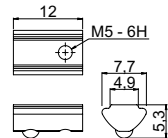

Codice: 18FXDTM05M5  
Part.n: 18FXDTM05M5  
Bestellcode: 18FXDTM05M5

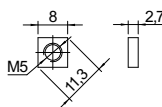

Codice: 18FXDQM0501  
Part. n: 18FXDQM0501  
Bestellcode: 18FXDQM0501

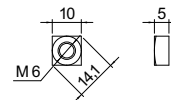

Part.n: 18FXDQM06  
Bestellcode: 18FXDQM06  
Codice: 18FXDQM06

• Misura suscettibile di modifica su richiesta del cliente  
Measure likely to change according to customer request  
Messen sich wahrscheinlich ändern nach Kundenwunsch

# 18TVS55 Series Baureihe 18TVS55 | Serie 18TVS55

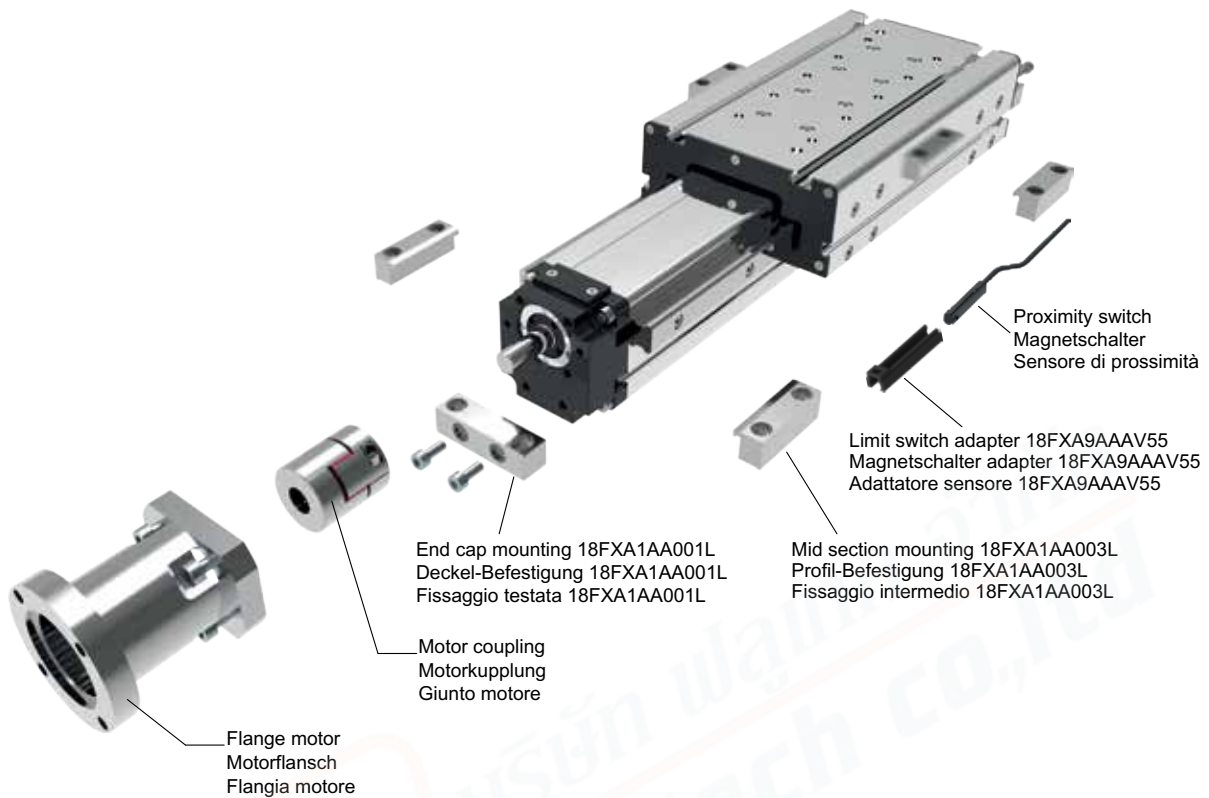

## ORDERING INFORMATION | Bestallangaben Baureihe | Codici per l'ordinazione

Proximity switch		Magnetschalter	Sensore di prossimità
Part nr.   Ident nr.   Cod.	Cable   Kabel   Cavo	Output   Ausgangfunktion   Uscita	
1581.HAP	with 2,5 mt cable - NO   mit 2,5 mt Kabel - NO   con cavo 2,5 mt - NA	PNP, Hall	
THS.P	100 mm with M8 plug in   mit 100 mm Kabel und M8 Stecker   100 mm conn. M8	PNP, Hall	

For the technical characteristics, see the General Catalogue, Section 6 "Magnetic sensors" | Die Eigenschaften von Sensoren sind im allgemeinen Katalog, Abschnitt 6 "magnetische Sensoren dargestellt" | Per le caratteristiche dei sensori, vedi il Catalogo Generale, Sezione 6 "Sensori magnetici"

## 18TVS55.0500.A.R.A

**Stroke mm**  
Hub mm  
Corsa mm

**Screw pitch**  
Spindelsteigung  
Passo vite  
A = 5 mm  
B = 10 mm  
C = 16 mm

**Shaft** | Versionen Antriebeswelle | Versione Albero

A: Without key shaft | Ohne Passfeder | Senza chiavetta  
B: With key shaft | Mit Passfeder | Con sede chiavetta



## 18TVS80 Series Baureihe 18TVS80 | Serie 18TVS80

### Screw driven guided linear unit

Linearantrieb mit Rundspindel und integrierter Kugelumlauführung  
Attuatori lineari a vite e guida a ricircolo di sfere

#### TECHNICAL DATA | TECHNISCHE DATEN | DATI TECNICI

Size - Baugröße - Taglia			80x85		
Max. speed* - Max. Geschwindigkeit* - Velocità max*	m/s		1,25		
Max. stroke length - Max. Hub - Corsa max	mm	1000	1250	1500	
Min. stroke length - Min. Hub - Corsa min	mm	100	100	100	
Pitch - Spindelsteigung - Passo vite	mm	5	10	20	
Screw diameter - Spindeldurchmesser - Diametro vite	mm	20			
Base weight - Gewicht bei 0mm Hub - Peso corsa 0 mm	Kg	7,5			
Add for 100 mm of stroke - Gewicht bei 100mm Hub - Peso corsa 100 mm	Kg	1,2			
Max. load** - Max. Belastung ** - Carico max**	Fx	N	3597	2996	1798
	Fy	N	8500		
	Fz	N	8500		
Moments* - Max. Belastungsmoment* - Momenti max*	Mx	Nm	620		
	My	Nm	730		
	Mz	Nm	730		
Inertia moment Aluminum profile - Flächenträgheitsmoment - Momento d'inerzia profilo	Ix	cm <sup>4</sup>	190		
Inertia moment Aluminum profile - Flächenträgheitsmoment - Momento d'inerzia profilo	Iy	cm <sup>4</sup>	190,2		
Repeatability - Wiederholgenauigkeit - Ripetibilità	mm	± 0,02			
Screw class - klasse Kugelgewinde - Classe vite	T7				
No load torque - Leerlaufmoment - Coppia resistente	Nm	0,4	0,3	0,2	

\* It depends from stroke and the spindle pitch

\* In Abhängigkeit von Hub und Spindelsteigung

\* Valore indicativo, dipende dalla corsa e dal passo vite

\*\* Max values for dynamic conditions. Please refer to the following formula when combined loads are applied.

\*\* Für die Ermittlung der maximalen dynamischen Tragzahlen bei kombinierten Kraftangriffspunkten, nutzen Sie bitte die nebenstehende Berechnungsformel.

\*\* Valori massimi in condizioni dinamiche. In presenza di carichi combinati riferirsi alla formula per la verifica dei carichi massimi da applicare.

$$\frac{F_{yA}}{F_y} + \frac{F_{zA}}{F_z} + \frac{M_{xA}}{M_x} + \frac{M_{yA}}{M_y} + \frac{M_{zA}}{M_z} \leq 1$$

The A letters show the calculated value.

Der A Parameter entspricht dem errechneten Wert.

La lettera A indica i valori complessivi calcolati

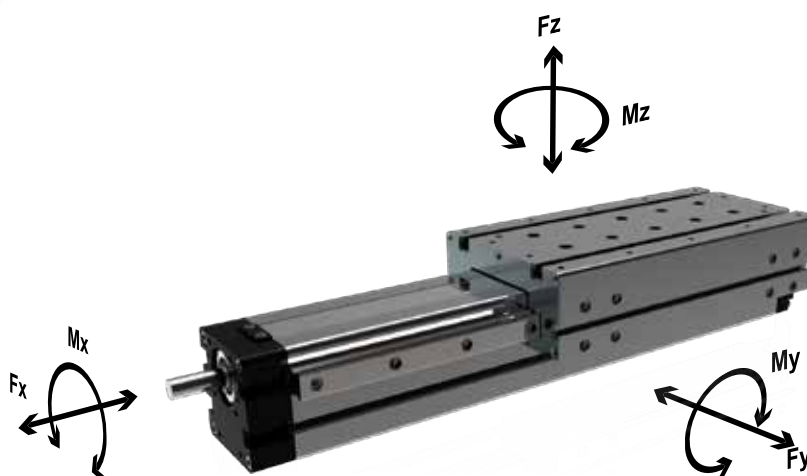

# 18TVS80 Series Baureihe 18TVS80 | Serie 18TVS80

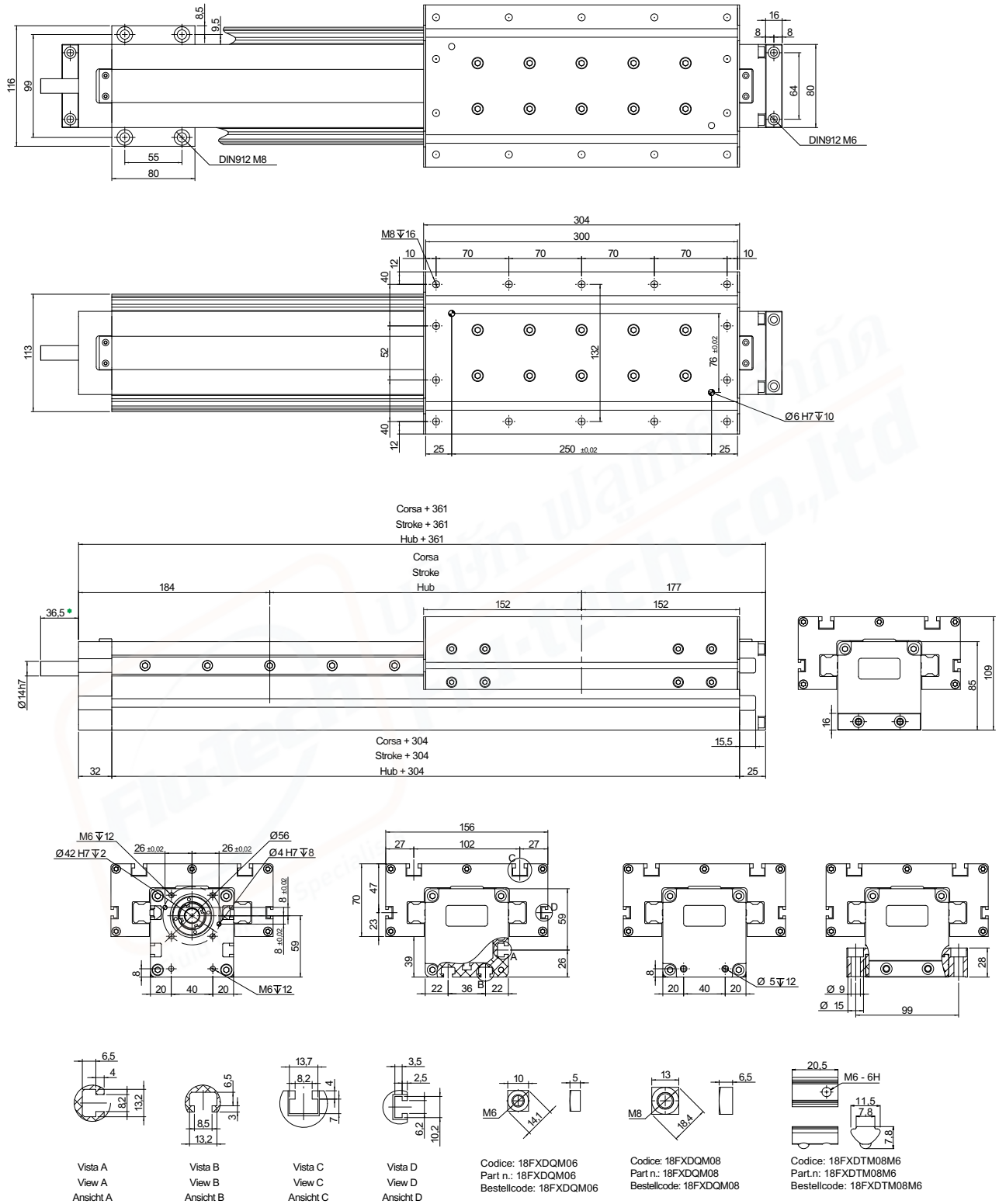

ELECTRIC ACTUATION - ELEKTRISCHE ANTRIEBE - ATTUAZIONE ELETTRICA

Misura suscettibile di modifica su richiesta del cliente  
Measure likely to change according to customer request  
Messen sich wahrscheinlich ändern nach Kundenwunsch



# 18TVS80 Series Baureihe 18TVS80 | Serie 18TVS80

ELECTRIC ACTUATION - ELEKTRISCHE ANTRIEBE - ATTUAZIONE ELETTRICA

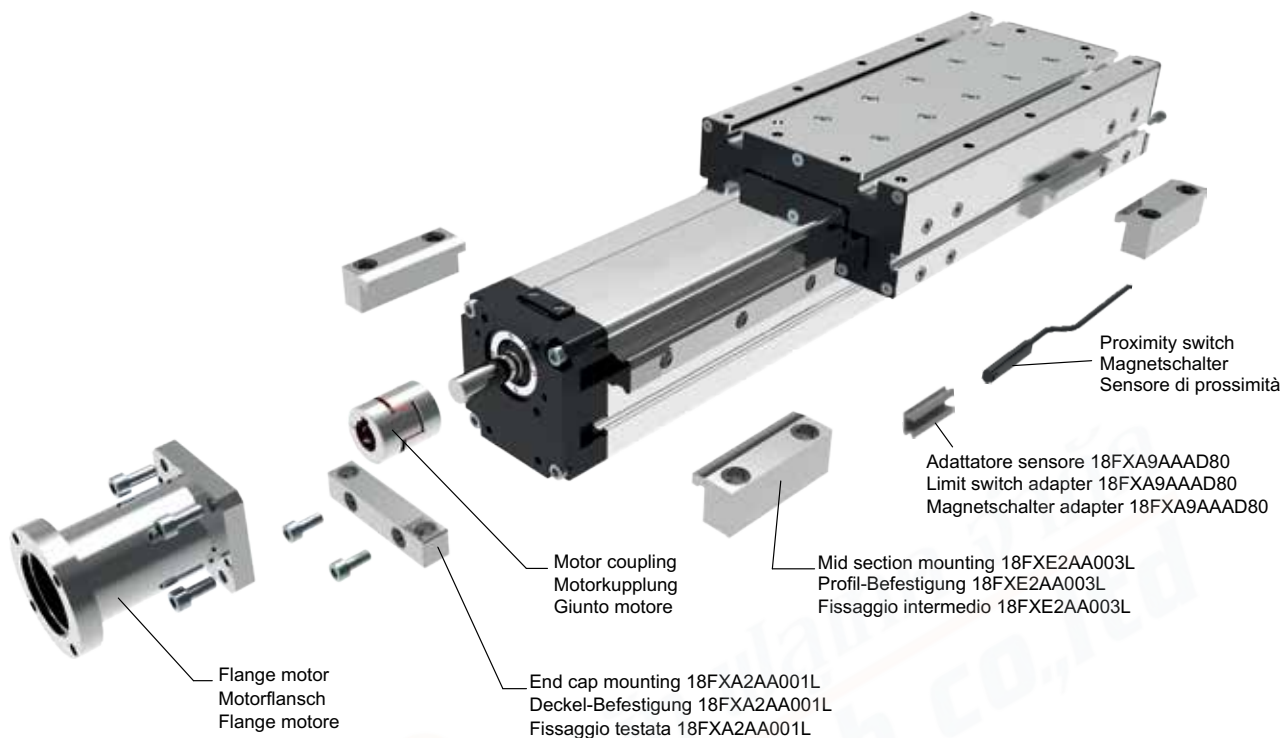

## ORDERING INFORMATION | Bestallangaben Baureihe | Codici per l'ordinazione

Proximity switch		Magnetschalter	Sensore di prossimità
Part nr.   Ident nr.   Cod.	Cable   Kabel   Cavo	Output   Ausgangfunktion   Uscita	
1580.HAP	with 2,5 mt cable - NO   mit 2,5 mt Kabel - NO   con cavo 2,5 mt - NA	PNP, Hall	
1580.HAN	with 2,5 mt cable - NO   mit 2,5 mt Kabel - NO   con cavo 2,5 mt - NA	NPN, Hall	
MHS.P	300 mm with M8 plug in   mit 300 mm Kabel und M8 Stecker   300 mm conn. M8	PNP, Hall	

For the technical characteristics, see the General Catalogue, Section 6 "Magnetic sensors" | Die Eigenschaften von Sensoren sind im allgemeinen Katalog, Abschnitt 6 "magnetische Sensoren dargestellt" | Per le caratteristiche dei sensori, vedi il Catalogo Generale, Sezione 6 "Sensori magnetici"

## 18TVS80.0500.A.R.A

**Stroke mm**  
Hub mm  
Corsa mm

**Screw pitch**  
Spindelsteigung  
Passo vite  
A = 5 mm  
B = 10 mm  
C = 20 mm

**Shaft** | Versionen Antriebeswelle | Versione Albero

A: Without key shaft | Ohne Passfeder | Senza chiavetta  
B: With key shaft | Mit Passfeder | Con sede chiavetta

# 18TUK40 Series Baureihe 18TUK40 | Serie 18TUK40

## Screw driven guided linear unit

Linearantrieb mit Rundspindel und integrierter Kugelumlaufführung  
Attuatori lineari a vite e guida a ricircolo di sfere

Carriages Laufwagen Carrelli	Max stroke Max Hub Corsa max	Min stroke Min Hub Corsa min	Pitch Steigung Passo vite	Ø screw Ø gewinde Ø vite	Base weight Grundmasse Peso base	Add for 100 mm Masse pro 100 mm Hub Peso ogni 100 mm	Inertia moment Ix Flächenträgheitsmoment Momento d'inerzia Ix	Inertia moment Iy Flächenträgheitsmoment Momento d'inerzia Iy
	mm	mm	mm	mm	kg	kg	cm <sup>4</sup>	cm <sup>4</sup>
1	1200	--	5	12	1,2	0,45	13	107
			10					
2	1200	--	5	12	2,1	0,45	13	107
			10					

Carriages Laufwagen Carrelli	Pitch Steigung Passo vite	Max Fx*	Max Fy*	Max Fz*	Max Mx*	Max My*	Max Mz*
		N	N	N	Nm	Nm	Nm
1	5	980	2750	2750	85	145	145
	10	750					
2	5	980	3500	3500	210	350	350
	10	750					

\* The moments and the loads above are max. values. For any further information, please contact our technical department.

\* Die angegebenen Momente und Belastungen sind max. Werte, die nicht überschritten werden sollen. Für weitere Informationen wenden Sie sich bitte an unser Konstruktionsbüro.

\* I carichi e i momenti indicati sono massimi consigliati, per ulteriori informazioni consultare il ns ufficio tecnico.

$$\frac{F_{yA}}{F_y} + \frac{F_{zA}}{F_z} + \frac{M_{xA}}{M_x} + \frac{M_{yA}}{M_y} + \frac{M_{zA}}{M_z} \leq 1$$

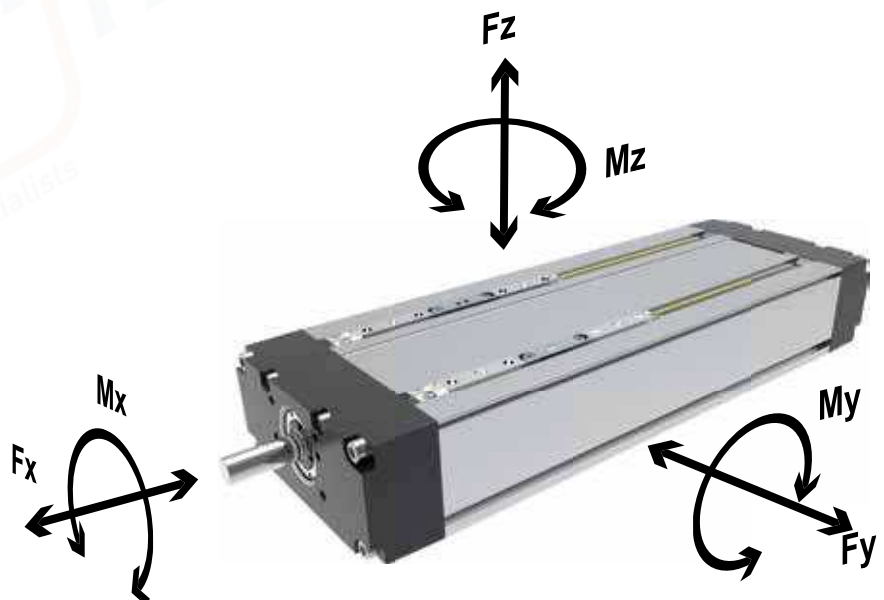



# 18TUK40 Series Baureihe 18TUK40 | Serie 18TUK40

ELECTRIC ACTUATION - ELEKTRISCHE ANTRIEBE - ATTUAZIONE ELETTRICA

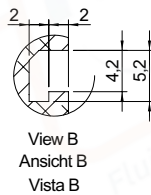
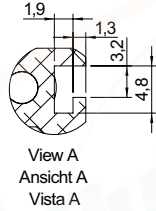
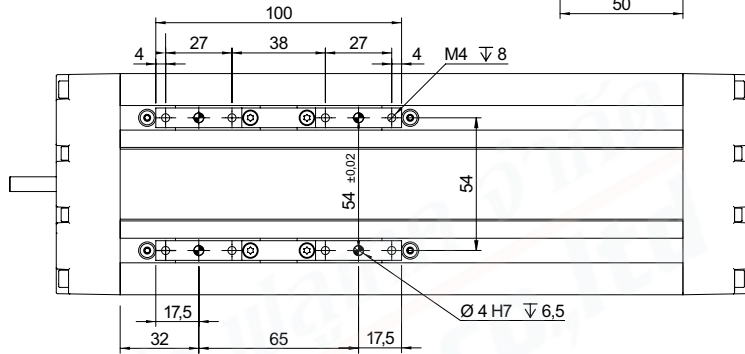
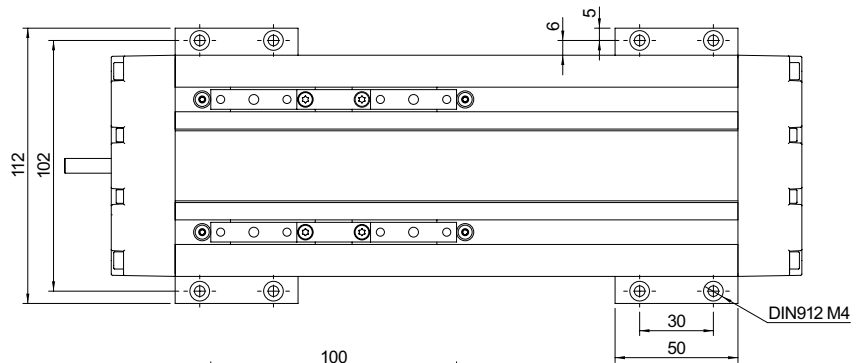
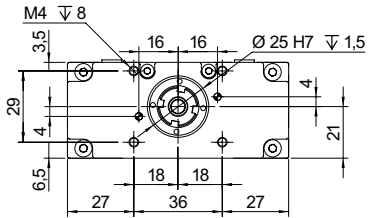
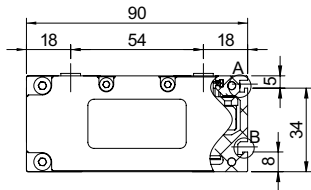
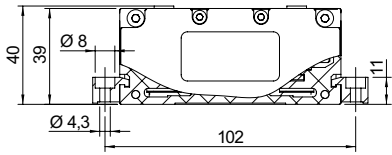

Double Carriage  
Tandem-Wagen  
Doppio Carrello

Stroke + 181  
Hub + 181  
Corsa + 181

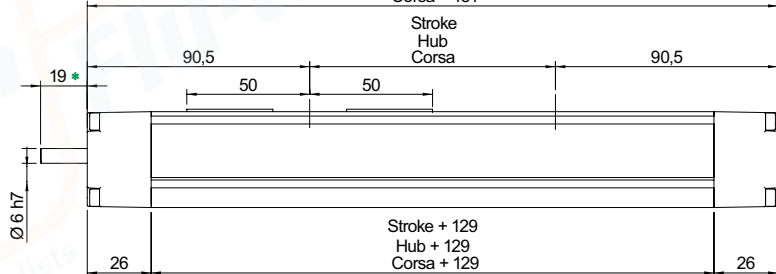

Single Carriage  
Uno-Wagen  
Carrello Singolo

Stroke + 116  
Hub + 116  
Corsa + 116

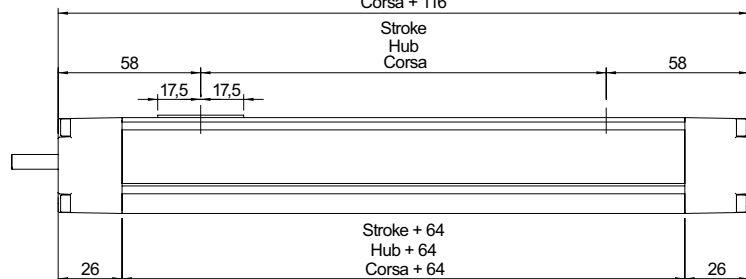

\* Measure likely to change according to customer request  
Messen sich wahrscheinlich ändern nach Kundenwunsch  
Misura suscettibile di modifica su richiesta del cliente

# 18TUK40 Series Baureihe 18TUK40 | Serie 18TUK40

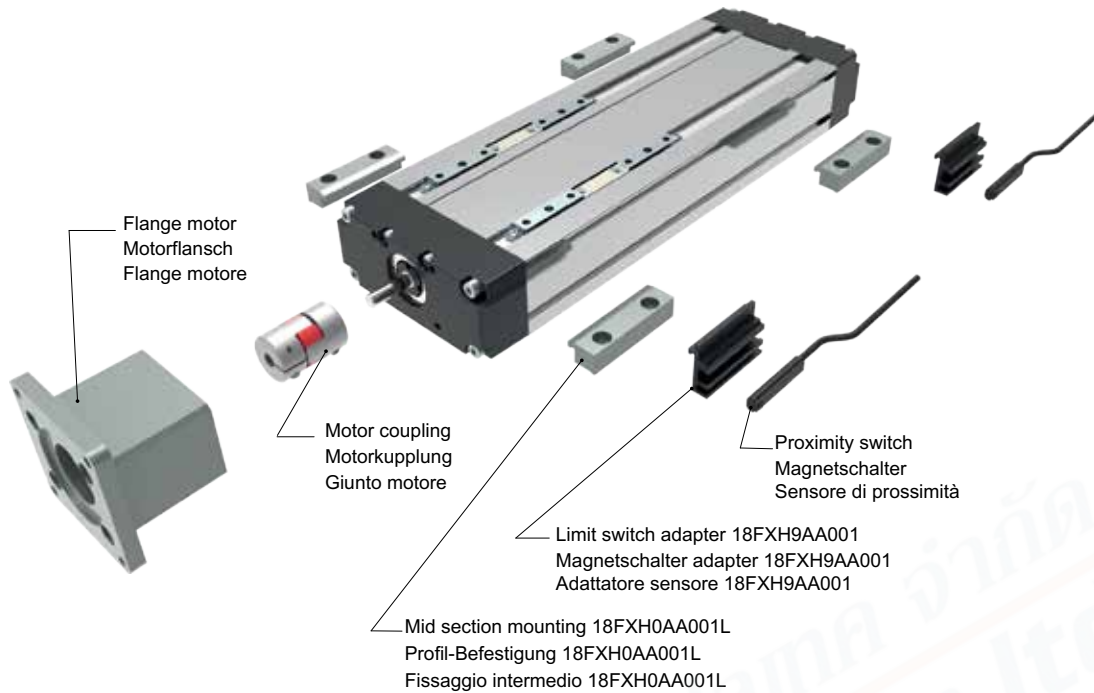

## ORDERING INFORMATION | Bestallangaben Baureihe | Codici per l'ordinazione

Proximity switch		Magnetschalter	Sensore di prossimità
Part nr.   Ident nr.   Cod.	Cable   Kabel   Cavo		Output   Ausgangfunktion   Uscita
1580.HAP	with 2,5 mt cable - NO   mit 2,5 mt Kabel - NO   con cavo 2,5 mt - NA		PNP, Hall
1580.HAN	with 2,5 mt cable - NO   mit 2,5 mt Kabel - NO   con cavo 2,5 mt - NA		NPN, Hall
MHS.P	300 mm with M8 plug in   mit 300 mm Kabel und M8 Stecker   300 mm conn. M8		PNP, Hall

For the technical characteristics, see the General Catalogue, Section 6 "Magnetic sensors" | Die Eigenschaften von Sensoren sind im allgemeinen Katalog, Abschnitt 6 "magnetische Sensoren dargestellt" | Per le caratteristiche dei sensori, vedi il Catalogo Generale, Sezione 6 "Sensori magnetici"

## 18TUK40.0500.A.R.A

**Stroke mm**  
Hub mm  
Corsa mm

**Shaft** | Versionen Antriebeswelle | Versione Albero

A: Without key shaft | Ohne Passfeder | Senza chiavetta  
B: With key shaft | Mit Passfeder | Con sede chiavetta

**Screw pitch / N. Carriages**

Spindelsteigung / Anzahl Wagen  
Passo vite / Numero carrelli  
A = 5 mm / n° 1  
B = 5 mm / n° 2  
C = 10 mm / n° 1  
D = 10 mm / n° 2





## 18TUK50 Series Baureihe 18TUK50 | Serie 18TUK50

### Screw driven guided linear unit

Linearantrieb mit Rundspindel und integrierter Kugelumlaufführung  
Attuatori lineari a vite e guida a ricircolo di sfere

Carriages Laufwagen Carrelli	Max stroke Max Hub Corsa max	Min stroke Min Hub Corsa min	Pitch Steigung Passo vite	Ø screw Ø gewinde Ø vite	Base weight Grundmasse Peso base	Add for 100 mm Masse pro 100 mm Hub Peso ogni 100 mm	Inertia moment Ix Flächenträgheitsmoment Momento d'inerzia Ix	Inertia moment Iy Flächenträgheitsmoment Momento d'inerzia Iy
	mm	mm	mm	mm	kg	kg	cm <sup>4</sup>	cm <sup>4</sup>
1	1500	--	5	16	1,6	0,55	30	209
			10					
			16					
2	1500	--	5	16	2,8	0,55	30	209
			10					
			16					

Carriages Laufwagen Carrelli	Pitch Steigung Passo vite	Max Fx*	Max Fy*	Max Fz*	Max Mx*	Max My*	Max Mz*
		N	N	N	Nm	Nm	Nm
1	5	1850	4500	4500	325	210	210
	10	1420					
	16	1025					
2	5	1850	9750	9750	600	800	800
	10	1420					
	16	1025					

\* The moments and the loads above are max. values. For any further information, please contact our technical department.

\* Die angegebenen Momente und Belastungen sind max. Werte, die nicht überschritten werden sollen. Für weitere Informationen wenden Sie sich bitte an unser Konstruktionsbüro.

\* I carichi e i momenti indicati sono massimi consigliati, per ulteriori informazioni consultare il ns ufficio tecnico.

$$\frac{F_{yA}}{F_y} + \frac{F_{zA}}{F_z} + \frac{M_{xA}}{M_x} + \frac{M_{yA}}{M_y} + \frac{M_{zA}}{M_z} \leq 1$$

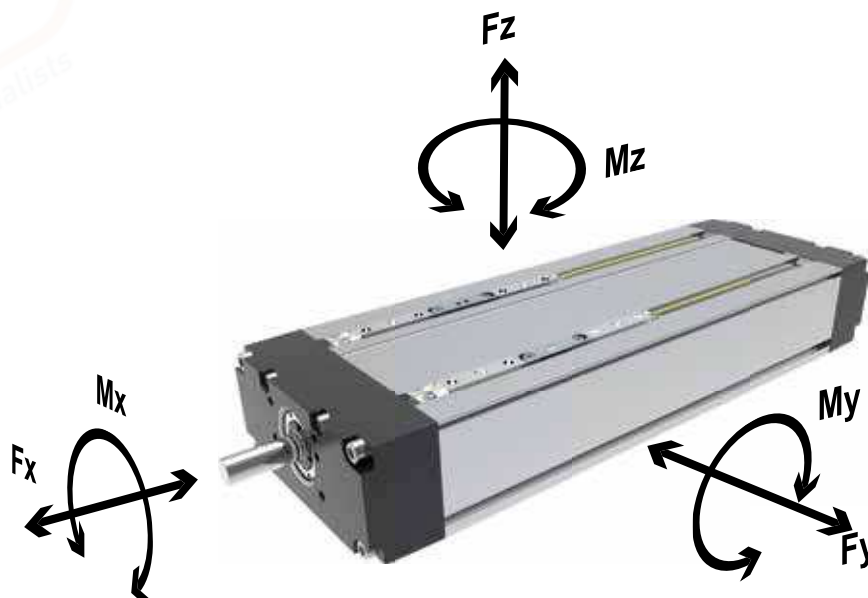

# 18TUK50 Series Baureihe 18TUK50 | Serie 18TUK50

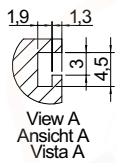
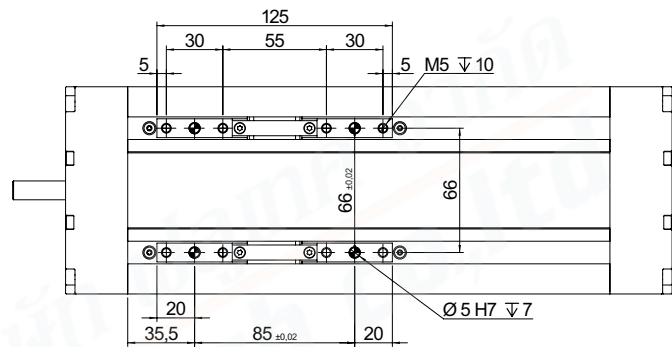
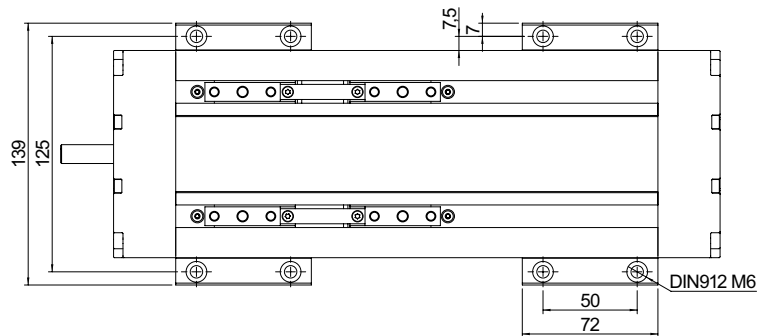
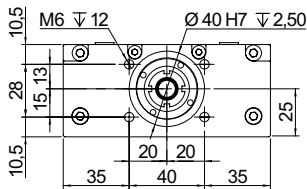
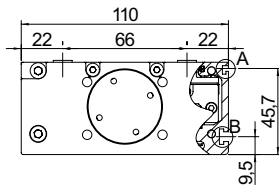
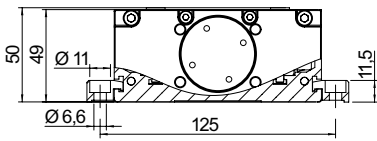

View A  
Ansicht A  
Vista A

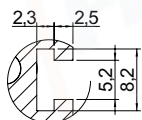

View B  
Ansicht B  
Vista B

Double Carriage  
Tandem-Wagen  
Doppio Carrello

Stroke + 222  
Hub + 222  
Corsa + 222

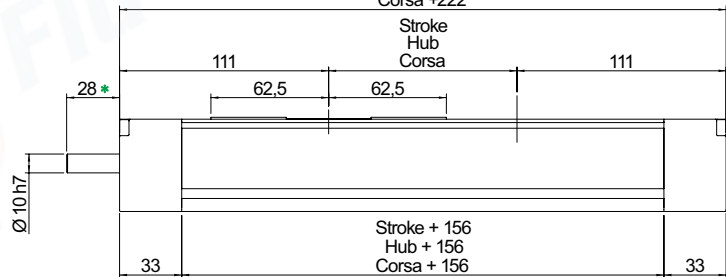

Single Carriage  
Uno-Wagen  
Carrello Singolo

Stroke + 137  
Hub + 137  
Corsa + 137

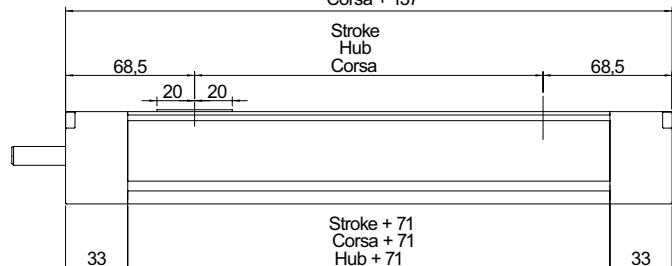

Stroke + 71  
Corsa + 71  
Hub + 71

Measure likely to change according to customer request  
Messen sich wahrscheinlich ändern nach Kundenwunsch  
Misura suscettibile di modifica su richiesta del cliente



# 18TUK50 Series Baureihe 18TUK50 | Serie 18TUK50

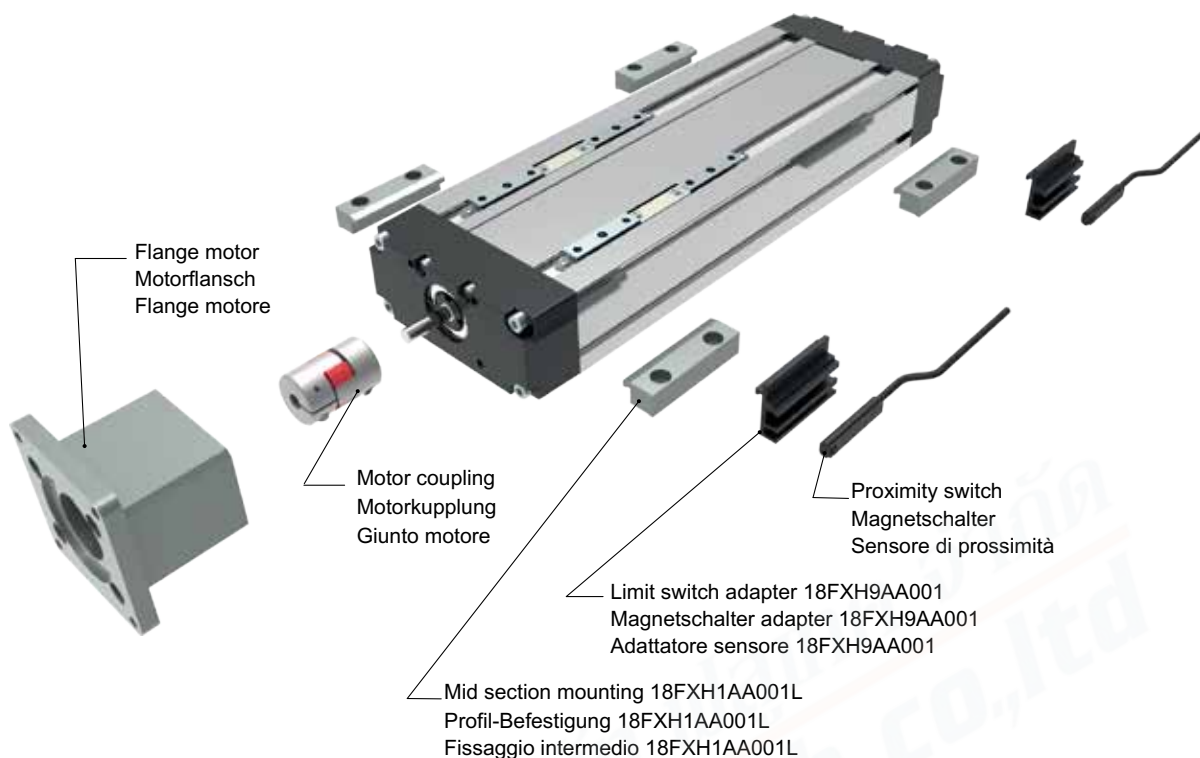

## ORDERING INFORMATION | Bestellangaben Baureihe | Codici per l'ordinazione

### Proximity switch

### Magnetschalter

### Sensore di prossimità

Part nr.   Ident nr.   Cod.	Cable   Kabel   Cavo	Output   Ausgangsfunktion   Uscita
1580.HAP	with 2,5 mt cable - NO   mit 2,5 mt Kabel - NO   con cavo 2,5 mt - NA	PNP, Hall
1580.HAN	with 2,5 mt cable - NO   mit 2,5 mt Kabel - NO   con cavo 2,5 mt - NA	NPN, Hall
MHS.P	300 mm with M8 plug in   mit 300 mm Kabel und M8 Stecker   300 mm conn. M8	PNP, Hall

For the technical characteristics, see the General Catalogue, Section 6 "Magnetic sensors" | Die Eigenschaften von Sensoren sind im allgemeinen Katalog, Abschnitt 6 "magnetische Sensoren dargestellt" | Per le caratteristiche dei sensori, vedi il Catalogo Generale, Sezione 6 "Sensori magnetici"

## 18TUK50.0500.A.R.A

**Stroke mm**  
Hub mm  
Corsa mm

**Shaft** | Versionen Antriebeswelle | Versione Albero

A: Without key shaft | Ohne Passfeder | Senza chiavetta  
B: With key shaft | Mit Passfeder | Con sede chiavetta

**Screw pitch / N. Carriages**

Spindelsteigung / Anzahl Wagen  
Passo vite / Numero carrelli  
A = 5 mm / n° 1  
B = 5 mm / n° 2  
C = 10 mm / n° 1  
D = 10 mm / n° 2  
E = 16 mm / n° 1  
F = 16 mm / n° 2

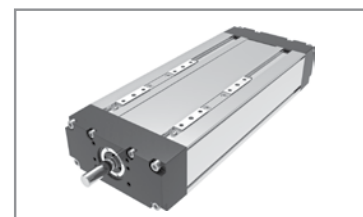
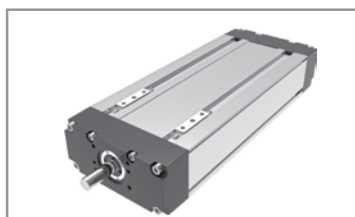

## 18TUK65 Series Baureihe 18TUK65 | Serie 18TUK65

### Screw driven guided linear unit

Linearantrieb mit Rundspindel und integrierter Kugelumlaufführung  
Attuatori lineari a vite e guida a ricircolo di sfere

Carriages Laufwagen Carrelli	Max stroke Max Hub Corsa max	Min stroke Min Hub Corsa min	Pitch Steigung Passo vite	Ø screw Ø gewinde Ø vite	Base weight Grundmasse Peso base	Add for 100 mm Masse pro 100 mm Hub Peso ogni 100 mm	Inertia moment Ix Flächenträgheitsmoment Momento d'inerzia Ix	Inertia moment Iy Flächenträgheitsmoment Momento d'inerzia Iy
	mm	mm	mm	mm	kg	kg	cm <sup>4</sup>	cm <sup>4</sup>
1	1500	--	5	20	2,8	0,75	90	687
			10					
			20					
2	1500	--	5	20	4,1	0,75	90	687
			10					
			20					

Carriages Laufwagen Carrelli	Pitch Steigung Passo vite	Max Fx*	Max Fy*	Max Fz*	Max Mx*	Max My*	Max Mz*
		N	N	N	Nm	Nm	Nm
1	5	3597	8500	8500	550	330	330
	10	2996					
	20	1798					
2	5	3597	11200	11200	950	1150	1150
	10	2996					
	20	1798					

\* The moments and the loads above are max. values. For any further information, please contact our technical department.

\* Die angegebenen Momente und Belastungen sind max. Werte, die nicht überschritten werden sollen. Für weitere Informationen wenden Sie sich bitte an unser Konstruktionsbüro.

\* I carichi e i momenti indicati sono massimi consigliati, per ulteriori informazioni consultare il ns ufficio tecnico.

$$\frac{F_{yA}}{F_y} + \frac{F_{zA}}{F_z} + \frac{M_{xA}}{M_x} + \frac{M_{yA}}{M_y} + \frac{M_{zA}}{M_z} \leq 1$$

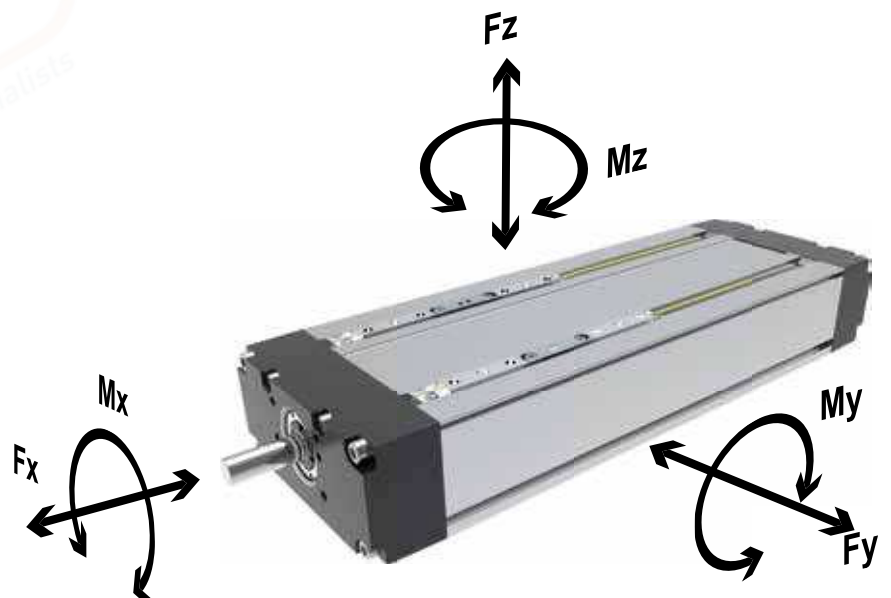



# 18TUK65 Series Baureihe 18TUK65 | Serie 18TUK65

ELECTRIC ACTUATION - ELEKTRISCHE ANTRIEBE - ATTUAZIONE ELETTRICA

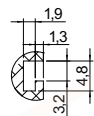
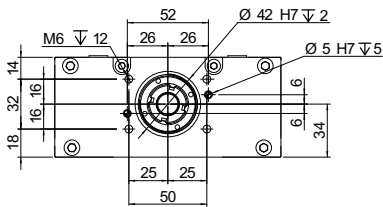
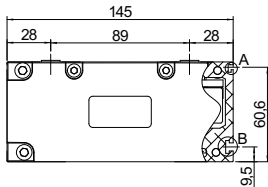
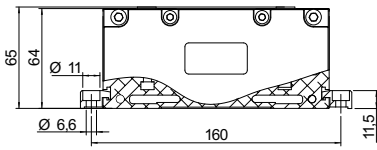

View A  
Ansicht A  
Vista A

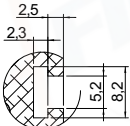

View B  
Ansicht B  
Vista B

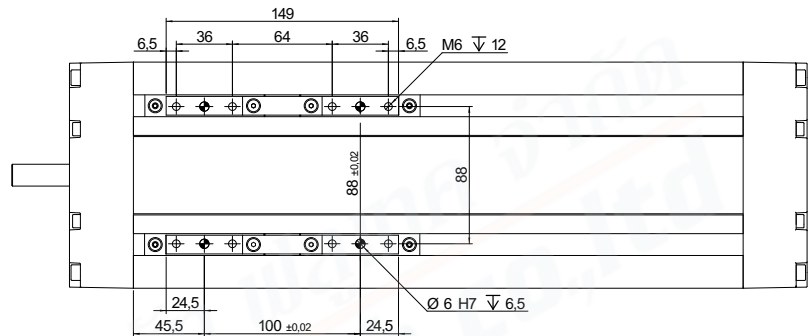
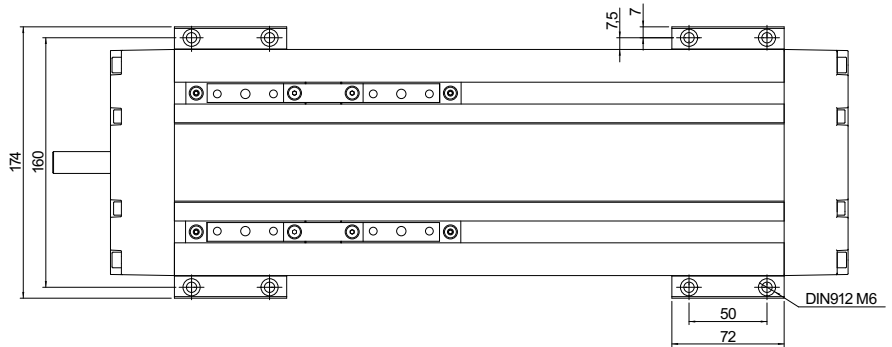

Double Carriage  
Tandem-Wagen  
Doppio Carrello

Stroke + 273  
Hub + 273  
Corsa + 273

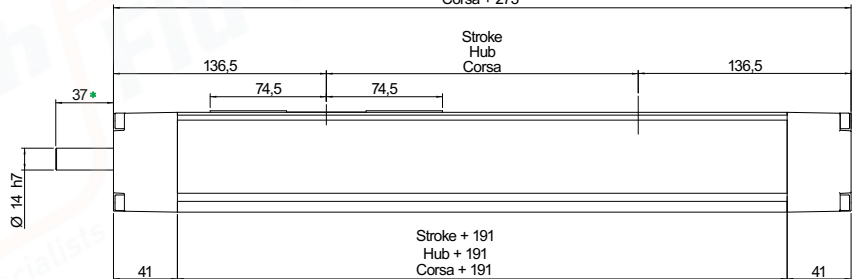

Stroke + 191  
Hub + 191  
Corsa + 191

Single Carriage  
Uno-Wagen  
Carrello Singolo

Stroke + 173  
Hub + 173  
Corsa + 173

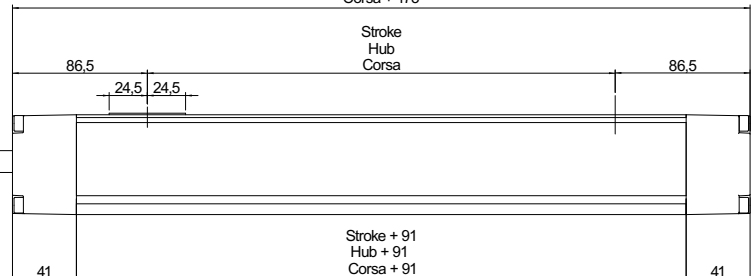

Stroke + 91  
Hub + 91  
Corsa + 91

*Measure likely to change according to customer request  
Messen sich wahrscheinlich ändern nach Kundenwunsch  
Misura suscettibile di modifica su richiesta del cliente*

# 18TUK65 Series Baureihe 18TUK65 | Serie 18TUK65

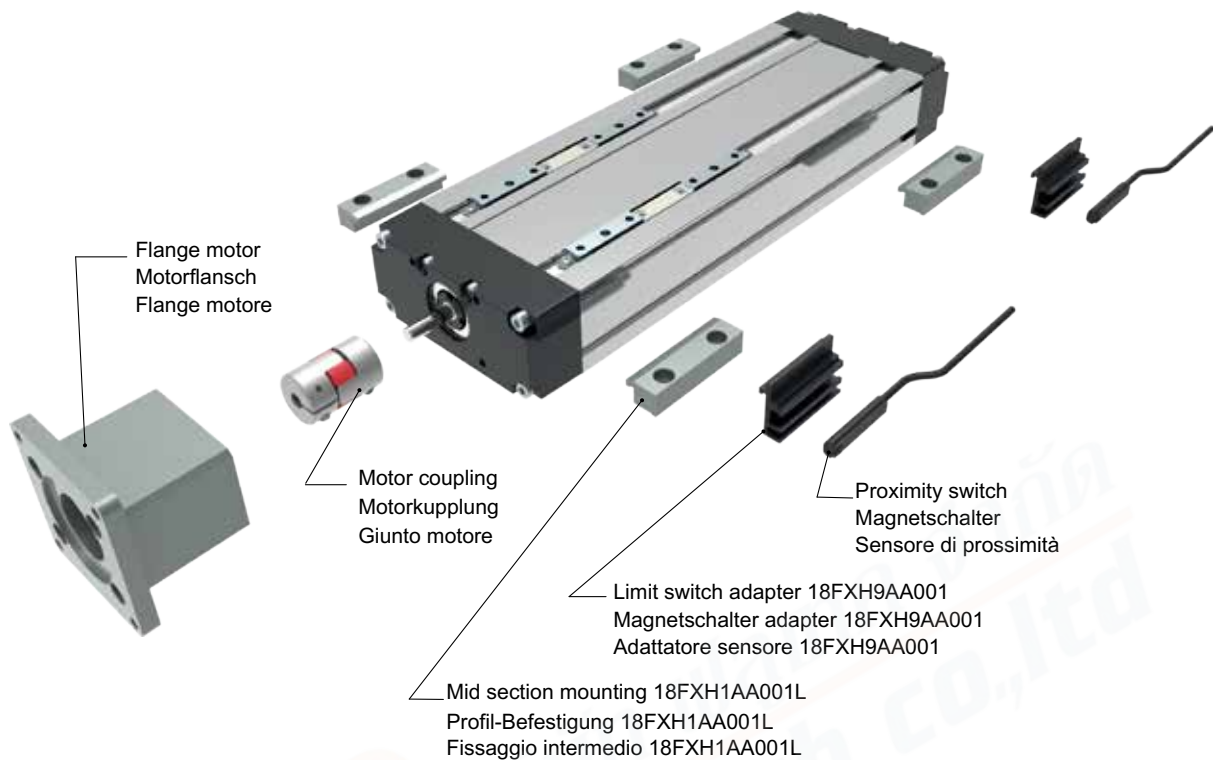

## ORDERING INFORMATION | Bestallangaben Baureihe | Codici per l'ordinazione

Proximity switch		Magnetschalter	Sensore di prossimità
Part nr.   Ident nr.   Cod.	Cable   Kabel   Cavo	Output   Ausgangsfunktion   Uscita	
1580.HAP	with 2,5 mt cable - NO   mit 2,5 mt Kabel - NO   con cavo 2,5 mt - NA	PNP, Hall	
1580.HAN	with 2,5 mt cable - NO   mit 2,5 mt Kabel - NO   con cavo 2,5 mt - NA	NPN, Hall	
MHS.P	300 mm with M8 plug in   mit 300 mm Kabel und M8 Stecker   300 mm conn. M8	PNP, Hall	

For the technical characteristics, see the General Catalogue, Section 6 "Magnetic sensors" | Die Eigenschaften von Sensoren sind im allgemeinen Katalog, Abschnitt 6 "magnetische Sensoren dargestellt" | Per le caratteristiche dei sensori, vedi il Catalogo Generale, Sezione 6 "Sensori magnetici"

## 18TUK65.0500.A.R.A

**Stroke mm**  
Hub mm  
Corsa mm

**Screw pitch / N. Carriages**

Spindelsteigung / Anzahl Wagen  
Passo vite / Numero carrelli  
A = 5 mm / n° 1  
B = 5 mm / n° 2  
C = 10 mm / n° 1  
D = 10 mm / n° 2  
E = 20 mm / n° 1  
F = 20 mm / n° 2

**Shaft | Versionen Antriebeswelle | Versione Albero**

A: Without key shaft | Ohne Passfeder | Senza chiavetta  
B: With key shaft | Mit Passfeder | Con sede chiavetta

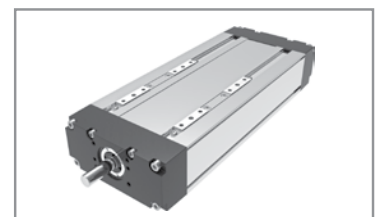



## 18TL155 Series Baureihe 18TL155 | Serie 18TL155

### Screw driven guided linear unit

Linearantrieb mit Rundspindel und integrierter Kugelumlaufführung

Unità a vite e guida a ricircolo di sfere

#### TECHNICAL DATA | TECHNISCHE DATEN | DATI TECNICI

Size - Baugröße - Taglia			155x60		
Max. speed* - Max. Geschwindigkeit* - Velocità max*	m/s		1,25*		
Max. stroke length - Max. Hub - Corsa max	mm	1000	1250	1500	
Min. stroke length - Min. Hub - Corsa min	mm	100	100	100	
Pitch - Spindelsteigung - Passo vite	mm	5	10	16	
Screw diameter - Spindeldurchmesser - Diametro vite	mm	16			
Base weight - Gewicht bei 0mm Hub - Peso corsa 0 mm	Kg	5,9			
Add for 100 mm of stroke - Gewicht bei 100mm Hub - Peso corsa 100 mm	Kg	1,15			
Max. load** - Max. Belastung ** - Carico max**	Fx	N	7851	7023	7400
	Fy	N	4200		
	Fz	N	4200		
Moments* - Max. Belastungsmoment* - Momenti max*	Mx	Nm	280		
	My	Nm	450		
	Mz	Nm	400		
Inertia moment Aluminum profile - Flächenträgheitsmoment - Momento d'inerzia profilo	Ix	cm <sup>4</sup>	563,6		
Inertia moment Aluminum profile - Flächenträgheitsmoment - Momento d'inerzia profilo	Iy	cm <sup>4</sup>	600,5		
Repeatability - Wiederholgenauigkeit - Ripetibilità	mm	± 0,02			
Screw class - klasse Kugelgewinde - Classe vite**	T7				
No load torque - Leerlaufmoment - Coppia resistente	Nm	0,3	0,2	0,15	

\* It depends from stroke and the spindle pitch

\* In Abhängigkeit von Hub und Spindelsteigung

\* Valore indicativo, dipende dalla corsa e dal passo vite

\*\* Max values for dynamic conditions. Please refer to the following formula when combined loads are applied.

\*\* Für die Ermittlung der maximalen dynamischen Tragzahlen bei kombinierten Kraftangriffspunkten, nutzen Sie bitte die nebenstehende Berechnungsformel.

\*\* Valori massimi in condizioni dinamiche. In presenza di carichi combinati riferirsi alla formula per la verifica dei carichi massimi da applicare.

$$\frac{F_{yA}}{F_y} + \frac{F_{zA}}{F_z} + \frac{M_{xA}}{M_x} + \frac{M_{yA}}{M_y} + \frac{M_{zA}}{M_z} \leq 1$$

The A letters show the calculated value.

Der A Parameter entspricht dem errechneten Wert.

La lettera A indica i valori complessivi calcolati

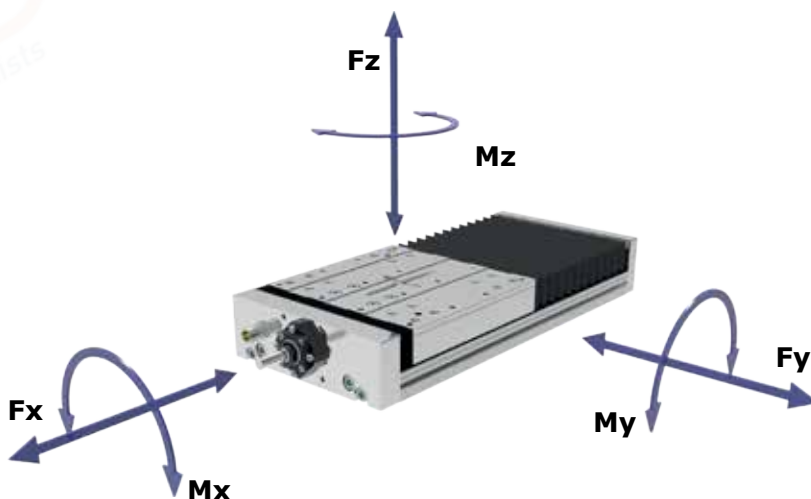

# 18TL155 Series Baureihe 18TL155 | Serie 18TL155

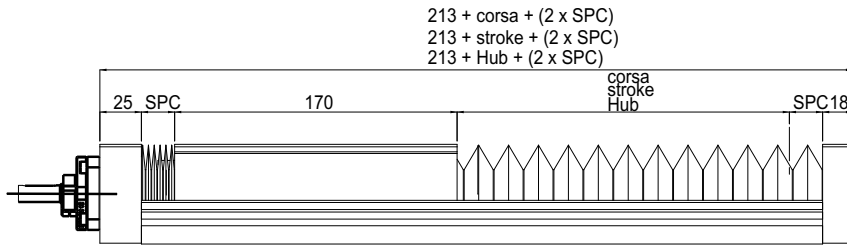

Please contact the technical department for the A and SPC dimensions  
 Bitte wenden Sie sich an unsere technische Abteilung  
 Per le quote A e SPC contattare il nostro ufficio tecnico

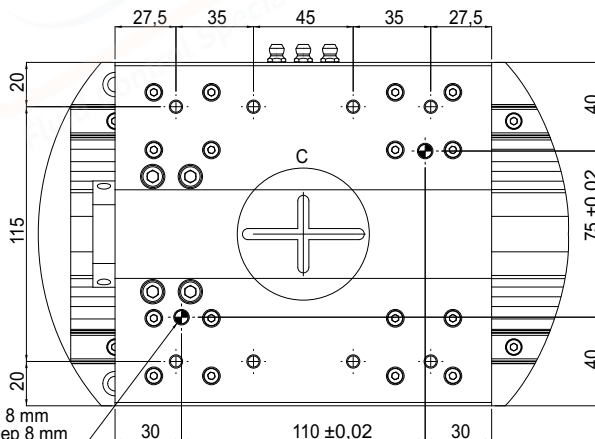
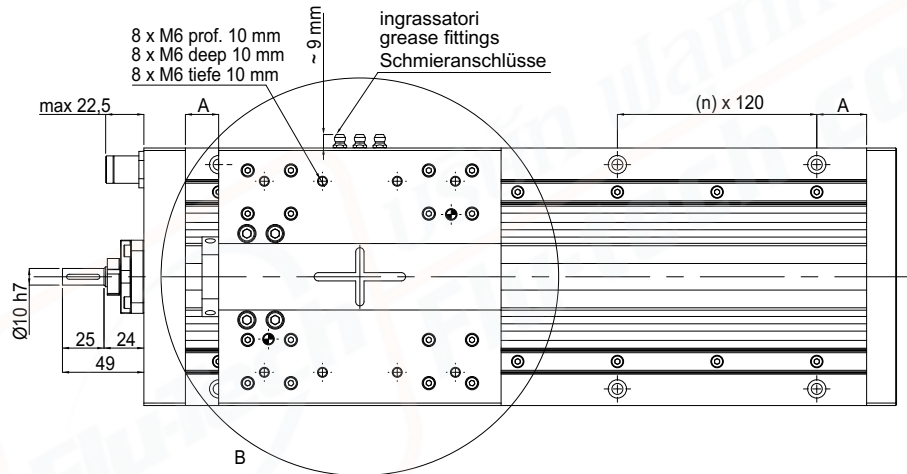
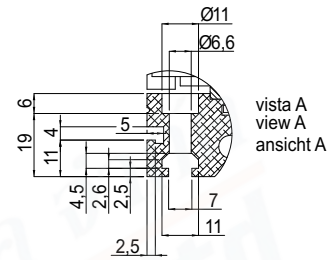
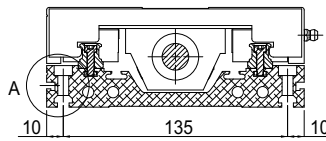
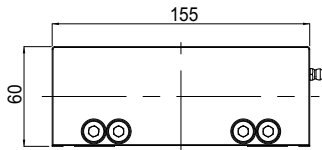
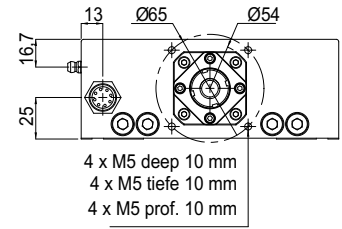

foro spina Ø6 H7 prof. 8 mm  
 dowel holes Ø6 H7 deep 8 mm  
 stiftbohrung Ø6 H7 tiefe 8 mm

vista B  
 view B  
 ansicht B

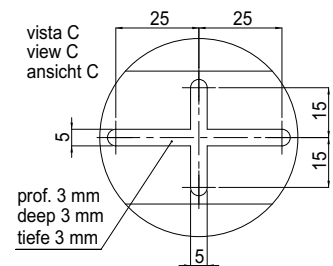



## 18TL155 Series Baureihe 18TL155 | Serie 18TL155

ELECTRIC ACTUATION - ELEKTRISCHE ANTRIEBE - ATTUAZIONE ELETTRICA

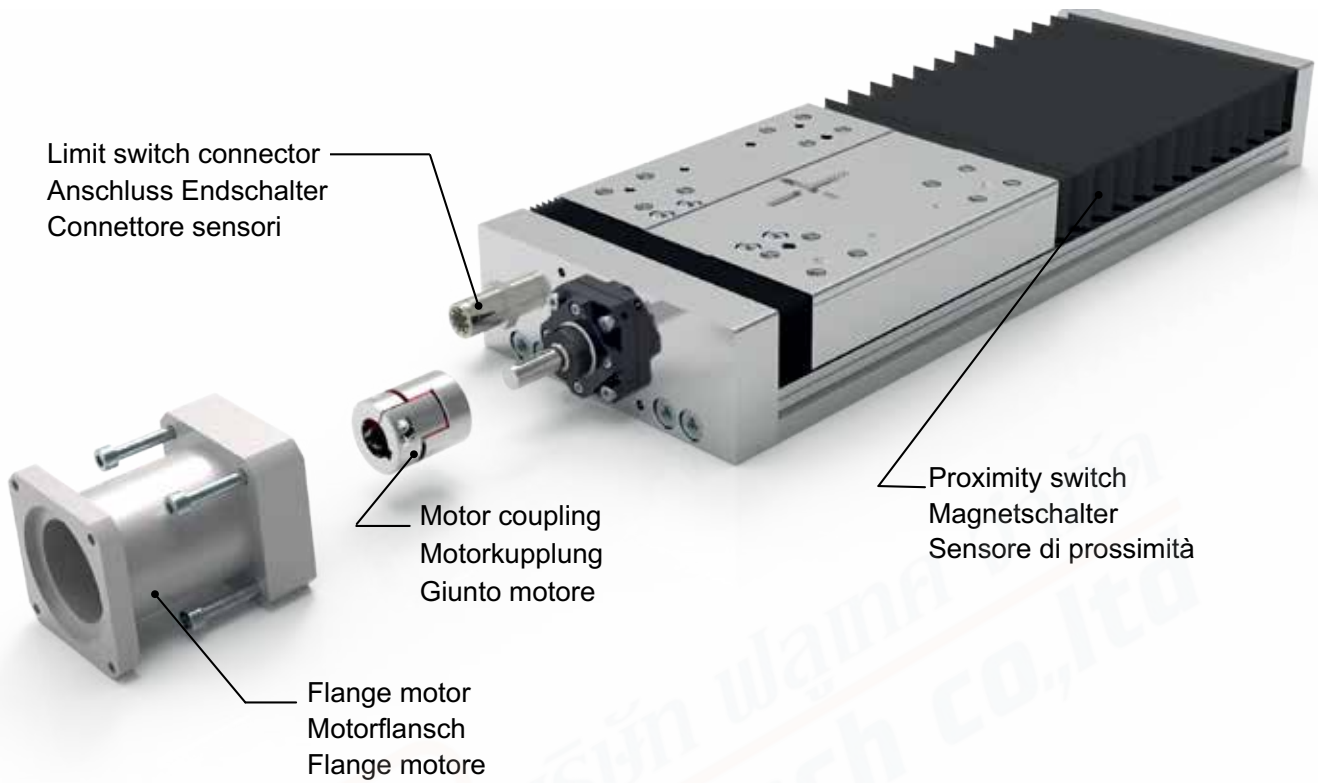

### ORDERING INFORMATION | Bestallangaben Baureihe | Codici per l'ordinazione

## 18TL 155.0500.A.A.1

**Stroke mm**  
Hub mm  
Corsa mm

**Screw pitch**  
Spindelsteigung  
Passo vite  
A = 5 mm  
B = 10 mm  
C = 16 mm

**Shaft** | Versionen Antriebeswelle | Versione Albero

0: Without limit switch | Ohne Magnetschalter | Senza sensori  
1: With limit switch | Mit Magnetschalter | Con sensori

**Bellows** | Balg | Soffiretti

A: With Bellows | Mit Balg | Con soffiatti  
0: Without bellows | Ohne Balg | Senza soffiatti

## 18TL225 Series Baureihe 18TL225 | Serie 18TL225

### Screw driven guided linear unit

Linearantrieb mit Rundspindel und integrierter Kugelumlauführung

Unità a vite e guida a ricircolo di sfere

#### TECHNICAL DATA | TECHNISCHE DATEN | DATI TECNICI

Size - Baugröße - Taglia			225x75		
Max. speed* - Max. Geschwindigkeit* - Velocità max*	m/s		1,5*		
Max. stroke length - Max. Hub - Corsa max	mm	1000	1250	1500	
Min. stroke length - Min. Hub - Corsa min	mm	100	100	100	
Pitch - Spindelsteigung - Passo vite	mm	5	10	20	
Screw diameter - Spindeldurchmesser - Diametro vite	mm	20			
Base weight - Gewicht bei 0mm Hub - Peso corsa 0 mm	Kg	10,4			
Add for 100 mm of stroke - Gewicht bei 100mm Hub - Peso corsa 100 mm	Kg	1,6			
Max. load** - Max. Belastung ** - Carico max**	Fx	N	11000	11200	10500
	Fy	N	9200		
	Fz	N	9200		
Moments* - Max. Belastungsmoment* - Momenti max*	Mx	Nm	670		
	My	Nm	560		
	Mz	Nm	670		
Inertia moment Aluminum profile - Flächenträgheitsmoment - Momento d'inerzia profilo	Ix	cm <sup>4</sup>	2208		
	Iy	cm <sup>4</sup>	2322,6		
Repeatability - Wiederholgenauigkeit - Ripetibilità	mm	± 0,02			
Screw class - klasse Kugelgewinde - Classe vite**		T7			
No load torque - Leerlaufmoment - Coppia resistente	Nm	0,3	0,25	0,2	

\* It depends from stroke and the spindle pitch

\* In Abhängigkeit von Hub und Spindelsteigung

\* Valore indicativo, dipende dalla corsa e dal passo vite

\*\* Max values for dynamic conditions. Please refer to the following formula when combined loads are applied.

\*\* Für die Ermittlung der maximalen dynamischen Tragzahlen bei kombinierten Kraftangriffspunkten, nutzen Sie bitte die nebenstehende Berechnungsformel.

\*\* Valori massimi in condizioni dinamiche. In presenza di carichi combinati riferirsi alla formula per la verifica dei carichi massimi da applicare.

$$\frac{F_{yA}}{F_y} + \frac{F_{zA}}{F_z} + \frac{M_{xA}}{M_x} + \frac{M_{yA}}{M_y} + \frac{M_{zA}}{M_z} \leq 1$$

The A letters show the calculated value.

Der A Parameter entspricht dem errechneten Wert.

La lettera A indica i valori complessivi calcolati

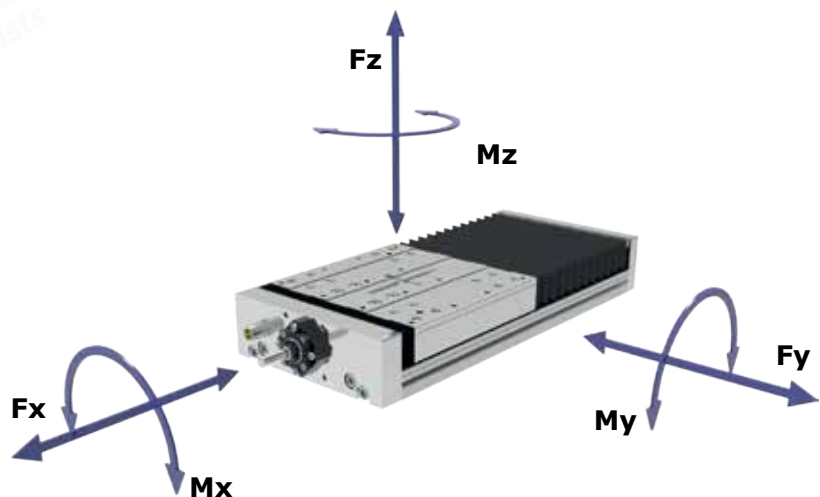



# 18TL225 Series Baureihe 18TL225 | Serie 18TL225

270 + corsa + (2 x SPC)  
270 + stroke + (2 x SPC)  
270 + Hub + (2 x SPC)

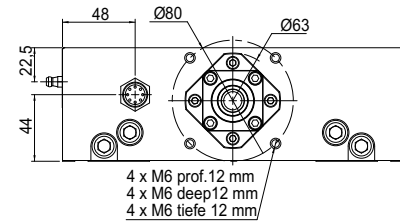
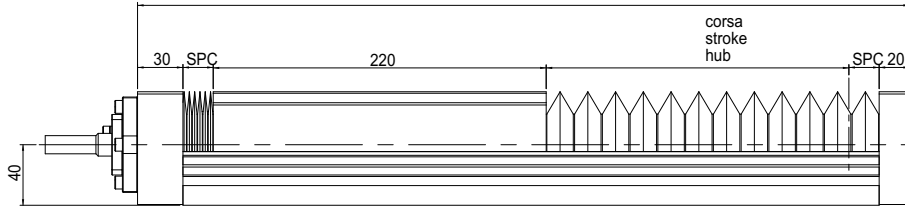

Per le quote A e SPC contattare il nostro ufficio tecnico  
Please contact the technical department for the A and SPC dimensions  
Bitte wenden Sie sich an unsere technische Abteilung

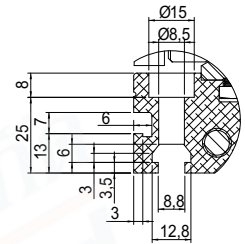
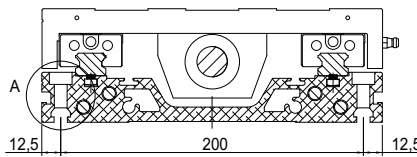
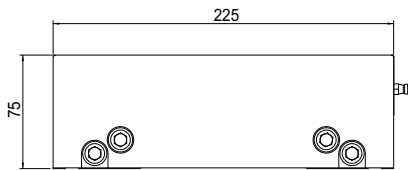

vista A  
view A  
ansicht A

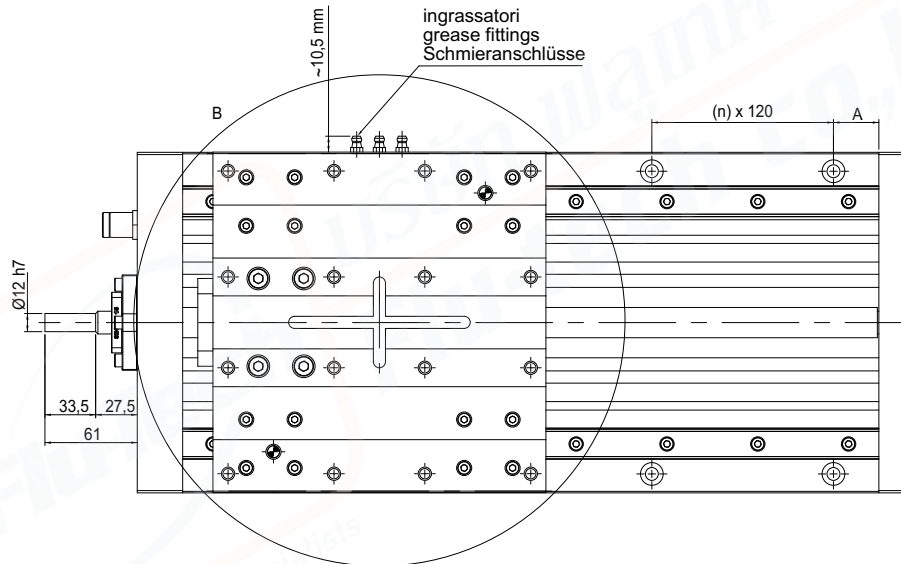

16 x M8 prof. 12 mm  
16 x M8 deep 12 mm  
16 x M8 tiefe 12 mm

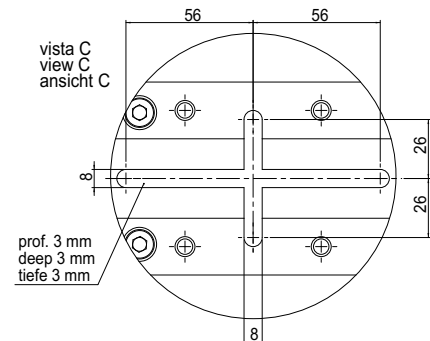
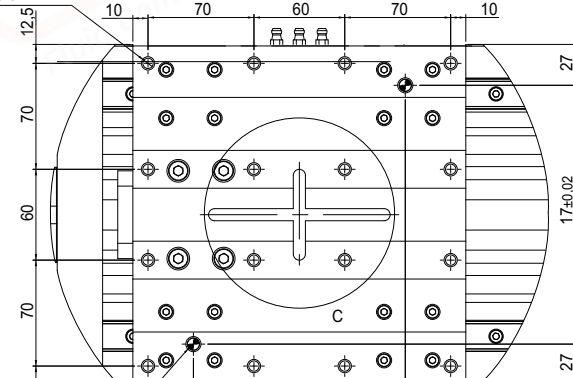

## 18TL225 Series Baureihe 18TL225 | Serie 18TL225

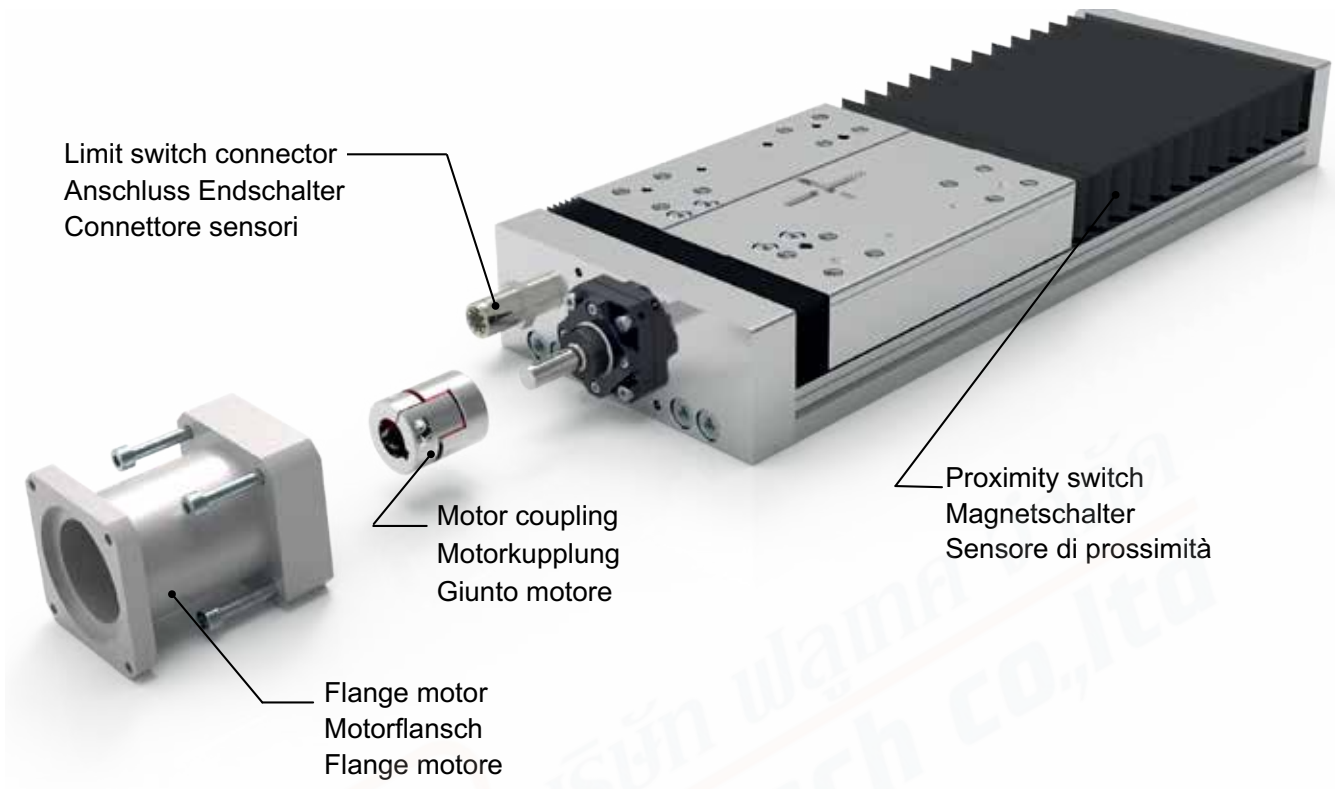

### ORDERING INFORMATION | Bestallangaben Baureihe | Codici per l'ordinazione

## 18TL 225.0500.A.A.1

#### Stroke mm

Hub mm  
Corsa mm

#### Screw pitch

Spindelsteigung  
Passo vite  
A = 5 mm  
B = 10 mm  
C = 20 mm

#### Shaft | Versionen Antriebeswelle | Versione Albero

0: Without limit switch | Ohne Magnetschalter | Senza sensori  
1: With limit switch | Mit Magnetschalter | Con sensori

#### Bellows | Balg | Soffiretti

A: With Bellows | Mit Balg | Con soffiatti  
0: Without bellows | Ohne Balg | Senza soffiatti



บริษัท ฟลูเทค จำกัด  
FLU-TECH CO.,LTD

845/3-4 หมู่ 3 ถ.เทพารักษ์ ต.เทพารักษ์ อ.เมือง จ.สมุทรปราการ 10270  
845/3-4 Thepharak RD., T.Thepharak, A.Muang, Samutprakarn 10270 THAILAND  
Tel. 0 2384 6060, Fax 0 2384 5701, Email : sales@flutech.co.th, www.flutech.co.th