

F300 Series, Solenoid valves for fluids

General details

PNEUMAX offer a vast range of solenoid valves in brass and stainless steel designed to control air, water, steam and all fluids that are compatible with the materials (body and seals) used in the range. The solenoid valves are 2 or 3-way, normally closed, normally open, general service, direct acting or servo-actuated, with connections available in NPT & BSP threads from G1/8" up to G2", with a working pressure range from vacuum to 100 bar. Solenoid valves are available with coils that conform to CESI 03 ATEX 344 certification for explosive environments. Our technical office ensures the highest standard of skill and understanding for the widest variety of applications, ensuring that the best possible solutions are found.

Versions manufactured

Direct action 2-way: 2-way solenoid valves have an input connection and an output connection machined in the valve body, the orifice being intercepted by the plunger mounted in the core tube.

They can be **normally closed (2/2 NC)**, in this case the fluid is intercepted by the plunger at rest, with electricity applied, the input orifice is opened and the media reaches the intended use.

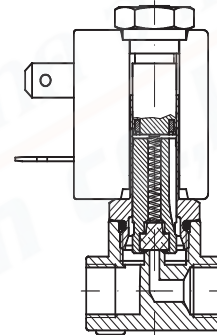

They can be **normally open (2/2 NO)**, in this case at rest the orifice remains open without electricity applied, the media reaches the intended use. When electricity is applied the input orifice closes.

Performance in both cases depends solely on the magnetic field produced by the solenoid coil.
The solenoid valves can also work at zero pressure.

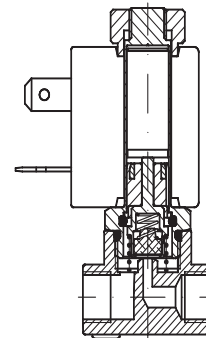

Direct action 3-way: 3-way solenoid valves have an input and an output connection in the valve body and an exhaust connection fitted in the fixed core. The input and exhaust orifices are intercepted directly by the plunger fitted within the core tube.

They can be **normally closed (3/2 NC)** and in this case, at rest, the incoming fluid is intercepted by the plunger and output port is connected to the exhaust port. Applying electrical power, the input orifice is opened and feed is supplied to the output. Exhaust is closed.

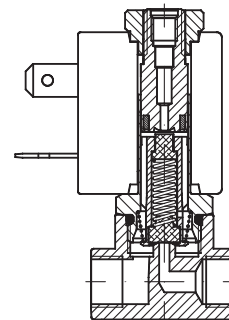

They can be **normally open (3/2 NA)** and in this case, at rest, the input orifice is open without electricity applied, the media reaches the intended use. Exhaust is closed. Applying power, the input orifice closes and the output discharges through the exhaust port.

Performance in both cases depends solely on the magnetic field produced by the solenoid coil.
The solenoid valves can also work at zero pressure.

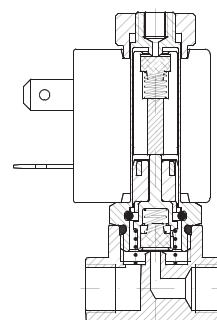

Servo actuated

With large-sized passage orifices, the static pressure value that needs to be overcome by the magnetic field produced by the coil increases.

These solenoid valves are used to control high-pressure values with large diameter bores. In these models, the fluid helps in the opening or closing of the main plunger.

They can be normally closed (2/2 NC) and have an input and a utilisation connection machined into the valve body and at rest the fluid is intercepted by the main plunger, which can be either diaphragm or a piston. In this condition, the fluid acts on both faces of the main plunger through a pinhole contributing to closure of the plunger.

Applying electrical power, the secondary, or pilot, orifice opens leading to the exhaust of the fluid, which acts to close the main plunger. Greater force is thus applied when opening, the plunger is raised from the orifice and allows the media to flow to the output.

In these versions, performance does not depend solely on the magnetic field produced by the coil; a minimum input pressure is also needed so as to move the diaphragm or the piston overcoming its rigidity and to keep it raised from the main orifice. (Δp minimum performance).

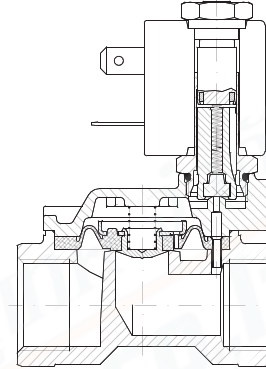

They can be **normally open (2/2 NA)**, and have an input and output connection machined into the valve body, and at rest the secondary plunger communicates with output, a minimum-pressure difference between the feed and the output causes the main shutter to rise, leading to it opening.

Applying electrical power, the secondary orifice closes and equilibrium between the pressure on the two faces of the main shutter is reinstated, and so it returns to its closed position on the main orifice.

In this version a minimum working pressure is also needed.

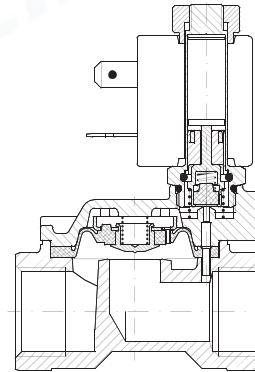

Sealing materials

Designation	Trade names	General characteristics	Field of use
FPM (Fluorocarbon)	VITON TECNOFロン FLUOREL	A synthetic hexa-fluoropropylene-based elastomer. Excellent resistance to high temperatures. Excellent resistance to ozone, oxygen, mineral oils, synthetic hydraulic fluids, fuels, hydrocarbons and many chemical products. Not specific for superheated steam.	For general use up to 130 °C

Resistance to fluids

The table below serves to general information relating to the compatibility between FPM (fluorocarbon) and a number of neutral fluids. Where there are corrosive fluids, in order to establish compatibility, it is important to be aware of all the data relating to use: temperature, concentration and composition of the fluid.

Fluido	
Ethyl acetate	Non Compatible
Acetylene	Compatible
Vinegar	Non Compatible
Acetone	Non Compatible
Calcareous water	Compatible
Hot water <75°C	Compatible
Hot water and steam <140°C	Non Compatible
Water with glycol	Compatible
Deionised water	Compatible
Demineralised water	Compatible
Hydrogen peroxide	Compatible
Soapy water	Compatible
Carbon dioxide (liquid)	Non Compatible
Dry carbon dioxide (gas)	Compatible
Argon	Compatible
Nitrogen	Compatible
Petrol/Gasoline	Compatible
Benzol	Non Compatible
Butane	Compatible
Chloroform	Non Compatible
Ethyl Chloride	Compatible
Methyl chloride	Non Compatible
Helium	Compatible
Heptane	Compatible
Hexane	Compatible
Ethane	Compatible
Ethanol	Non Compatible
Formaldehyde	Compatible
Freon	Non Compatible
Natural gas	Compatible
Diesel oil	Compatible
Glycerine	Compatible
Ethylene glycol	Compatible
Hydrogen	Compatible
Isobutane	Compatible
Isopentane	Compatible
Methane	Compatible
Methanol	Non Compatible
Calcium monoxide	Compatible
Neon	Compatible
Nitrobenzene	Non Compatible
Mineral oil	Compatible
Oxygen	Compatible
Pentane-n	Compatible
Propanol-n	Compatible
Propane-n	Compatible
Carbon sulphide	Non Compatible
Toluene	Compatible
Dry trichloroethylene	Compatible
Xylene	Compatible

► 2-way solenoid normally closed valve, direct plunger operation

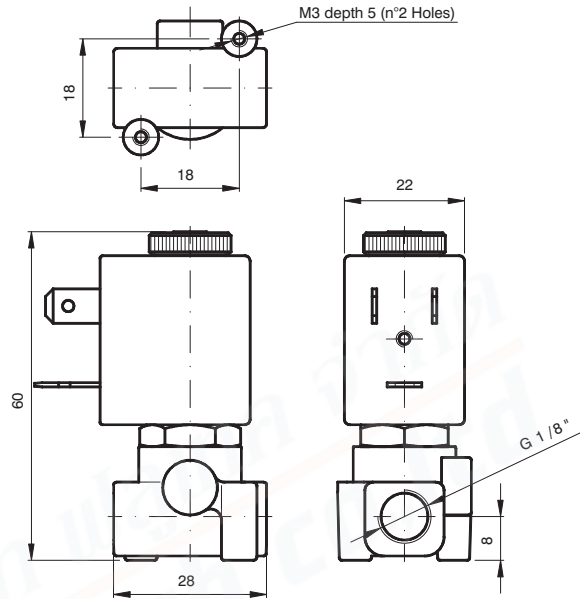

CODE	Connection G ISO 228	Orifice (mm)	KV (m ³ /h)	Differential pressure (bar)			Power Consumption			Coil ②		Temp. range (°C)
				Min	Max		AC Inrush	VA Holding	DC Watt	Series	Size	
					AC	DC						
F3105AV25②	1/8"	2,5	0,14	0	8	5,5	12	8	6,5	MI	22	-10 +130

N.B. For use with steam, maximum admitted pressure PS is 6 bar (relative pressure) with seals in FPM
Esempio: F3105AV25② => F3105AV25MI58:

2-way normally closed, direct acting solenoid valve with G connector (ISO228) 1/8", Seals in FPM, Orifice 2,5 mm, Coil 220V 50/60Hz (MI58, size 22).

Pneumatic symbol

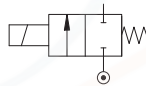

Diagram

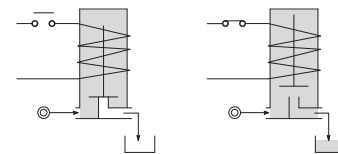

Operational characteristic

- Brass Body
- Guide pipe in Brass
- Mobile and fixed core in Stainless Steel
- Springs in Stainless Steel
- Sealing assemblies in FPM

- OPTIONS (if requested):

- Manual operation
- Surface treatment in chemical nickel-plating
- Guide pipe in Stainless Steel
- For use with oxygen

Technical characteristic

Maximum admitted pressure (bar)	50
Maximum fluid viscosity (mm ² /s)	25cSt
Ambient temperature: with class F coil (°C)	-10 +55
Mounting position	indifferent
Weight (gr.) with MI Series Coil	130

► 2-way solenoid normally closed valve, direct plunger operation

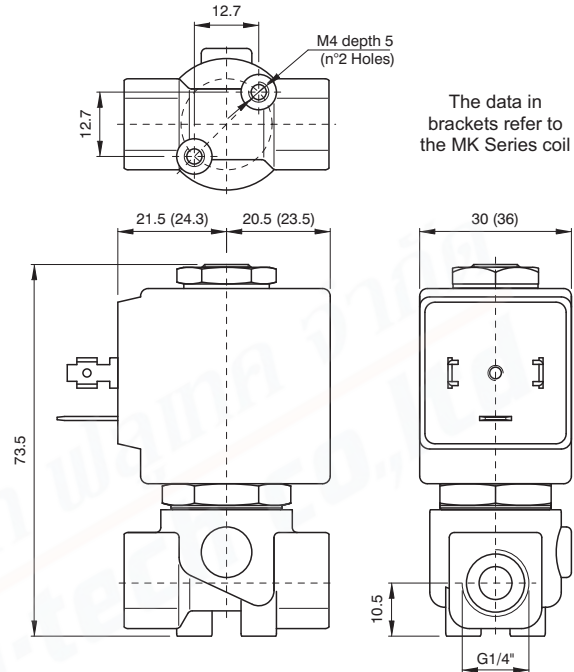

CODE "V" = Seals in FPM "E" = Coil	Connection G ISO 228	Orifice (mm)	KV (m³/h)	Differential pressure (bar)			Power Consumption			Coil Ⓞ		Temp. range (°C)
				Min	Max		AC Inrush	VA Holding	DC Watt	Series	Size	
					AC	DC						
F3106BV15E	1/4"	1,5	0,07	0	30	26	20	15	10	MG	30	-10 +140
F3106BV20E	1/4"	2,0	0,1	0	22	20	20	15	10	MG	30	
F3106BV25E	1/4"	2,5	0,15	0	16	14	20	15	10	MG	30	
F3106BV35E	1/4"	3,5	0,32	0	10	8	20	15	10	MG	30	
F3106BV45E	1/4"	4,5	0,41	0	6,5	3,5	20	15	10	MG	30	
F3106BV52E	1/4"	5,2	0,47	0	4	1,8	20	15	10	MG	30	
F3106BV64E	1/4"	6,4	0,64	0	3	1	20	15	10	MG	30	
F3106BV15E	1/4"	1,5	0,07	0	80	80	40	30	27	MK	36	
F3106BV20E	1/4"	2,0	0,1	0	50	40	40	30	27	MK	36	
F3106BV25E	1/4"	2,5	0,15	0	35	33	40	30	27	MK	36	
F3106BV35E	1/4"	3,5	0,32	0	20	19	40	30	27	MK	36	
F3106BV45E	1/4"	4,5	0,41	0	14	13	40	30	27	MK	36	
F3106BV52E	1/4"	5,2	0,47	0	10	9	40	30	27	MK	36	
F3106BV64E	1/4"	6,4	0,64	0	5	4,5	40	30	27	MK	36	

N.B. For use with steam, maximum admitted pressure PS is 6 bar (relative pressure) with seals in PTFE and 2.5 bar with seals in EPDM.
Example: F3106BV52E => F3106BV52MG58:
2-way normally closed, direct acting solenoid valve with G connector (ISO228) 1/4", Seals in FPM, Orifice 5.2 mm, Coil 220V 50/60Hz (MG58, size 30).

Pneumatic symbol

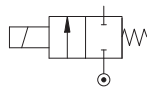

Diagram

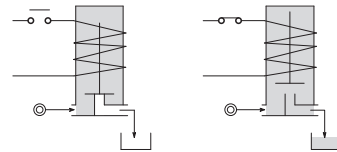

Operational characteristic

- Brass Body
- Guide pipe in Stainless Steel
- Mobile and fixed core in Stainless Steel
- Springs in Stainless Steel
- Sealing assemblies in FPM
- **OPTIONS (if requested):**
 - Manual operation
 - Surface treatment in chemical nickel-plating
 - Inserted stainless steel seating
 - For use with oxygen

Technical characteristic

Maximum admitted pressure (bar)	80
Maximum fluid viscosity (mm ² /s)	25cSt
Ambient temperature: with class F coil (°C)	-10 +55
Ambient temperature: with class H coil (°C)	-10 +80
Mounting position	indifferent
Weight (gr.) with MG Series Coil	300
Weight (gr.) with MK Series Coil	380

2-way solenoid normally closed valve, direct plunger operation

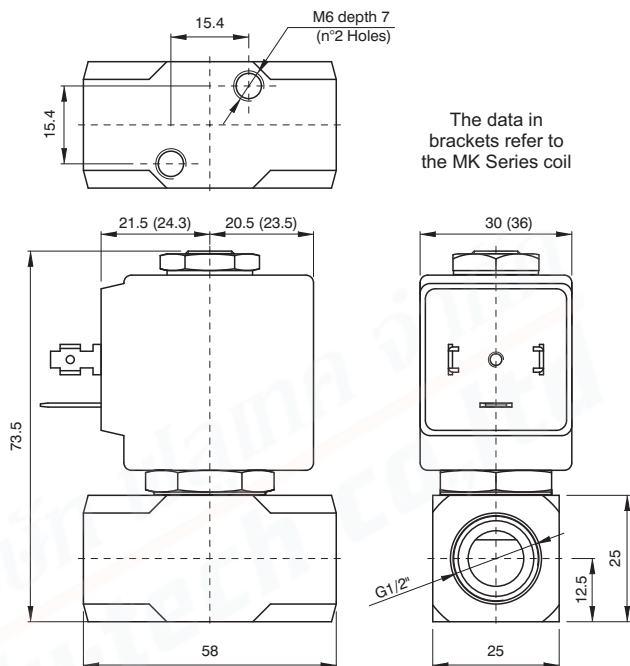

CODE	Connection G ISO 228	Orifice (mm)	KV (m³/h)	Differential pressure (bar)			Power Consumption			Coil Ⓢ		Temp. range (°C)
				Min	Max		AC Inrush	VA Holding	DC Watt	Series	Size	
					AC	DC						
F3106DV45Ⓢ	1/2"	4,5	0,41	0	6,5	3,5	20	15	10	MG	30	-10 +140
F3106DV52Ⓢ	1/2"	5,2	0,47	0	4	1,8	20	15	10	MG	30	
F3106DV64Ⓢ	1/2"	6,4	0,64	0	3	1	20	15	10	MG	30	
F3106DV45Ⓢ	1/2"	4,5	0,41	0	14	13	40	30	27	MK	36	
F3106DV52Ⓢ	1/2"	5,2	0,47	0	10	9	40	30	27	MK	36	
F3106DV64Ⓢ	1/2"	6,4	0,64	0	5	4,5	40	30	27	MK	36	

N.B. For use with steam, maximum admitted pressure PS is 6 bar (relative pressure) with seals in PTFE and 2.5 bar with seals in EPDM.

Example: F3106DV52Ⓢ => F3106DV52MK5:

2-way normally closed, direct acting solenoid valve with G connector (ISO228) 1/2". Seals in FPM, Orifice 5.2 mm, Coil 24V DC (MK5, size 36).

Pneumatic symbol

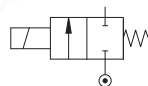

Diagram

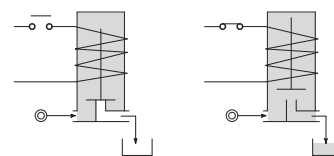

Operational characteristic

- Brass Body
- Guide pipe in Stainless Steel
- Mobile and fixed core in Stainless Steel
- Springs in Stainless Steel
- Sealing assemblies in FPM

- OPTIONS (if requested):

- Manual operation
- Surface treatment in chemical nickel-plating
- For use with oxygen

Technical characteristic

Maximum admitted pressure (bar)	80
Maximum fluid viscosity (mm ² /s)	25cSt
Ambient temperature: with class F coil (°C)	-10 +55
Ambient temperature: with class H coil (°C)	-10 +80
Mounting position	indifferent
Weight (gr.) with MG Series Coil	300
Weight (gr.) with MK Series Coil	380



► 2-Way normally closed solenoid valve, servo-actuated diaphragm

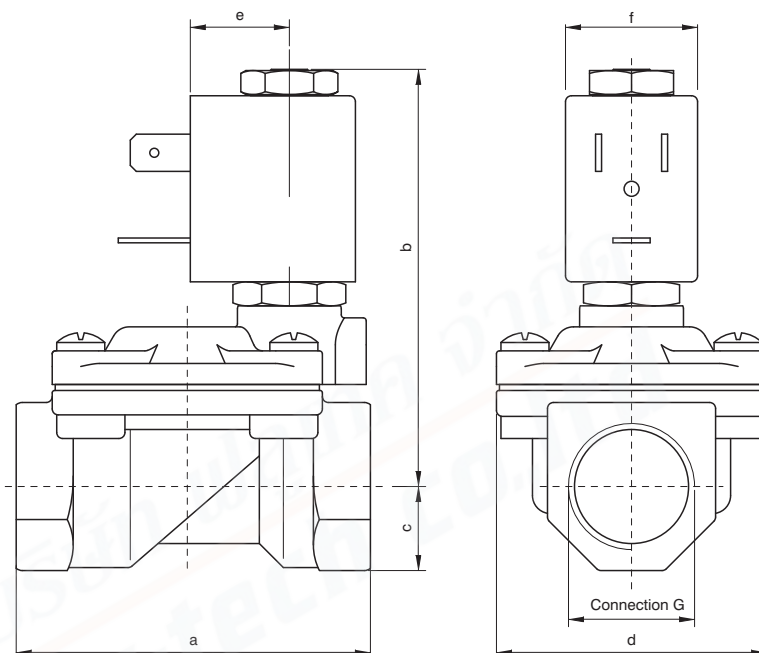

Connection	a	b	c	d	e	f	Weight (g)
G1/4" Ø10	49	65	11	32	16	22	230
G3/8" Ø12	59	70	14	45	16	22	420
G1/2" Ø12	59	70	14	45	16	22	390
G3/4"	79	76	18	55	16	22	650
G1"	96	85	20	72	16	22	1050
G1" 1/4	119	92	25	85	16	22	1700

CODE "V" = Seals in FPM ⊕ = Coil	Connection G ISO 228	Orifice (mm)	KV (m³/h)	Differential pressure (bar)			Power Consumption			Coil ⊕		Temp. range (°C)
				Min	Max		AC Inrush	VA Holding	DC Watt	Series	Size	
					AC	DC						
F3107BV10⊕	1/4"	10	1,5	0,15	15	15	12	8	6,5	MI	22	-10 +140
F3107CV12⊕	3/8"	12	2,2	0,15	15	15	12	8	6,5	MI	22	
F3107DV12⊕	1/2"	12	2,5	0,15	15	15	12	8	6,5	MI	22	
F3107EV18⊕	3/4"	18	5,5	0,15	13	13	12	8	6,5	MI	22	
F3107FV25⊕	1"	24	10,2	0,15	10	10	12	8	6,5	MI	22	
F3107GV30⊕	1" 1/4	30	15	0,15	10	10	12	8	6,5	MI	22	

N.B. For use with steam maximum admitted pressure PS is 2.5 bar (relative pressure)

Example: F3107BV10⊕ => F3107BV10MI5:

2-Way normally closed solenoid valve, servo-actuated diaphragm with Connector G (ISO228) 1/4", Seals in FPM, Orifice 10 mm, Coil 24V DC (MI5, size 22).

Pneumatic symbol

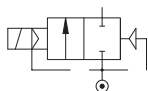

Diagram

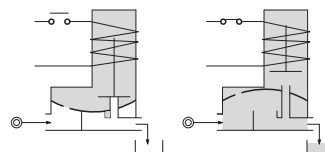

Operational characteristic

- Body and cover in Brass
- Guide pipe in Stainless Steel
- Mobile and fixed core in Stainless Steel
- Springs in Stainless Steel
- Sealing assemblies in FPM

- OPTIONS (if requested):

- Manual operation
- Surface treatment in chemical nickel-plating
- Coil for potentially explosive environments meeting "ATEX standards Ex m Serie XME".
- Version with slowed commutation
- Version for vacuum (air/gas)
- Version for use with oxygen
- "SVGW/SSIGE" approved versions.

Technical characteristic

Minimum differential pressure (bar)	0,15
Maximum admitted pressure (bar)	25
Maximum fluid viscosity (mm ² /s)	25cSt
Ambient temperature: with class F coil (°C)	-10 +55
Ambient temperature: with class H coil (°C)	-10 +80
Mounting position	Preferably with coil upwards

2-Way normally closed solenoid valve, servo-actuated diaphragm

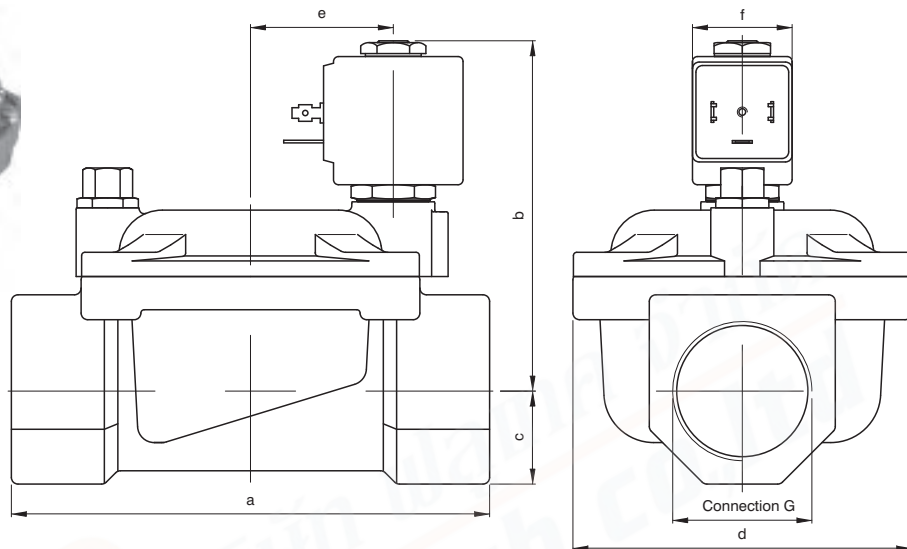

Connection	a	b	c	d	e	f	Weight (g)
G1" 1/4	142	105	28	102	21	30	3000
G1" 1/2	142	105	28	102	21	30	2850
G2"	158	115	35	119	21	30	4300

CODE "V"=Seals in FPM ⊗ = Coil	Connection G ISO 228	Orifice (mm)	KV (m³/h)	Differential pressure (bar)			Power Consumption			Coil ⊗		Temp. range (°C)
				Min	Max		AC Inrush	VA Holding	DC Watt	Series	Size	
					AC	DC						
F3107GV37⊗	1 1/4"	37	18	0,15	10	10	20	15	10	MG	30	-10 +140
F3107HV37⊗	1" 1/2"	37	21	0,15	10	10	20	15	10	MG	30	
F3107IV50⊗	2"	50	36	0,15	10	10	20	15	10	MG	30	

N.B. For use with steam maximum admitted pressure PS is 2.5 bar (relative pressure)

Example: F3107GV37⊗ => F3107GV37MG5:

2-Way normally closed solenoid valve, servo-actuated diaphragm with Connector G (ISO228) 1" 1/4", Seals in FPM, Orifice 37 mm, Coil 24V DC (MG5, size 30).

Pneumatic symbol

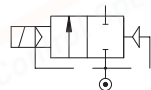

Diagram

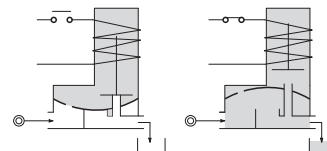

Operational characteristic

- Body and cover in Brass
- Guide pipe in Stainless Steel
- Mobile and fixed core in Stainless Steel
- Springs in Stainless Steel
- Sealing assemblies in FPM

- OPTIONS (if requested):

- Manual operation
- Surface treatment in chemical nickel-plating
- Version for vacuum (air/gas)

Technical characteristic

Minimum differential pressure (bar)	0,15 ÷ 3
Maximum admitted pressure (bar)	80
Maximum fluid viscosity (mm ² /s)	25cSt
Ambient temperature: with class F coil (°C)	-10 +55
Ambient temperature: with class H coil (°C)	-10 +80
Mounting position	Preferably with coil upwards



► 2-way solenoid normally closed valve, direct plunger operation

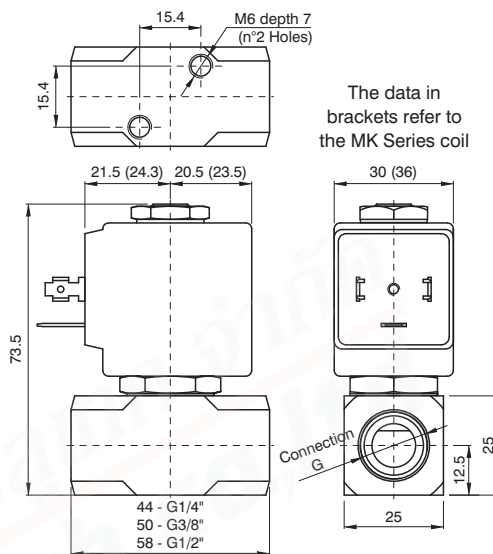

CODE "V"=Seals in FPM ⊕ = Coil	Connection G ISO 228	Orifice (mm)	KV (m³/h)	Differential pressure (bar)			Power Consumption			Coil ⊕		Temp. range (°C)
				Min	Max		AC Inrush	VA Holding	DC Watt	Series	Size	
					AC	DC						
F3110BV25⊕	1/4"	2,5	0,15	0	16	14	20	15	10	MG	30	-10 +140
F3110BV35⊕	1/4"	3,5	0,32	0	10	8	20	15	10	MG	30	
F3110BV45⊕	1/4"	4,5	0,41	0	6,5	3,5	20	15	10	MG	30	
F3110CV35⊕	3/8"	3,5	0,32	0	10	8	20	15	10	MG	30	
F3110CV52⊕	3/8"	5,2	0,47	0	4	1,8	20	15	10	MG	30	
F3110DV35⊕	1/2"	3,5	0,32	0	10	8	20	15	10	MG	30	
F3110DV52⊕	1/2"	5,2	0,47	0	4	1,8	20	15	10	MG	30	
F3110DV64⊕	1/2"	6,4	0,64	0	3,5	1	20	15	10	MG	30	
F3110BV25⊕	1/4"	2,5	0,15	0	35	33	40	30	27	MK	36	
F3110BV35⊕	1/4"	3,5	0,32	0	20	19	40	30	27	MK	36	
F3110BV45⊕	1/4"	4,5	0,41	0	14	13	40	30	27	MK	36	
F3110CV35⊕	3/8"	3,5	0,32	0	20	19	40	30	27	MK	36	
F3110CV52⊕	3/8"	5,2	0,47	0	10	9	40	30	27	MK	36	
F3110DV35⊕	1/2"	3,5	0,32	0	20	19	40	30	27	MK	36	
F3110DV52⊕	1/2"	5,2	0,47	0	10	9	40	30	27	MK	36	
F3110DV64⊕	1/2"	6,4	0,64	0	5	4,5	40	30	27	MK	36	

N.B. For use with steam, maximum admitted pressure PS is 6 bar (relative pressure)
Example: F3110BV25⊕ => F3110BV25MG5:
2-way solenoid normally closed valve, direct plunger operation with Connector G (ISO228) 1/4", Seals in FPM, Orifice 2,5 mm, Coil 24V DC (MG5, size 30).

Pneumatic symbol

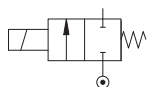

Diagram

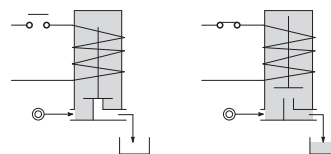

Operational characteristic

- Stainless Steel Body
- Guide pipe in Stainless Steel
- Mobile and fixed core in Stainless Steel
- Springs in Stainless Steel
- Sealing assemblies in FPM

- OPTIONS (if requested):

- Manual operation
- Advance ring in silver
- For use with oxygen

Technical characteristic

Maximum admitted pressure (bar)	100
Maximum fluid viscosity (mm ² /s)	25cSt
Ambient temperature: with class F coil (°C)	-10 +55
Ambient temperature: with class H coil (°C)	-10 +80
Mounting position	indifferent
Weight (gr.) with MG Series Coil	360
Weight (gr.) with MK Series Coil	440

1
AIR DISTRIBUTION

► 2-way solenoid normally closed valve, direct plunger operation

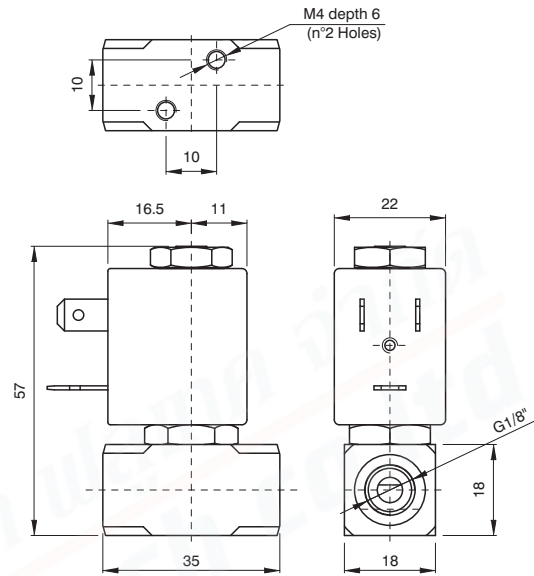

1
AIR DISTRIBUTION

CODE "V" = Seals in FPM "C" = Coil	Connection G ISO 228	Orifice (mm)	KV (m³/h)	Differential pressure (bar)				Power Consumption			Coil C		Temp. range (°C)
				Min	Max		AC Inrush	VA Holding	DC Watt	Series	Size		
					AC	DC							
F3111AV12C	1/8"	1,2	0,04	0	25	25	12	8	6,5	MI	22	-10 +140	
F3111AV15C	1/8"	1,5	0,06	0	16	16	12	8	6,5	MI	22		
F3111AV20C	1/8"	2	0,09	0	12	10	12	8	6,5	MI	22		

N.B. For use with steam, maximum admitted pressure PS is 6 bar (relative pressure)

Example: F3111AV12C => F3111AV12MI56:

2-way solenoid normally closed valve, direct plunger operation with Connector G (ISO228) 1/8", Seals in FPM, Orifice 1,2 mm, Coil 24V 50/60Hz (MI56, size 22).

Pneumatic symbol

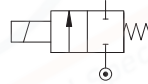

Diagram

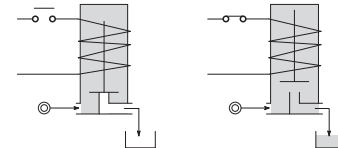

Operational characteristic

- Stainless Steel Body
- Guide pipe in Stainless Steel
- Mobile and fixed core in Stainless Steel
- Springs in Stainless Steel
- Sealing assemblies in FPM

- OPTIONS (if requested):

- Advance ring in silver
- Coil for potentially explosive environments meeting 'ATEX standards Ex m Serie XME'.
- For use with oxygen

Technical characteristic

Maximum admitted pressure (bar)	50
Maximum fluid viscosity (mm ² /s)	25cSt
Ambient temperature: with class F coil (°C)	-10 +55
Ambient temperature: with class H coil (°C)	-10 +80
Mounting position	indifferent
Weight (g.)	150



► 2-way normally closed diaphragm solenoid valve in stainless steel AISI 316, servo-actuated

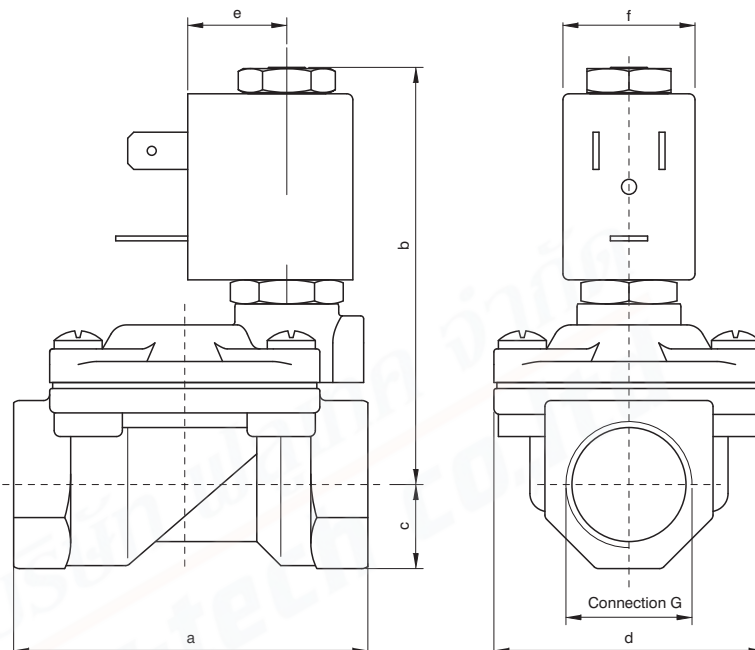

Connection	a	b	c	d	e	f	Weight (g)
G3/8"	59	70	11	45	16	22	300
G1/2"	59	70	13	45	16	22	320
G3/4"	80	75	16	55	16	22	550
G1"	100	84	20	72	16	22	950

CODE "V"=Seals in FPM ⊕ = Coil	Connection G ISO 228	Orifice (mm)	KV (m³/h)	Differential pressure (bar)			Power Consumption			Coil ⊕		Temp. range (°C)
				Min	Max		AC Inrush	VA Holding	DC Watt	Series	Size	
					AC	DC						
F3177CV12⊕	3/8"	12	2,2	0,15	15	15	12	8	6,5	MI	22	-10 +140
F3177DV12⊕	1/2"	12	2,5	0,15	15	15	12	8	6,5	MI	22	
F3177EV18⊕	3/4"	18	5,5	0,15	13	13	12	8	6,5	MI	22	
F3177FV25⊕	1"	24	10,2	0,15	10	10	12	8	6,5	MI	22	

N.B. For use with steam maximum admitted pressure PS is 2.5 bar (relative pressure)
Example: F3177CV12⊕ => F3177CV12MI5:

2-way normally closed diaphragm solenoid valve in stainless steel AISI 316, servo-actuated with Connector G (ISO228) 3/8", Seals in FPM, Orifice 12 mm, Coil 24V DC (MI5, size 22).

Pneumatic symbol

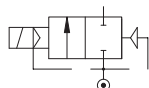

Diagram

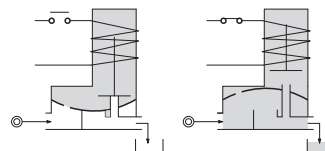

Operational characteristic

- Body and cover in Stainless Steel.
- Guide pipe in Stainless Steel
- Mobile and fixed core in Stainless Steel
- Springs in Stainless Steel
- Sealing assemblies in FPM

- OPTIONS (if requested):

- Manual operation
- Coil for potentially explosive environments meeting 'ATEX standards Ex m Serie XME'.
- Seals for use with foodstuff fluids.
- Version with slowed commutation
- Version for use with oxygen
- Advance ring in silver

Technical characteristic

Minimum differential pressure (bar)	0,15
Maximum admitted pressure (bar)	25
Maximum fluid viscosity (mm ² /s)	25cSt
Ambient temperature: with class F coil (°C)	-10 +55
Ambient temperature: with class H coil (°C)	-10 +80
Mounting position	Preferably with coil upwards

1
AIR DISTRIBUTION

► 2-way normally open with direct operated plunger solenoid valve

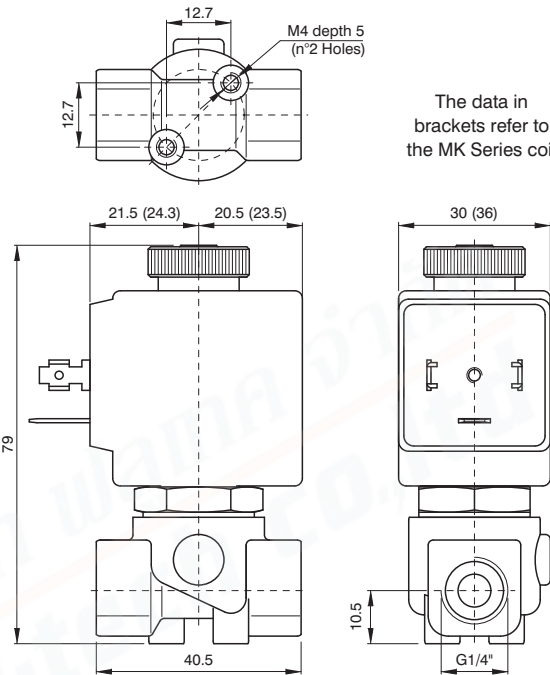

CODE "V"=Seals in FPM ⊕ = Coil	Connection G ISO 228	Orifice (mm)	KV (m³/h)	Differential pressure (bar)				Power Consumption			Coil ⊕		Temp. range (°C)
				Min	Max		AC Inrush	VA Holding	DC Watt	Series	Size		
					AC	DC							
F3206BV15⊕	1/4"	1,5	0,07	0	23	-	20	15	-	MG	30	-10 +140	
F3206BV20⊕	1/4"	2,0	0,1	0	17	-	20	15	-	MG	30		
F3206BV25⊕	1/4"	2,5	0,15	0	12	-	20	15	-	MG	30		
F3206BV35⊕	1/4"	3,5	0,32	0	7	-	20	15	-	MG	30		
F3206BV45⊕	1/4"	4,5	0,41	0	4,5	-	20	15	-	MG	30		
F3206BV52⊕	1/4"	5,2	0,47	0	3	-	20	15	-	MG	30		
F3206BV15⊕	1/4"	1,5	0,07	0	23	23	20	15	-	MK	36		
F3206BV20⊕	1/4"	2,0	0,1	0	17	17	40	30	27	MK	36		
F3206BV25⊕	1/4"	2,5	0,15	0	12	12	40	30	27	MK	36		
F3206BV35⊕	1/4"	3,5	0,32	0	7	7	40	30	27	MK	36		
F3206BV45⊕	1/4"	4,5	0,41	0	4,5	4,5	40	30	27	MK	36		
F3206BV52⊕	1/4"	5,2	0,47	0	3	3	40	30	27	MK	36		
F3206BV64⊕	1/4"	6,4	0,64	0	3,5	3,5	40	30	27	MK	36		

N.B. For use with steam maximum admitted pressure PS is 2.5 bar (relative pressure)

Example: F3206BV15⊕ => F3206BV15MG58:

2-way normally open with direct operated plunger solenoid valve with Connector G (ISO228) 1/4", Seals in FPM, Orifice 1,5 mm, Coil 220V 50/60Hz (MG58, size 30).

Pneumatic symbol

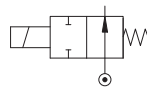

Diagram

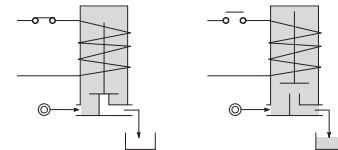

Operational characteristic

- Brass Body.
- Guide pipe in Brass.
- Mobile and fixed core in Stainless Steel
- Springs in Stainless Steel
- Sealing assemblies in FPM

- OPTIONS (if requested):

- Surface treatment in chemical nickel-plating
- Guide pipe in Stainless Steel

Technical characteristic

Maximum admitted pressure (bar)	50
Maximum fluid viscosity (mm ² /s)	25cSt
Ambient temperature: with class F coil (°C)	-10 +55
Ambient temperature: with class H coil (°C)	-10 +80
Mounting position	indifferent
Weight (gr.) with MG Series Coil	300
Weight (gr.) with MK Series Coil	380



► 2-way normally open with direct operated plunger solenoid valve

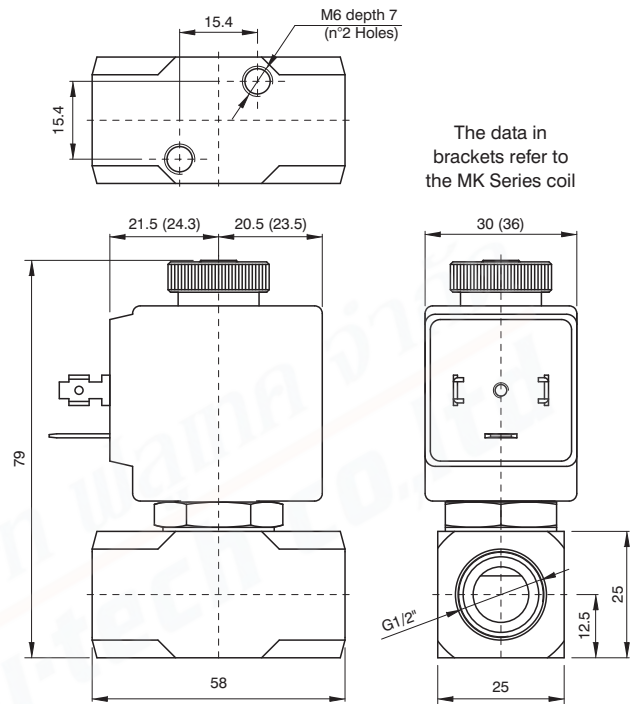

CODE "V" = Seals in FPM ⊕ = Coil	Connection G ISO 228	Orifice (mm)	KV (m ³ /h)	Differential pressure (bar)			Power Consumption			Coil ⊕		Temp. range (°C)
				Min	Max		AC Inrush	VA Holding	DC Watt	Series	Size	
					AC	DC						
F3206DV52⊕	1/2"	5,2	0,47	0	3	-	20	15	-	MG	30	-10 +140
F3206DV52⊕	1/2"	5,2	0,47	0	3	3	40	30	27	MK	36	
F3206DV64⊕	1/2"	6,4	0,64	0	3,5	3,5	40	30	27	MK	36	

N.B. For use with steam maximum admitted pressure PS is 2.5 bar (relative pressure)
Example: F3206DV30⊕ => F3206DV30MG58:
2-way normally open with direct operated plunger solenoid valve with Connector G (ISO228) 1/2", Seals in FPM, Orifice 3 mm, Coil) 220V 50/60Hz (MG58, size 30).

Pneumatic symbol

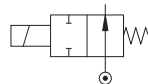

Diagram

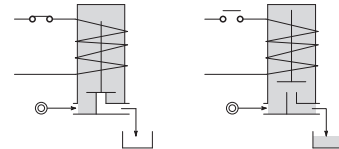

Operational characteristic

- Brass Body.
- Guide pipe in Brass.
- Mobile and fixed core in Stainless Steel
- Springs in Stainless Steel
- Sealing assemblies in FPM
- **OPTIONS (if requested):**
- Surface treatment in chemical nickel-plating
- Guide pipe in Stainless Steel

Technical characteristic

Maximum admitted pressure (bar)	50
Maximum fluid viscosity (mm ² /s)	25cSt
Ambient temperature: with class F coil (°C)	-10 +55
Ambient temperature: with class H coil (°C)	-10 +80
Mounting position	indifferent
Weight (gr.) with MG Series Coil	360
Weight (gr.) with MK Series Coil	440

1
AIR DISTRIBUTION

► 2-way normally open servo-actuated diaphragm solenoid valve

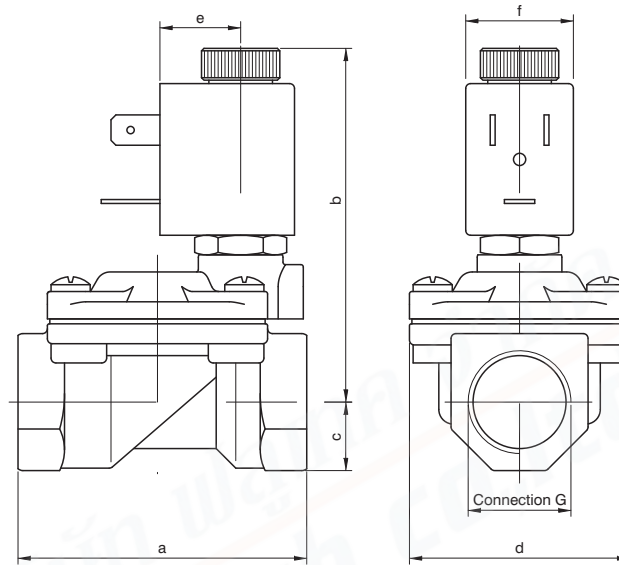

Connection	a	b	c	d	e	f	Weight (g)
G1/4" Ø10	49	69	11	32	16	22	230
G3/8" Ø10	49	69	11	32	16	22	240
G1/2" Ø12	59	74	14	45	16	22	390
G3/4"	79	81	18	55	16	22	650
G1"	96	89	20	72	16	22	1050

CODE "v"=Seals in FPM ⊕ = Coil	Connection G ISO 228	Orifice (mm)	KV (m³/h)	Differential pressure (bar)		Power Consumption			Coil ⊕		Temp. range (°C)	
				Min	Max	AC Inrush	VA Holding	DC Watt	Series	Size		
												AC
F3207BV10⊕	1/4"	10	1,5	0,15	15	15	12	8	6,5	MI	22	-10 +140
F3207CV10⊕	3/8"	10	1,7	0,15	15	15	12	8	6,5	MI	22	
F3207DV12⊕	1/2"	12	2,5	0,15	15	15	12	8	6,5	MI	22	
F3207EV18⊕	3/4"	18	5,5	0,15	13	13	12	8	6,5	MI	22	
F3207FV25⊕	1"	24	10,2	0,15	10	10	12	8	6,5	MI	22	

N.B. For use with steam maximum admitted pressure PS is 2.5 bar (relative pressure)

Example: F3207BV10⊕ => F3207BV10MI5:

2-way normally open servo-actuated diaphragm solenoid valve with Connector G (ISO228) 1/4", Seals in FPM, Orifice 10 mm, Coil 24V DC (MI5, size 22).

Pneumatic symbol	Diagram												
<p>Operational characteristic</p> <ul style="list-style-type: none"> - Body and cover in Brass - Guide pipe in Stainless Steel - Mobile and fixed core in Stainless Steel - Springs in Stainless Steel - Sealing assemblies in FPM <p>- OPTIONS (if requested):</p> <ul style="list-style-type: none"> - Surface treatment in chemical nickel-plating - Coil for potentially explosive environments meeting 'ATEX standards Ex m Serie XME'. 	<p>Technical characteristic</p> <table border="1"> <tr> <td>Minimum differential pressure (bar)</td> <td>0,15</td> </tr> <tr> <td>Maximum admitted pressure (bar)</td> <td>25</td> </tr> <tr> <td>Maximum fluid viscosity (mm²/s)</td> <td>25cSt</td> </tr> <tr> <td>Ambient temperature: with class F coil (°C)</td> <td>-10 +55</td> </tr> <tr> <td>Ambient temperature: with class H coil (°C)</td> <td>-10 +80</td> </tr> <tr> <td>Mounting position</td> <td>indifferent</td> </tr> </table>	Minimum differential pressure (bar)	0,15	Maximum admitted pressure (bar)	25	Maximum fluid viscosity (mm ² /s)	25cSt	Ambient temperature: with class F coil (°C)	-10 +55	Ambient temperature: with class H coil (°C)	-10 +80	Mounting position	indifferent
Minimum differential pressure (bar)	0,15												
Maximum admitted pressure (bar)	25												
Maximum fluid viscosity (mm ² /s)	25cSt												
Ambient temperature: with class F coil (°C)	-10 +55												
Ambient temperature: with class H coil (°C)	-10 +80												
Mounting position	indifferent												

2-way normally open with direct operated plunger solenoid valve

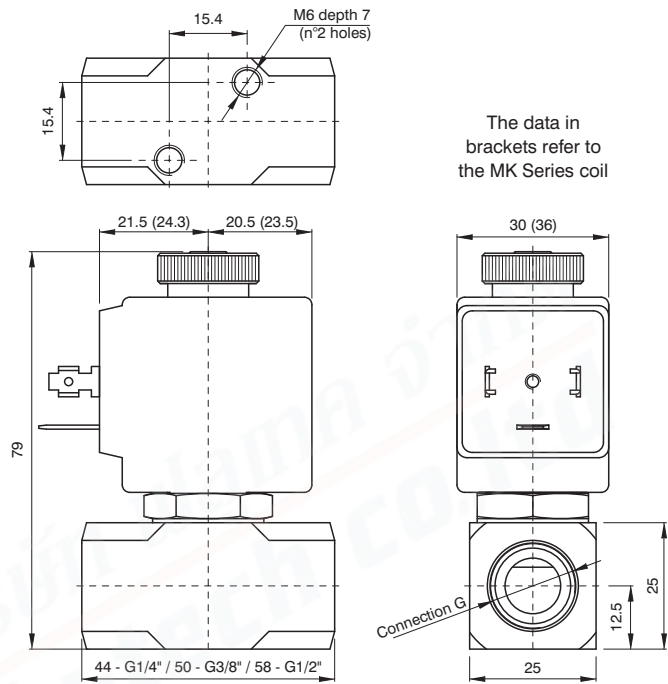

CODE "V"=Seals in FPM ⊕ = Coil	Connection G ISO 228	Orifice (mm)	KV (m³/h)	Differential pressure (bar)			Power Consumption			Coil ⊕		Temp. range (°C)
				Min	Max		AC Inrush	VA Holding	DC Watt	Series	Size	
					AC	DC						
F3210BV25⊕	1/4"	2,5	0,15	0	10	-	20	15	-	MG	30	-10 +140
F3210BV35⊕	1/4"	3,5	0,32	0	7	-	20	15	-	MG	30	
F3210BV45⊕	1/4"	4,5	0,41	0	4,5	-	20	15	-	MG	30	
F3210CV35⊕	3/8"	3,5	0,32	0	7	-	20	15	-	MG	30	
F3210CV52⊕	3/8"	5,2	0,47	0	3	-	20	15	-	MG	30	
F3210DV35⊕	1/2"	3,5	0,32	0	7	-	20	15	-	MG	30	
F3210DV52⊕	1/2"	5,2	0,47	0	3	-	20	15	-	MG	30	
F3210BV25⊕	1/4"	2,5	0,15	0	10	10	40	30	27	MK	36	
F3210BV35⊕	1/4"	3,5	0,32	0	7	7	40	30	27	MK	36	
F3210BV45⊕	1/4"	4,5	0,41	0	4,5	4,5	40	30	27	MK	36	
F3210CV35⊕	3/8"	3,5	0,32	0	7	7	40	30	27	MK	36	
F3210CV52⊕	3/8"	5,2	0,47	0	3	3	40	30	27	MK	36	
F3210DV35⊕	1/2"	3,5	0,32	0	7	7	40	30	27	MK	36	
F3210DV52⊕	1/2"	5,2	0,47	0	3	3	40	30	27	MK	36	
F3210DV64⊕	1/2"	6,4	0,64	0	3,5	3,5	40	30	27	MK	36	

N.B. For use with steam maximum admitted pressure PS is 2.5 bar (relative pressure)
Example: F3210BV25⊕ => F3210BV25MG56:
2-way normally open with direct operated plunger solenoid valve with Connector G (ISO228) 1/4", Seals in FPM, Orifice 2,5 mm, Coil 24V 50/60Hz (MG56, size 30).

Pneumatic symbol

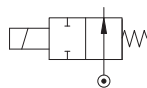

Diagram

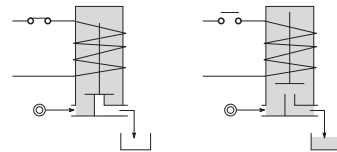

Operational characteristic

- Stainless Steel Body
- Guide pipe in Stainless Steel
- Mobile and fixed core in Stainless Steel
- Springs in Stainless Steel
- Sealing assemblies in FPM

- OPTIONS (if requested):
- Advance ring in silver

Technical characteristic

Maximum admitted pressure (bar)	50
Maximum fluid viscosity (mm ² /s) 25cSt	25cSt
Ambient temperature: with class F coil (°C) -10 +55	-10 +55
Ambient temperature: with class H coil (°C) -10 +80	-10 +80
Mounting position	indifferent

► 2-way normally open with direct operated plunger solenoid valve

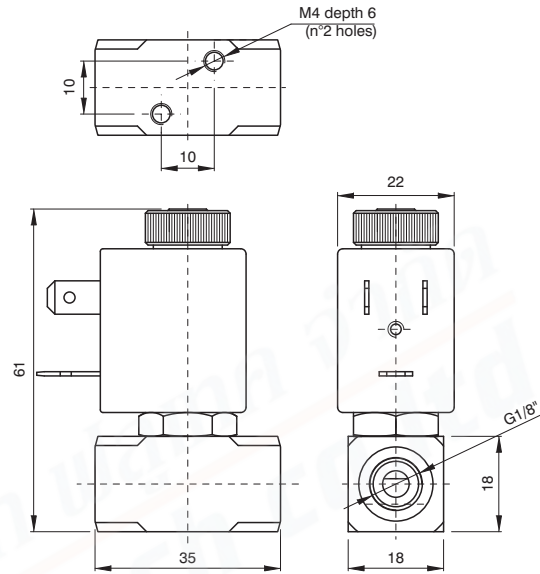

CODE "v"=Seals in FPM ⊕ = Coil	Connection G ISO 228	Orifice (mm)	KV (m ³ /h)	Differential pressure (bar)				Power Consumption			Coil ⊕		Temp. range (°C)
				Min	Max		AC Inrush	VA Holding	DC Watt	Series	Size		
					AC	DC							
F3211AV12⊕	1/8"	1,2	0,04	0	19	19	12	8	6,5	MI	22	-10 +140	
F3211AV15⊕	1/8"	1,5	0,06	0	14	14	12	8	6,5	MI	22		
F3211AV20⊕	1/8"	2	0,09	0	8	8	12	8	6,5	MI	22		

N.B. For use with steam maximum admitted pressure PS is 2.5 bar (relative pressure)
Example: F3211AV12⊕ => F3211AV12MI56:

2-way normally open with direct operated plunger solenoid valve with Connector G (ISO228) 1/8", Seals in FPM, Orifice 1,2 mm, Coil 24V 50/60Hz (MI56, size 22).

Pneumatic symbol

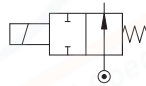

Diagram

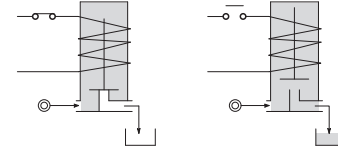

Operational characteristic

- Stainless Steel Body
- Guide pipe in Stainless Steel
- Mobile and fixed core in Stainless Steel
- Springs in Stainless Steel
- Sealing elements in FPM

- OPTIONS (if requested):

- Coil for potentially explosive environments meeting 'ATEX standards Ex m Serie XME'.

Technical characteristic

Maximum admitted pressure (bar)	50
Maximum fluid viscosity (mm ² /s)	25cSt
Ambient temperature: with class F coil (°C)	-10 +55
Ambient temperature: with class H coil (°C)	-10 +80
Mounting position	indifferent



▶ 2-way normally open servo-actuated diaphragm solenoid valve in stainless steel AISI 316

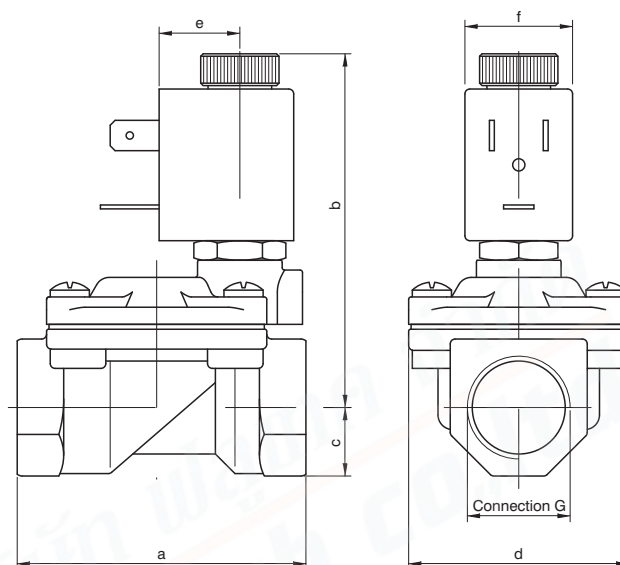

Connection	a	b	c	d	e	f	Weight (g)
G3/8"	59	74	11	45	16	22	300
G1/2"	59	74	13	45	16	22	320
G3/4"	80	78	16	55	16	22	550
G1"	100	88	20	72	16	22	1350

CODE "V" = Seals in FPM "C" = Coil	Connection G ISO 228	Orifice (mm)	KV (m³/h)	Differential pressure (bar)			Power Consumption			Coil "C"		Temp. range (°C)
				Min	Max		AC Inrush	VA Holding	DC Watt	Series	Size	
					AC	DC						
F3277CV12C	3/8"	12	2,2	0,15	15	15	12	8	6,5	MI	22	-10 +140
F3277DV12C	1/2"	12	2,5	0,15	15	15	12	8	6,5	MI	22	
F3277EV18C	3/4"	18	5,5	0,15	13	13	12	8	6,5	MI	22	
F3277FV25C	1"	24	10,2	0,15	10	10	12	8	6,5	MI	22	

N.B. For use with steam maximum admitted pressure PS is 2.5 bar (relative pressure)
Example: F3277CV12C => F3277CV12MI5:

2-way normally open servo-actuated diaphragm solenoid valve in stainless steel AISI 316 with Connector G (ISO228) 3/8", Seals in FPM, Orifice 12 mm, Coil 24V DC (MI5, size 22).

Pneumatic symbol

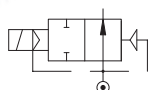

Diagram

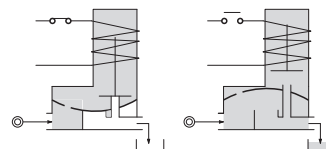

Operational characteristic

- Body and cover in Stainless Steel.
- Guide pipe in Stainless Steel
- Mobile and fixed core in Stainless Steel
- Springs in Stainless Steel
- Sealing assemblies in FPM

- OPTIONS (if requested):

- Coil for potentially explosive environments meeting 'ATEX standards Ex m Serie XME'.
- Seals for use with foodstuff fluids.
- Advance ring in silver

Technical characteristic

Minimum differential pressure (bar)	0,15
Maximum admitted pressure (bar)	25
Maximum fluid viscosity (mm ² /s)	25cSt
Ambient temperature: with class F coil (°C)	-10 +55
Ambient temperature: with class H coil (°C)	-10 +80
Mounting position	Preferably with coil upwards

1
AIR DISTRIBUTION



3-way direct acting solenoid valve

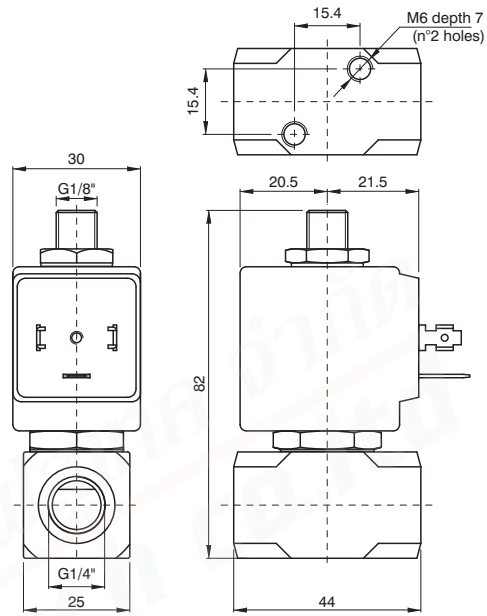

CODE "V"=Seals in FPM ⊕ = Coil	Connection G ISO 228	Orifice (mm)		KV (m³/h)	Differential pressure (bar)			Power Consumption			Coil ⊕		Temp. range (°C)
		alim.	scar.		Min	Max		AC Inrush	VA Holding	DC Watt	Series	Size	
						AC	DC						
U Universal													
F3310BV25U⊕	1/4"	2,5	2,4	0,16	0	5	4	20	15	10	MG	30	-10 +140

Example: F3310BV25G⊕ => F3310BV25GMG5:
3-way direct acting solenoid valve with Connector G (ISO228) 1/4", Seals in FPM, Feed bore 2,5 mm, Exhaust bore 2,4 mm Coil 24V DC (MG5, size 30), N.O.

Pneumatic symbol

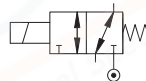

Diagram

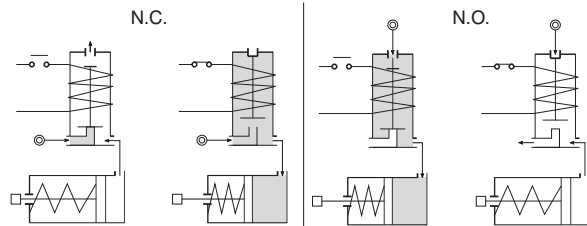

Operational characteristic

- Stainless Steel body
- Guide pipe in Stainless Steel
- Mobile and fixed core in Stainless Steel
- Springs in Stainless Steel
- Sealing assemblies in FPM
- **OPTIONS (if requested):**
- Advance ring in silver

Technical characteristic

Maximum admitted pressure (bar)	Maximum running pressure + 10%
Maximum fluid viscosity (mm ² /s)	25cSt
Ambient temperature: with class F coil (°C)	-10 +55
Ambient temperature: with class H coil (°C)	-10 +80
Mounting position	indifferent
Weight (g.)	150



3-way direct acting solenoid valve

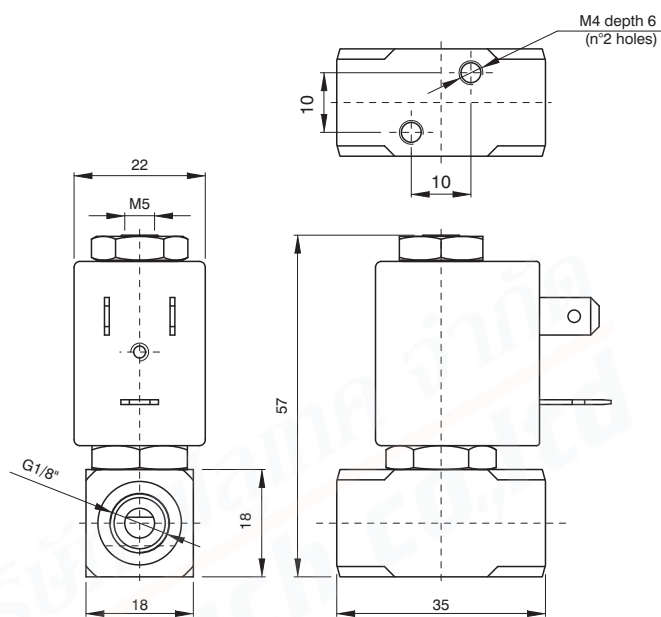

CODE "V"=Seals in FPM ⊕ = Bobna	Connection G ISO 228	Orifice (mm)		KV (m³/h)	Differential pressure (bar)			Power Consumption			Coil ⊕		Temp. range (°C)	
		alim.	scar.		Min	Max		AC	VA	DC	Series	Size		
						AC	DC	Spunto	Regime	Watt				
U Universal														
F3311AV15U⊕	1/8"	1,5	1,5	0,06	0	6	6	12	8	6,5	MI	22	-10 +140	

Example: F3311AV15G⊕ => F3311AV15GM15:
3-way direct acting solenoid valve with Connector G (ISO228) 1/8", Seals in FPM, Feed bore 1,5 mm, Exhaust bore 1,5 mm Coil 24V DC (MI5, size 22), N.O.

Pneumatic symbol

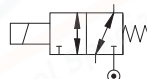

Diagram

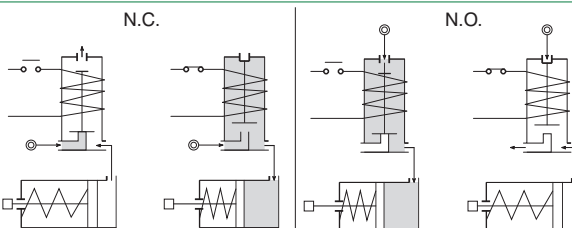

Operational characteristic

- Stainless Steel Body
- Guide pipe in Stainless Steel
- Mobile and fixed core in Stainless Steel
- Springs in Stainless Steel
- Sealing assemblies in FPM

- OPTIONS (if requested):

- Advance ring in silver
- Coil for potentially explosive environments meeting 'ATEX standards Ex m Serie XME'.
- Exhaust with hose mount.

Technical characteristic

Maximum admitted pressure (bar)	Maximum running pressure + 10%
Maximum fluid viscosity (mm ² /s)	25cSt
Ambient temperature: with class F coil (°C)	-10 +55
Ambient temperature: with class H coil (°C)	-10 +80
Mounting position	indifferent
Weight (g.)	150

▶ 2-way normally closed servo-actuated towed membrane solenoid valve

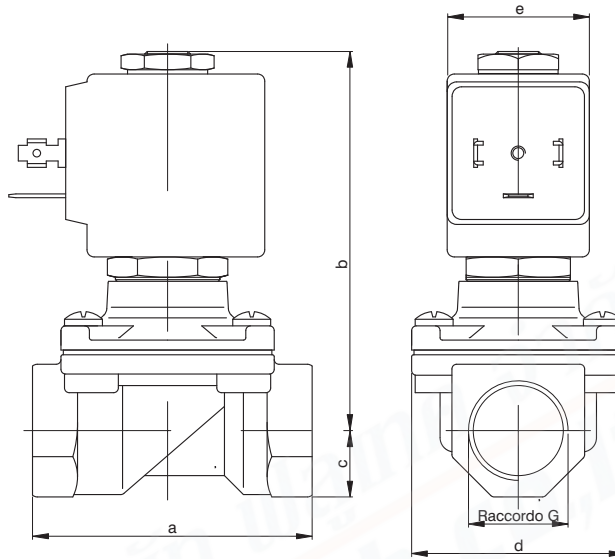

1
AIR DISTRIBUTION

Connection	a	b	c	d	e	f	Weight (g) Series 2	Weight (g) Series 5
G3/8" Ø12	59	83	14	45	16	36	0,50	0,58
G1/2"	59	83	14	45	16	36	0,45	0,53
G3/4"	79	90	18	55		36	-	0,75
G1"	96	101	20	72		36	-	1,10

CODE "V"=Seals in FPM "E" = Coil	Connection G ISO 228	Orifice (mm)	KV (m³/h)	Differential pressure (bar)			Power Consumption			Coil Ⓜ		Temp. range (°C)
				Min	Max		AC Inrush	VA Holding	DC Watt	Series	Size	
					AC	DC						
F3108CV12Ⓜ	3/8"	12	2	0	10	-	20	15	-	MG	30	-10 +140
F3108DV12Ⓜ	1/2"	12	2.2	0	10	-	20	15	-	MG	30	
F3108CV12Ⓜ	3/8"	12	2	0	12	10	40	30	27	MK	36	
F3108DV12Ⓜ	1/2"	12	2.2	0	12	10	40	30	27	MK	36	
F3108EV18Ⓜ	3/4"	18	4.5	0	9	-	40	30	-	MK	36	
F3108FV25Ⓜ	1"	24	8.5	0	7	-	40	30	-	MK	36	
F3108EV18CⓂ	3/4"	18	4.5	0	-	9	-	-	27	MK	36	
F3108FV25CⓂ	1"	24	8.5	0	-	8	-	-	27	MK	36	

Example: F3108DV12Ⓜ => F3108DV12MG5:

2-way normally closed in brass with towed membrane solenoid valve with Connector G (ISO228) 1/2", Seals in FPM, Orifice 12 mm, Coil 24V DC (MG5, size 30).

Pneumatic symbol

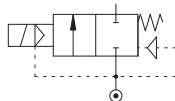

Diagram

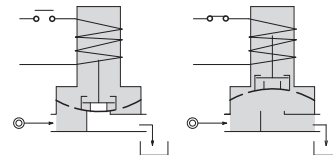

Operational characteristic

- Body and cover in Brass
- Guide pipe in Stainless Steel
- Mobile and fixed core in Stainless Steel
- Springs in Stainless Steel
- Sealing assemblies in FPM
- **OPTIONS (if requested):**
- Surface treatment in chemical nickel-plating

Technical characteristic

Maximum admitted pressure (bar)	25
Maximum fluid viscosity (mm²/s)	25cSt
Ambient temperature: with class F coil (°C)	-10 +55
Ambient temperature: with class H coil (°C)	-10 +80
Mounting position	Preferably with coil upwards

2-way normally closed servo-actuated piston solenoid valve 1/4"

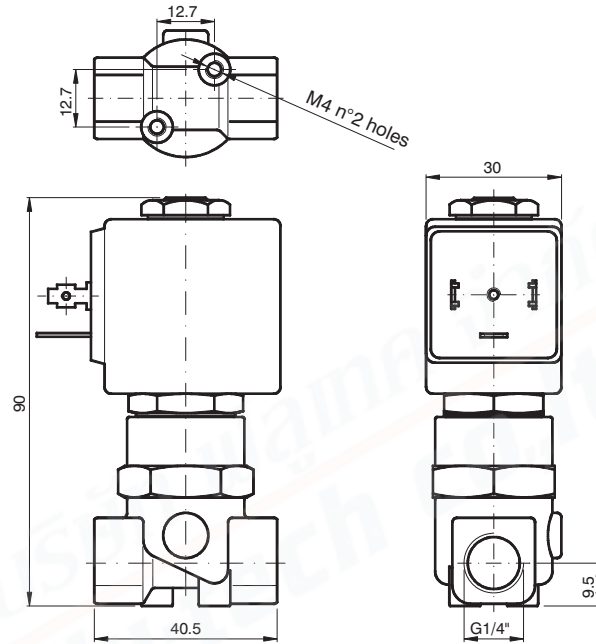

1
AIR DISTRIBUTION

CODE "V"=Seals in FPM ⊕ = Coil	Connection G ISO 228	Orifice (mm)	KV (m ³ /h)	Differential pressure (bar)			Power Consumption			Coil ⊕		Temp. range (°C)
				Min	Max		AC Inrush	VA Holding	DC Watt	Series	Size	
					AC	DC						
F3119BV52⊕	1/4"	5,2	0,47	1,5	50	50	20	15	10	MG	30	-10 +140

Example: F3119BV52⊕ => F3119BV52MG5:
2-way normally closed servo-actuated piston solenoid valve in brass with Connector G (ISO228) 1/4", Seals in FPM, Orifice 5,2 mm, Coil 24V DC (MG5, size 30).

Pneumatic symbol

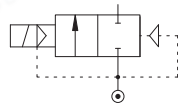

Diagram

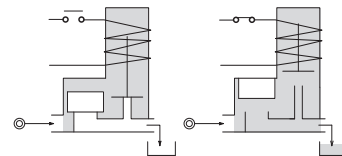

Operational characteristic

- Body and cover in Brass
- Guide pipe in Stainless Steel
- Mobile and fixed core in Stainless Steel
- Springs in Stainless Steel
- Piston in Brass.
- Guide slide in loaded PTFE.
- Main shutter in PTFE.
- Remaining sealing elements in FPM.
- **OPTIONS (if requested):**
- Surface treatment in chemical nickel-plating

Technical characteristic

Minimum differential pressure (bar)	1
Maximum admitted pressure (bar)	40
Maximum running pressure Versione /1 (bar)	60
Maximum fluid viscosity (mm ² /s)	25cSt
Ambient temperature: with class F coil (°C)	-10 +55
Ambient temperature: with class H coil (°C)	-10 +80
Mounting position	630
Weight (g.)	Preferably with coil upwards

▶ 2-way normally closed, servo-actuated piston solenoid valve

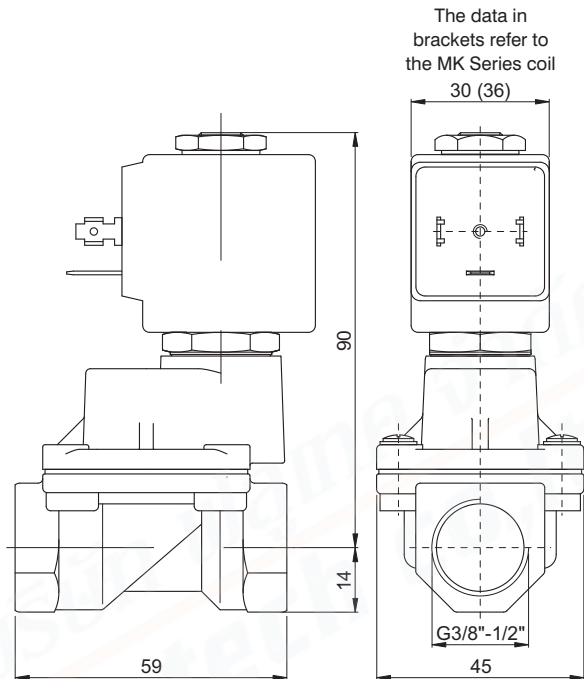

The data in brackets refer to the MK Series coil 30 (36)

CODE "V"=Seals in FPM ⊕ = Coil	Connection G ISO 228	Orifice (mm)	KV (m ³ /h)	Differential pressure (bar)				Power Consumption			Coil ⊕		Temp. range (°C)
				Min	Max		AC Inrush	VA Holding	DC Watt	Series	Size		
					AC	DC							
F3119CV12⊕	3/8"	12	2	1	30	30	20	15	10	MG	30	-10 +140	
F3119DV12⊕	1/2"	12	2.2	1	30	30	20	15	10	MG	30		
F3119CV12/1⊕	3/8"	12	2	1	50	50	40	30	27	MK	36		
F3119DV12/1⊕	1/2"	12	2.2	1	50	50	40	30	27	MK	36		

Example: F3119DV12⊕ => F3108DV12MG5:

2-way normally closed servo-actuated piston solenoid valve in brass with Connector G (ISO228) 1/2", Seals in FPM, Orifice 12 mm, Coil 24V DC (MG5, size 30).

Pneumatic symbol

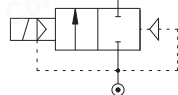

Diagram

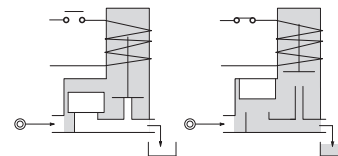

Operational characteristic

- Body and cover in Brass
- Guide pipe in Stainless Steel
- Mobile and fixed core in Stainless Steel
- Springs in Stainless Steel
- Piston in Brass.
- Guide slide in loaded PTFE.
- Main shutter in PTFE.
- Remaining sealing elements in FPM.

- **OPTIONS (if requested):**
- Surface treatment in chemical nickel-plating

Technical characteristic

Minimum differential pressure (bar)	1
Maximum admitted pressure (bar)	40
Maximum running pressure Versione /1 (bar)	60
Maximum fluid viscosity (mm ² /s)	25cSt
Ambient temperature: with class F coil (°C)	-10 +55
Ambient temperature: with class H coil (°C)	-10 +80
Mounting position	Preferably with coil upwards
Weight (gr.) with MG Series Coil	630
Weight (gr.) with MK Series Coil	710

▶ 2-way normally closed servo-actuated piston solenoid valve for use with steam

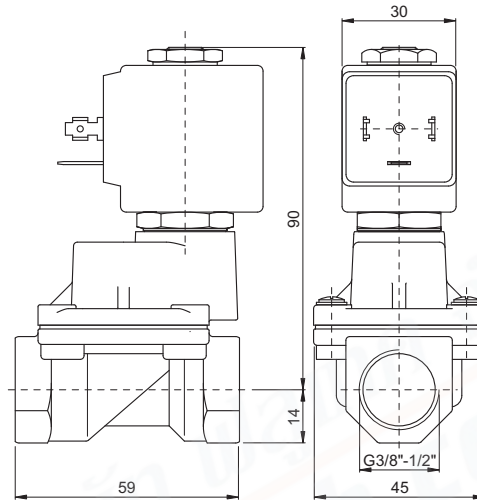

1
AIR DISTRIBUTION

CODE "V"=Seals in FPM ⊕ = Coil	Connection G ISO 228	Orifice (mm)	KV (m³/h)	Differential pressure (bar)			Power Consumption			Coil ⊕		Temp. range (°C)
				Min	Max		AC Inrush	VA Holding	DC Watt	Series	Size	
					AC	DC						
F3119CW12/1⊕	3/8"	12	2	2,5	9	9	20	15	10	MG	30	-10 +180
F3119DW12/1⊕	1/2"	12	2.2	2,5	9	9	20	15	10	MG	30	-10 +180

Example: F3119DW12/1⊕ => F3119DW12/1MG5:
2-way normally closed servo-actuated piston solenoid valve in brass with Connector G (ISO228) 1/2", Seals in FPM, Orifice 12 mm, Coil 24V DC (MG5, size 30).

Pneumatic symbol		Diagram									
Operational characteristic - Body and cover in Brass - Guide pipe in Stainless Steel - Mobile and fixed core in Stainless Steel - Springs in Stainless Steel - Piston in Stainless Steel. - Guide slide in loaded PTFE. - Sealing elements in PTFE/FPM. - OPTIONS (if requested): - Surface treatment in chemical nickel-plating - Steam sealing up to +160°C		Technical characteristic <table border="1"> <tr> <td>Minimum differential pressure (bar)</td> <td>2,5</td> </tr> <tr> <td>Ambient temperature: only with class H Coil (°C)</td> <td>-10 +80</td> </tr> <tr> <td>Mounting position</td> <td>Preferably with coil upwards</td> </tr> <tr> <td>Weight (g.)</td> <td>630</td> </tr> </table>		Minimum differential pressure (bar)	2,5	Ambient temperature: only with class H Coil (°C)	-10 +80	Mounting position	Preferably with coil upwards	Weight (g.)	630
Minimum differential pressure (bar)	2,5										
Ambient temperature: only with class H Coil (°C)	-10 +80										
Mounting position	Preferably with coil upwards										
Weight (g.)	630										

2-way solenoid normally closed valve, direct plunger operation, with housing for potentially explosive environments certified: CESI 03 ATEX 344 ExII2G/D Eex "d" IIC T6

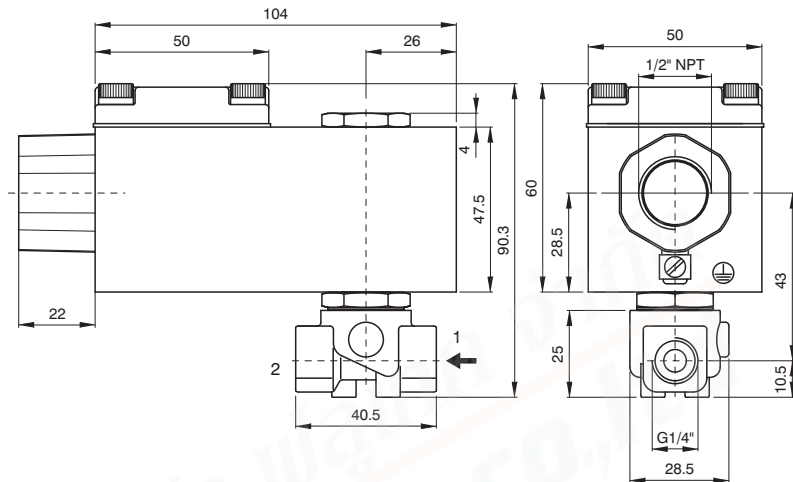

CODE "V"=Seals in FPM "C" = Coil	Connection G ISO 228	Orifice (mm)	KV (m³/h)	Differential pressure (bar)			Power Consumption		Temp. range (°C)	Coil Ⓢ Series A6 (CURRENT)
				Min	Max		AC Inrush	DC Watt		
					AC	DC				
FX3106BV35C	1/4"	3,5	0,32	0	10	8	12	8	-10 +140	A6B=24 Volt (AC 50/60Hz)
FX3106BV45C	1/4"	4,5	0,41	0	6,5	3,5	12	8		A6E=220/230 Volt (AC 50/60Hz)
										A60=12 Volt (DC)
										A61=24 Volt (DC)

N.B. The solenoid valve is suited for intercepting only fluids that are NOT potentially explosive.

Example: FX3106BV35b => FX3106BV35A60:

2-way solenoid normally closed valve, direct plunger operation, with housing for potentially explosive environments certified:
CESI 03 ATEX 344 ExII2G/D Eex "d" IIC T6 with Connector G (ISO228) 1/4", Seals in FPM, Orifice 3,5 mm, Coil 12V DC (A60).

Pneumatic symbol

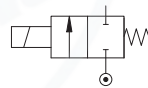

Diagram

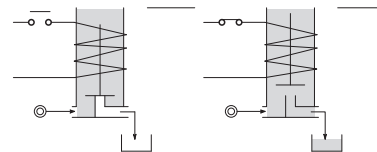

Operational characteristic

- Brass Body
- Container in light red coloured alloy
- Electrical connection 1/2" NPT
- Sealing elements in FPM
- **OPTIONS (if requested):**
 - Manual operation
 - Surface treatment in chemical nickel-plating
 - Inserted stainless steel seating

Technical characteristic

Maximum admitted pressure (bar)	80
Maximum fluid viscosity (mm ² /s)	25cSt
Ambient temperature (°C)	-10 +40
Mounting position	With coil upwards
Weight (g.)	600



2-way normally closed direct acting solenoid valve with housing for potentially explosive environments certified: CESI 03 ATEX 344 ExII2G/D Eex "d" IIC T6

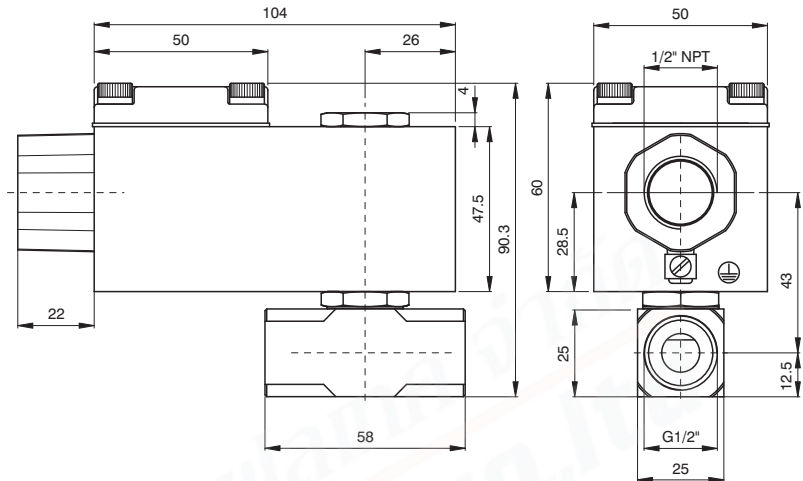

CODE "v"=Seals in FPM ⊕ = Coil	Connection G ISO 228	Orifice (mm)	KV (m ³ /h)	Differential pressure (bar)			Power Consumption		Temp. range (°C)	Coil ⊕ Series A6 (CURRENT)
				Min	Max		AC Inrush	DC Watt		A6B=24 Volt (AC 50/60Hz) A6E=220/230 Volt (AC 50/60Hz) A60=12 Volt (DC) A61=24 Volt (DC)
					AC	DC				
FX3106DV52⊕	1/2"	5,2	0,47	0	4	1,8	12	8	-10 +140	
FX3106DV64⊕	1/2"	6,4	0,64	0	3	1	12	8	-10 +140	

N.B. The solenoid valve is suited for intercepting only fluids that are NOT potentially explosive.
Example: FX3106DV52⊕ => FX3106DV52A60:
2-way solenoid normally closed valve, direct plunger operation, with housing for potentially explosive environments certified: CESI 03 ATEX 344 ExII2G/D Eex "d" IIC T6, with Connector G (ISO228) 1/2", Seals in FPM, Orifice 5,2 mm, Coil 12V DC (A60).

Pneumatic symbol

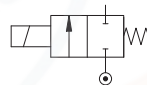

Diagram

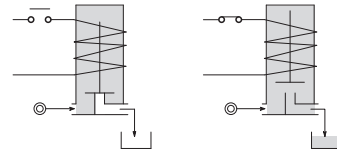

Operational characteristic

- Brass Body
- Container in light red coloured alloy
- Electrical connection 1/2" NPT
- Sealing elements in FPM
- OPTIONS (if requested):
 - Manual operation
 - Surface treatment in chemical nickel-plating
 - Inserted stainless steel seating

Technical characteristic

Maximum admitted pressure (bar)	80
Maximum fluid viscosity (mm ² /s)	25cSt
Ambient temperature (°C)	-10 +40
Mounting position	With coil upwards
Weight (g.)	660

2-Way normally closed solenoid valve, servo-actuated diaphragm, with housing for potentially explosive environments certified: CESI 03 ATEX 344 ExII2G/ D Eex "d" IIC T6

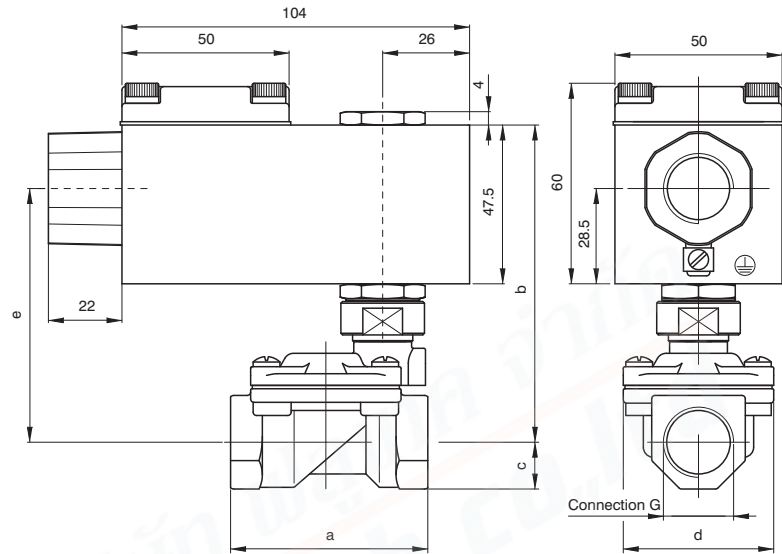

Connection G	a	b	c	d	e	Weight (g)
G1/4" Ø10	49	90	11	32	71	720
G3/8" Ø12	59	95	14	45	76	920
G1/2" Ø12	59	95	14	45	76	920
G3/4"	79	101	18	54	82	1100
G1"	96	110	20	72	91	1500

CODE "V"=Seals in FPM ⊕ = Coil	Connection G ISO 228	Orifice (mm)	KV (m³/h)	Differential pressure (bar)			Power Consumption		Temp. range (°C)
				Min	Max		AC Inrush	DC Watt	
					AC	DC			
FX3107BV10⊕	1/4"	10	1,5	0,15	15	15	12	8	-10 +140
FX3107CV12⊕	3/8"	12	2,2	0,15	15	15	12	8	
FX3107DV12⊕	1/2"	12	2,5	0,15	15	15	12	8	
FX3107EV18⊕	3/4"	18	5,5	0,15	13	13	12	8	
FX3107FV25⊕	1"	24	10,2	0,15	10	10	12	8	

Coil ⊕ Series A6
CURRENT
A6B=24 Volt (AC 50/60Hz)
A6E=220/230 Volt (AC 50/60Hz)
A60=12 Volt (DC)
A61=24 Volt (DC)

N.B. The solenoid valve is suited for intercepting only fluids that are NOT potentially explosive.

Example: FX3107BV101⊕ => FX3107BV101A60:

2-Way normally closed solenoid valve, servo-actuated diaphragm, with housing for potentially explosive environments certified: CESI 03 ATEX 344 ExII2G/D Eex "d" IIC T6, with Connector G (ISO228) 1/4", Seals in FPM, Orifice 10 mm, Coil 12V DC (A60).

Pneumatic symbol

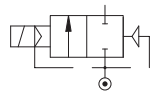

Diagram

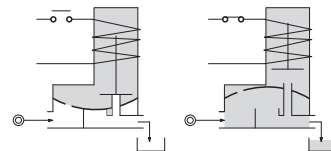

Operational characteristic

- Body and cover in Brass
- Container in light red coloured alloy
- Electrical connection 1/2" NPT
- Sealing elements in FPM
- **OPTIONS (if requested):**
 - Surface treatment in chemical nickel-plating
 - Version with slowed commutation

Technical characteristic

Minimum differential pressure (bar)	0,15
Maximum admitted pressure (bar)	25
Maximum fluid viscosity (mm ² /s)	25cSt
Ambient temperature (°C)	-10 +40
Mounting position	Preferably with coil upwards

► **2-Way normally closed direct acting solenoid valve with housing for potentially explosive environments certified: CESI 03 ATEX 344 ExII2G/D Eex "d" IIC T6**

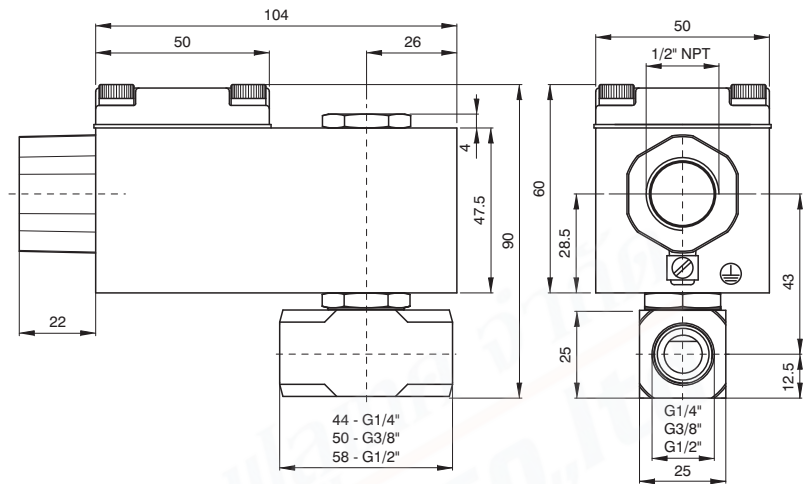

CODE "V"=Seals in FPM ⊕ = Coil	Connection G ISO 228	Orifice (mm)	KV (m³/h)	Differential pressure (bar)			Power Consumption		Temp. range (°C)	Coil ⊕ Series A6 CURRENT
				Min	Max		AC Inrush	DC Watt		
					AC	DC				
FX3110BV25⊕	1/4"	2,5	0,15	0	16	14	12	8	-10 +140	A6B=24 Volt (AC 50/60Hz) A6E=220/230 Volt (AC 50/60Hz) A60=12 Volt (DC) A61=24 Volt (DC)
FX3110BV35⊕	1/4"	3,5	0,32	0	10	8	12	8		
FX3110BV45⊕	1/4"	4,5	0,41	0	6,5	3,5	12	8		
FX3110CV35⊕	3/8"	3,5	0,32	0	10	8	12	8		
FX3110CV52⊕	3/8"	5,2	0,47	0	4	1,8	12	8		
FX3110DV35⊕	1/2"	3,5	0,32	0	10	8	12	8		
FX3110DV52⊕	1/2"	5,2	0,47	0	4	1,8	12	8		
FX3110DV64⊕	1/2"	6,4	0,64	0	3,5	1	12	8		

N.B. The solenoid valve is suited for intercepting only fluids that are NOT potentially explosive.

Example: FX3110BV25⊕ => FX3110BV25A60:

2-Way normally closed direct acting solenoid valve with housing for potentially explosive environments certified:

CESI 03 ATEX 344 ExII2G/D Eex "d" IIC T6, with Connector G (ISO228) 1/4", Seals in FPM, Orifice 2,5 mm, Coil 12V DC (A60).

Pneumatic symbol

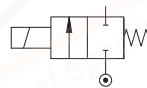

Diagram

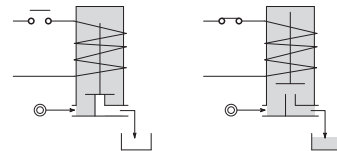

Operational characteristic

- Stainless Steel Body
- Container in light red coloured alloy
- Electrical connection 1/2" NPT
- Sealing elements in FPM

- OPTIONS (if requested):**
- Advance ring in silver

Technical characteristic

Maximum admitted pressure (bar)	100
Maximum fluid viscosity (mm ² /s)	25cSt
Ambient temperature (°C)	-10 +40
Mounting position	with coil upwards
Weight (g.)	660

1
AIR DISTRIBUTION

2-Way normally closed servo-actuated diaphragm solenoid valve in stainless steel AISI 316, with housing for potentially explosive environments certified: CESI 03 ATEX 344 ExII2G/D Eex "d" IIC T6

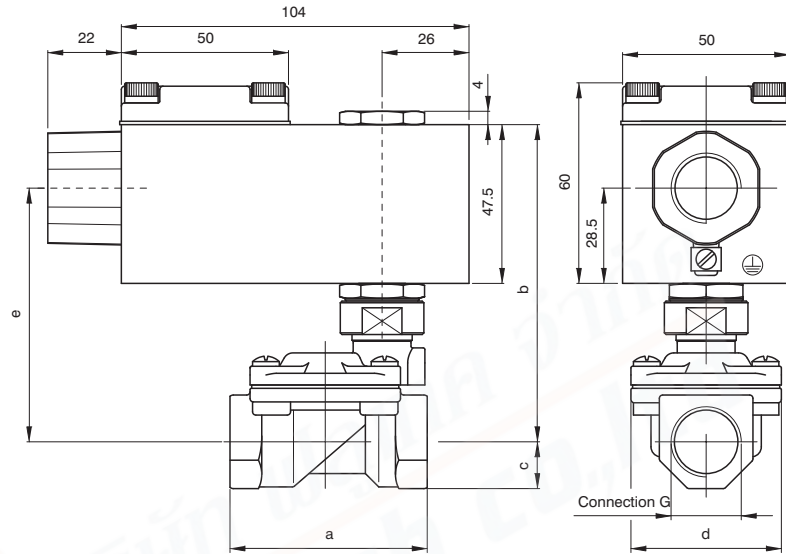

Connection G	a	b	c	d	e	Weight (g)
G3/8"	59	95	14	45	76	1120
G1/2"	59	95	14	45	76	1110
G3/4"	79	101	18	54	82	1100
G1"	96	110	20	72	91	1500

CODE	Connection G ISO 228	Orifice (mm)	KV (m³/h)	Differential pressure (bar)			Power Consumption		Temp. range (°C)
				Min	Max		AC Inrush	DC Watt	
					AC	DC			
FX3177CV121Ⓢ	3/8"	12	2,2	0,15	15	15	12	8	-10 +140
FX3177DV121Ⓢ	1/2"	12	2,5	0,15	15	15	12	8	
FX3177EV181Ⓢ	3/4"	18	5,5	0,15	13	13	12	8	
FX3177FV251Ⓢ	1"	24	10,2	0,15	10	10	12	8	

Coil Ⓢ Series A6
CURRENT
A6B=24 Volt (AC 50/60Hz)
A6E=220/230 Volt (AC 50/60Hz)
A6O=12 Volt (DC)
A6I=24 Volt (DC)

N.B. The solenoid valve is suited for intercepting only fluids that are NOT potentially explosive.

Example: FX3177CV121Ⓢ => FX3177CV121A60:

2-Way normally closed servo-actuated diaphragm solenoid valve in stainless steel AISI 316, with housing for potentially explosive environments certified: CESI 03 ATEX 344 ExII2G/D Eex "d" IIC T6, with Connector G (ISO228) 3/8", Seals in FPM, Orifice 12 mm, Coil 12V DC (A60).

Pneumatic symbol

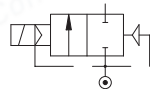

Diagram

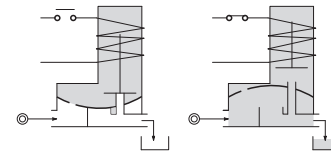

Operational characteristic

- Body and cover in Stainless Steel
- Container in light red coloured alloy
- Electrical connection 1/2" NPT
- Sealing elements in FPM

- OPTIONS (if requested):**
- Version with slowed commutation

Technical characteristic

Minimum differential pressure (bar)	0,15
Maximum admitted pressure (bar)	25
Maximum fluid viscosity (mm²/s)	25cSt
Ambient temperature (°C)	-10 +40
Mounting position	Preferably with coil upwards

► **MG Series coil (Size 30 mm), class F**

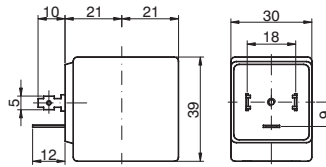

Ordering code	
MGT	
VOLTAGE	
56=24 Volt (AC 50/60Hz)	
T	58=220/230 Volt (AC 50/60Hz)
5=24 Volt (DC)	
4=12 Volt (DC)	

Options:
Electrical connection via cables
Special voltages and powers.

Operational characteristic							
Class of insulation	Tolerance on AC voltage	Tolerance on DC voltage	Degree of protection with connector fitted	Continuous service	Electrical conn.	Connectors	Weight (g.)
F	+15% -10%	± 10%	IP65	ED100%	DIN 43650A	PG9 Codice 10349000	120

► **MI Series coil (Size 22 mm), class F**

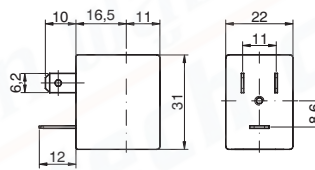

Ordering code	
MI	
VOLTAGE	
56=24 Volt (AC 50/60Hz)	
T	58=220/230 Volt (AC 50/60Hz)
5=24 Volt (DC)	
4=12 Volt (DC)	
21=48-50 Volt (AC 50/60Hz)	

Options:
Electrical connection via cables
Special voltages and powers.

Operational characteristic							
Class of insulation	Tolerance on AC voltage	Tolerance on DC voltage	Degree of protection with connector fitted	Continuous service	Electrical conn.	Connectors	Weight (g.)
F	+15% -10%	± 10%	IP65	ED100%	DIN 43650A	PG9 Codice 10349000	120

► **MK Series coil (Size 36 mm), class H**

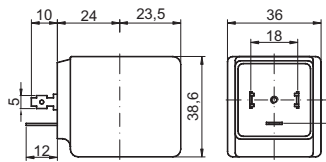

Ordering code	
MKT	
VOLTAGE	
56=24 Volt (AC 50/60Hz)	
T	58=220/230 Volt (AC 50/60Hz)
5=24 Volt (DC)	
4 =12 Volt (DC)	

Options:
Electrical connection via cables
Special voltages and powers.

Operational characteristic							
Class of insulation	Tolerance on AC voltage	Tolerance on DC voltage	Degree of protection with connector fitted	Continuous service	Electrical conn.	Connectors	Weight (g.)
F	+15% -10%	± 10%	IP00	ED100%	DIN 43650A	PG9 Codice 10349000	200

► **Coils 2G Ex mb IIC T4-T6; II2D Ex mb IIIC T85°C-T135°C (Size 30 mm), Class H**

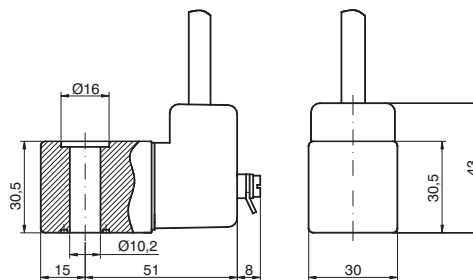

Ordering code	
XME	
VOLTAGE	
56=24 Volt (AC 50/60Hz)	
T	58=220/230 Volt (AC 50/60Hz)
5=24 Volt (DC)	
4 =12 Volt (DC)	

Options:
Electrical connection via cables
Special voltages and powers.

Operational characteristic						
Class of insulation	Tolerance on AC voltage	Tolerance on DC voltage	Degree of protection with connector fitted	Continuous service	Electrical conn.	Weight (g.)
F	+15% -10%	± 10%	IP00	ED100%	3m cable	250