



## Series 888

### General

Competitively priced, good performance and versatility combined with a compact design are the main characteristics of this new series of valves.

The aluminium valve body and spool/seal arrangement optimize both the flow rate and the valve switching time.

This series of valves are available with G1/8" and G1/4" ports in 3/2, 5/2 and 5/3 versions.

Monostable or bistable versions are available and include an integrated technopolymer solenoid operator with 9mm stem and built in manual override.

**Solenoid valves series 888 are available in point-to-point and serial configurations.**

**For serial system specifications, see Optyma-F series.**

The valves can be supplied with or without the solenoid coil, however, if the solenoid coil is required please refer to the following table:

	Voltages	Coil Code	Voltage Code
Direct current DC	12V (3,5W)	MF4	F04
	24V (3,5W)	MF5	F05
Alternating current AC 50 - 60 Hz	24V (3,7W)	MF56	F56
	110V (3,7W)	MF57	F57
	230V (3,7W)	MF58	F58

Connectors Coding		
Voltages		Kit 100 pieces
DC/AC	24V	888.11.01L-K
Alternating current AC 50 - 60 Hz	110V	888.11.02L-K
	230V	888.11.03L-K

### Construction characteristics

Body	Aluminium
Operators	Technopolymer Aluminium for spring bottom plates
Seals	NBR
Spools	Aluminium
Springs	Spring steel
Pistons	Technopolymer

### Use and maintenance

These valves have an average life of 15 million cycles

depending on the application and air quality, filtered and lubricated air using specified lubricants will dramatically reduce the wear of the seals and ensures long and trouble free operation.

Please ensure that the valve is being used according with the manufacturers specification, such as air pressure and temperature.

The exhaust ports 3 and 5 must be protected against the possible ingress of dirt or debris.

Repair kits including the spool complete with seals are available for overhauling the valves; however, although this is a simple operation it should be carried out by a competent person.

1  
AIR DISTRIBUTION



AIR DISTRIBUTION 1

**Solenoid - Spring - 3/2 (Self-feeding)**

**Coding: 8880.32.ⓕ.39.Ⓥ**

Operational characteristics	
Fluid	Filtered air. No lubrication needed, if applied it shall be continuous
Max working pressure (bar)	8
Temperature °C	-5 ÷ +50
Flow rate at 6 bar with Δp=1 (NI/min)	790
Orifice size (mm)	5.8
Working ports size	G 1/8"

FUNCTION	
ⓕ	A = Normally Open
	C = Normally Closed

VOLTAGE	
F04	= 12 VDC
F05	= 24 VDC
Ⓥ F56	= 24 V (50-60 Hz)
F57	= 110 V (50-60 Hz)
F58	= 230 V (50-60 Hz)
F00	= Without coil

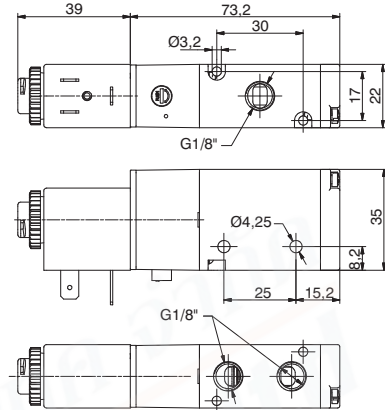
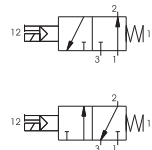

Weight 210 g  
Minimum working pressure 2 bar

**Solenoid - Spring - 5/2 (Self-feeding)**

**Coding: 8880.52.00.39.Ⓥ**

Operational characteristics	
Fluid	Filtered air. No lubrication needed, if applied it shall be continuous
Max working pressure (bar)	8
Temperature °C	-5 ÷ +50
Flow rate at 6 bar with Δp=1 (NI/min)	790
Orifice size (mm)	5.8
Working ports size	G 1/8"

VOLTAGE	
F04	= 12 VDC
F05	= 24 VDC
Ⓥ F56	= 24 V (50-60 Hz)
F57	= 110 V (50-60 Hz)
F58	= 230 V (50-60 Hz)
F00	= Without coil

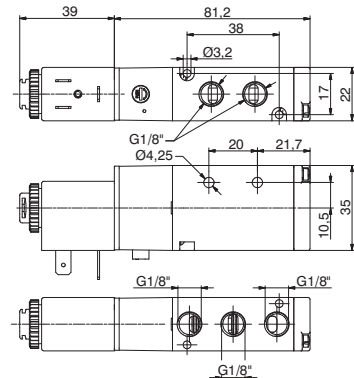
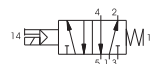

Weight 220 g  
Minimum working pressure 2 bar

**Solenoid - Solenoid - 3/2**

**Coding: 8880.32.00.35.Ⓥ**

Operational characteristics	
Fluid	Filtered air. No lubrication needed, if applied it shall be continuous
Max working pressure (bar)	8
Temperature °C	-5 ÷ +50
Flow rate at 6 bar with Δp=1 (NI/min)	790
Orifice size (mm)	5.8
Working ports size	G 1/8"

VOLTAGE	
F04	= 12 VDC
F05	= 24 VDC
Ⓥ F56	= 24 V (50-60 Hz)
F57	= 110 V (50-60 Hz)
F58	= 230 V (50-60 Hz)
F00	= Without coil

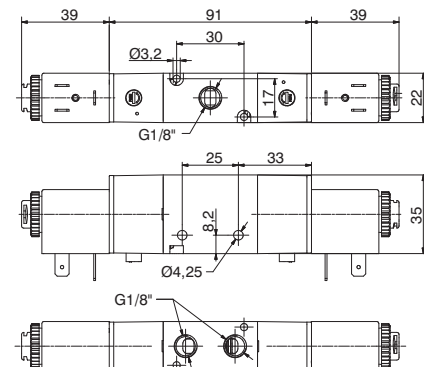

Weight 310 g  
Minimum working pressure 2 bar

**Solenoid - Solenoid - 5 ways 2 connections**

Coding: 8880.52.00.35. **V**

Operational characteristics	
Fluid	Filtered air. No lubrication needed, if applied it shall be continuous
Max working pressure (bar)	8
Temperature °C	-5 ÷ +50
Flow rate at 6 bar with Δp=1 (NI/min)	790
Orifice size (mm)	5.8
Working ports size	G 1/8"

VOLTAGE	
F04	= 12 VDC
F05	= 24 VDC
<b>F56</b>	= 24 V (50-60 Hz)
F57	= 110 V (50-60 Hz)
F58	= 230 V (50-60 Hz)
F00	= Without coil



Weight 320 g  
Minimum working pressure 2 bar

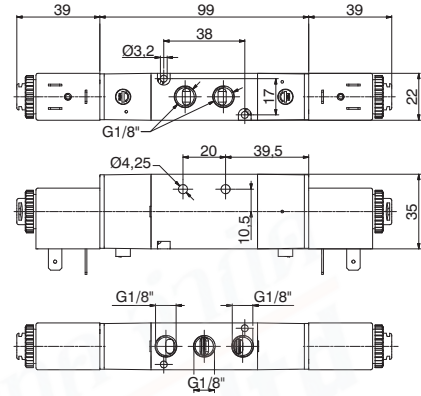

**Solenoid - Solenoid - 5 ways 3 connections**

Coding: 8880.53. **F**.35. **V**

Operational characteristics	
Fluid	Filtered air. No lubrication needed, if applied it shall be continuous
Max working pressure (bar)	8
Temperature °C	-5 ÷ +50
Flow rate at 6 bar with Δp=1 (NI/min)	440
Orifice size (mm)	5.8
Working ports size	G 1/8"

FUNCTION		VOLTAGE	
<b>F</b>	31 = Closed centres	F04	= 12 VDC
	32 = Open centres	F05	= 24 VDC
	33 = Pressured centres	<b>F56</b>	= 24 V (50-60 Hz)
		F57	= 110 V (50-60 Hz)
		F58	= 230 V (50-60 Hz)
		F00	= Without coil

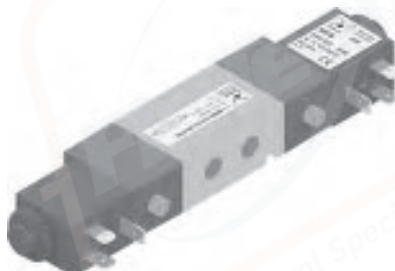

Weight 330 g  
Minimum working pressure 2.5 bar

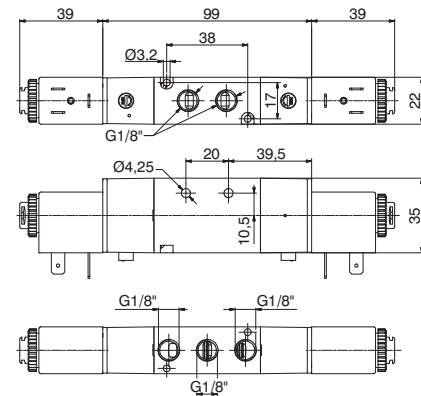
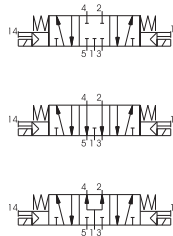

**Solenoid - Spring - 3/2 (External-feeding)**

Coding: 8880E.32. **F**.39. **V**

Operational characteristics	
Fluid	Filtered air. No lubrication needed, if applied it shall be continuous
Max working pressure (bar)	8
Temperature °C	-5 ÷ +50
Flow rate at 6 bar with Δp=1 (NI/min)	790
Orifice size (mm)	5.8
Working ports size	G 1/8"

FUNCTION		VOLTAGE	
<b>F</b>	A = 3/2 Normally Open	F04	= 12 VDC
	C = 3/2 Normally Closed	F05	= 24 VDC
		<b>F56</b>	= 24 V (50-60 Hz)
		F57	= 110 V (50-60 Hz)
		F58	= 230 V (50-60 Hz)
		F00	= Without coil



Weight 210 g  
Minimum working pressure 2 bar

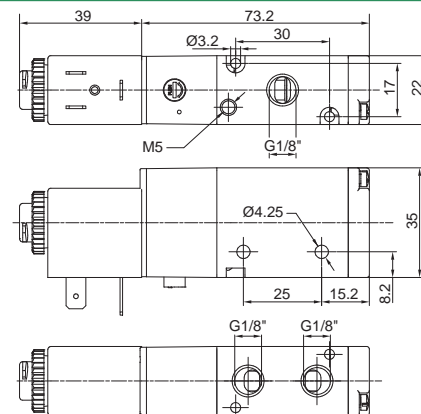
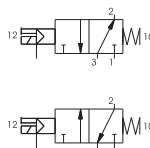

**Solenoid - Spring - 5/2 (External-feeding)**

Coding: 8880E.52.00.39.

Operational characteristics	
Fluid	Filtered air. No lubrication needed, if applied it shall be continuous
Max working pressure (bar)	8
Temperature °C	-5 ÷ +50
Flow rate at 6 bar with Δp=1 (NI/min)	790
Orifice size (mm)	5.8
Working ports size	G 1/8"

VOLTAGE	
F04	= 12 VDC
F05	= 24 VDC
F56	= 24 V (50-60 Hz)
F57	= 110 V (50-60 Hz)
F58	= 230 V (50-60 Hz)
F00	= Without coil



Weight 220 g  
Minimum working pressure 2 bar

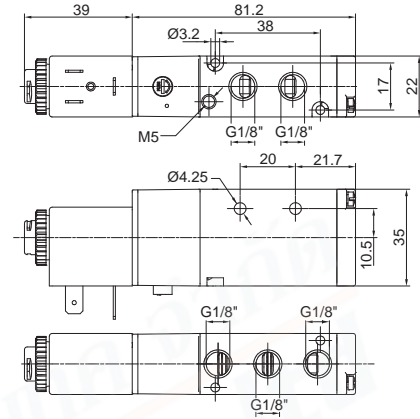
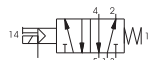

**Solenoid - Solenoid - 3/2 (External-feeding)**

Coding: 8880E.32.00.35.

Operational characteristics	
Fluid	Filtered air. No lubrication needed, if applied it shall be continuous
Max working pressure (bar)	8
Temperature °C	-5 ÷ +50
Flow rate at 6 bar with Δp=1 (NI/min)	790
Orifice size (mm)	5.8
Working ports size	G 1/8"

VOLTAGE	
F04	= 12 VDC
F05	= 24 VDC
F56	= 24 V (50-60 Hz)
F57	= 110 V (50-60 Hz)
F58	= 230 V (50-60 Hz)
F00	= Without coil

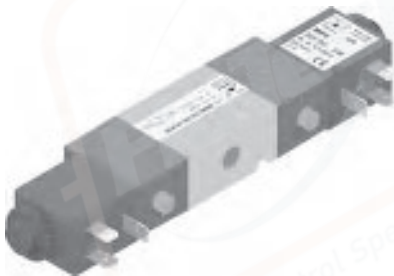

Weight 310 g  
Minimum working pressure 2 bar

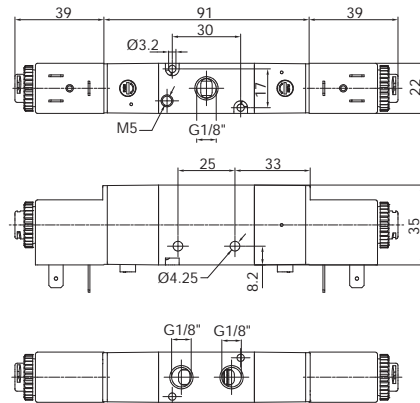
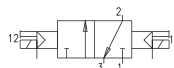

**Solenoid - Solenoid - 5/2 (External-feeding)**

Coding: 8880E.52.00.35.

Operational characteristics	
Fluid	Filtered air. No lubrication needed, if applied it shall be continuous
Max working pressure (bar)	8
Temperature °C	-5 ÷ +50
Flow rate at 6 bar with Δp=1 (NI/min)	790
Orifice size (mm)	5.8
Working ports size	G 1/8"

VOLTAGE	
F04	= 12 VDC
F05	= 24 VDC
F56	= 24 V (50-60 Hz)
F57	= 110 V (50-60 Hz)
F58	= 230 V (50-60 Hz)
F00	= Without coil

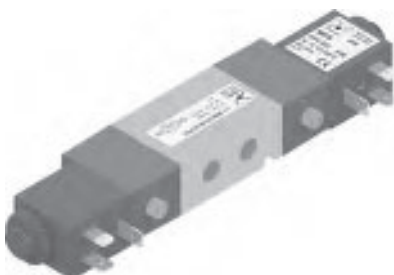

Weight 320 g  
Minimum working pressure 2 bar

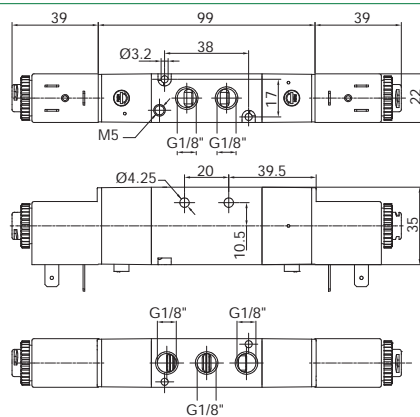

**Solenoid - Solenoid - 5/3 connections (External-feeding)**

Operational characteristics	
Fluid	Filtered air. No lubrication needed, if applied it shall be continuous
Max working pressure (bar)	8
Temperature °C	-5 ÷ +50
Flow rate at 6 bar with Δp=1 (NI/min)	440
Orifice size (mm)	5.8
Working ports size	G 1/8"

Coding: 8880E.53.ⓕ.35.Ⓥ

FUNCTION		VOLTAGE	
ⓕ	31 = Closed centres	Ⓥ	F04 = 12 VDC
	32 = Open centres		F05 = 24 VDC
	33 = Pressured centres		F56 = 24 V (50-60 Hz)
			F57 = 110 V (50-60 Hz)
			F58 = 230 V (50-60 Hz)
			F00 = Without coil

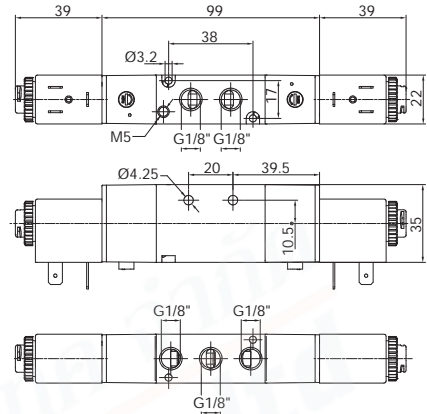
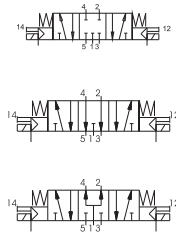

Weight 330 g  
Minimum working pressure 2,5 bar

**Solenoid - Spring - 3/2 (Self-feeding)**

Operational characteristics	
Fluid	Filtered air. No lubrication needed, if applied it shall be continuous
Max working pressure (bar)	8
Temperature °C	-5 ÷ +50
Flow rate at 6 bar with Δp=1 (NI/min)	890
Orifice size (mm)	6.5
Working ports size	G 1/4"

Coding: 8884.32.ⓕ.39.Ⓥ

FUNCTION		VOLTAGE	
ⓕ	A = 3/2 Normally Open	Ⓥ	F04 = 12 VDC
	C = 3/2 Normally Closed		F05 = 24 VDC
			F56 = 24 V (50-60 Hz)
			F57 = 110 V (50-60 Hz)
			F58 = 230 V (50-60 Hz)
			F00 = Without coil

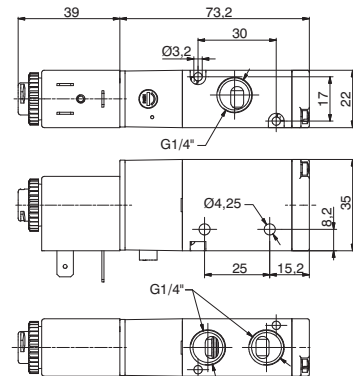
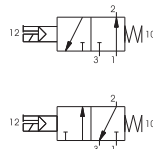

Weight 210 g  
Minimum working pressure 2 bar

**Solenoid - Spring - 5/2 (Self-feeding)**

Operational characteristics	
Fluid	Filtered air. No lubrication needed, if applied it shall be continuous
Max working pressure (bar)	8
Temperature °C	-5 ÷ +50
Flow rate at 6 bar with Δp=1 (NI/min)	890
Orifice size (mm)	6.5
Working ports size	G 1/4"

Coding: 8884.52.00.39.Ⓥ

VOLTAGE	
Ⓥ	F04 = 12 VDC
	F05 = 24 VDC
	F56 = 24 V (50-60 Hz)
	F57 = 110 V (50-60 Hz)
	F58 = 230 V (50-60 Hz)
	F00 = Without coil

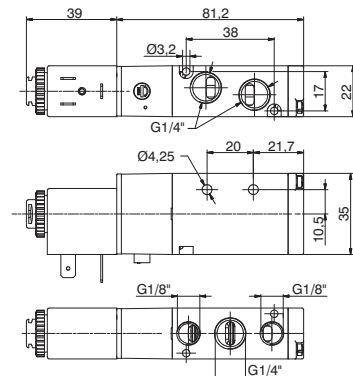

Weight 220 g  
Minimum working pressure 2 bar

1  
AIR DISTRIBUTION



Manifold (Valves 5/2 - 5/3)

Coding: 888.P



CONNECTION TYPE	
02	= nr. 2 positions (270 g)
03	= nr. 3 positions (335 g)
04	= nr. 4 positions (400 g)
05	= nr. 5 positions (465 g)
<b>P</b> 06	= nr. 6 positions (530 g)
07	= nr. 7 positions (595 g)
08	= nr. 8 positions (660 g)
09	= nr. 9 positions (725 g)
10	= nr. 10 positions (790 g)
12	= nr. 12 positions (920 g)
16	= nr. 16 positions (1180 g)

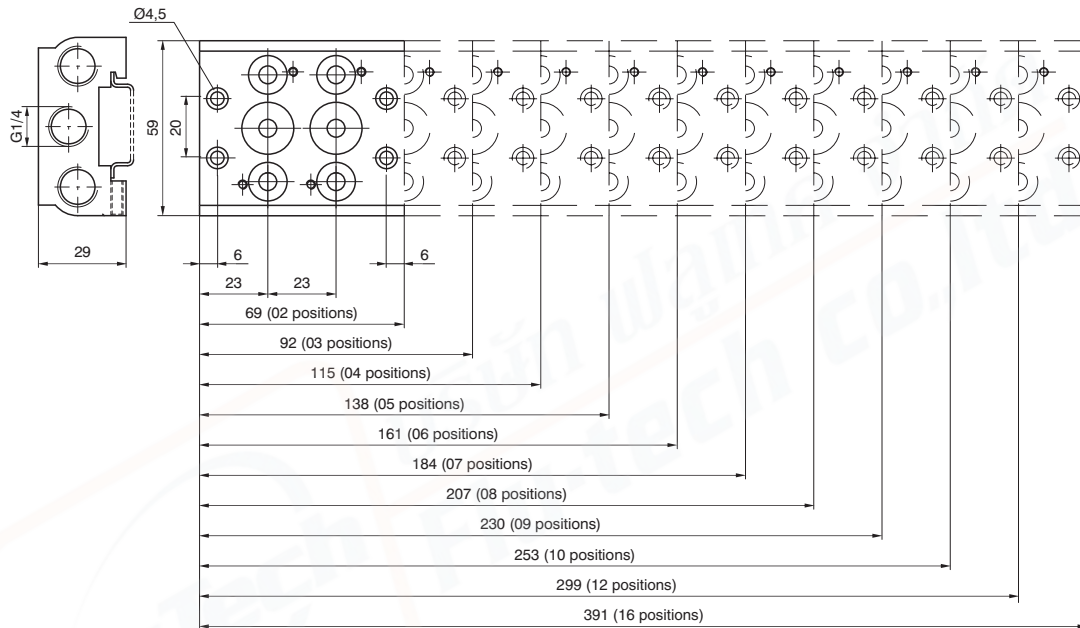

weight 5 g  
(for mounting the distributors groups on guide DIN 46277/3)

Closing plate

Coding: 888.00

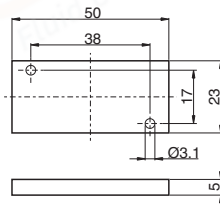

Weight 18 g  
Closing plate supplied complete with 2 fixing screws to the manifold and 2 fixing screws to the multi-polar base



Manifold (Valves 3/2)

Coding: 8883.0



CONNECTION TYPE	
02	= nr. 2 positions (270 g)
03	= nr. 3 positions (335 g)
04	= nr. 4 positions (400 g)
05	= nr. 5 positions (465 g)
06	= nr. 6 positions (530 g)
07	= nr. 7 positions (595 g)
08	= nr. 8 positions (660 g)
09	= nr. 9 positions (725 g)
10	= nr. 10 positions (790 g)
12	= nr. 12 positions (920 g)
16	= nr. 16 positions (1180 g)

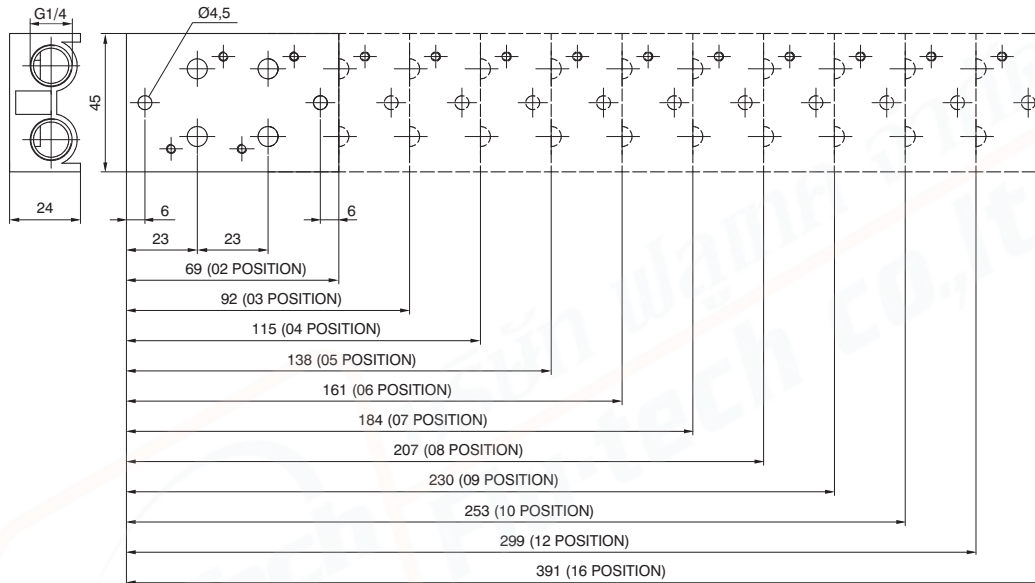

weight 5 g  
(for mounting the distributors groups on guide DIN 46277/3)

Closing plate

Coding: 8883.00

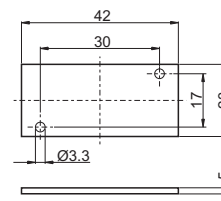

Weight 10 g  
Closing plate supplied complete with 2 fixing screws to the manifold

AIR DISTRIBUTION

1

► Endplate, 37 Poles IP65

Coding: 888M.37.10



Weight 186 g  
The IP65 protection is obtained by IP65 Pneumax cable.  
Code complete with assembled endplate and 4 manifold fixing screws, previously mounted on the Manifold.

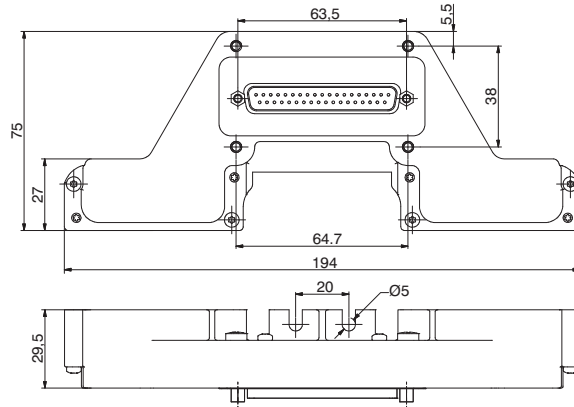

► Endplate, 25 Poles IP65

Coding: 888M.25.10



Weight 181 g  
The IP65 protection is obtained by IP65 Pneumax cable.  
Code complete with assembled endplate and 4 manifold fixing screws, previously mounted on the Manifold.

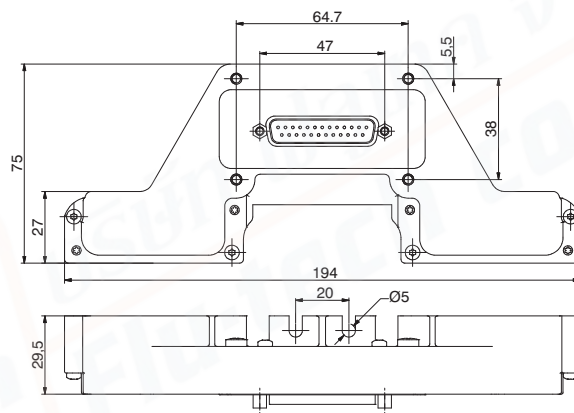

► Modular base, 2 positions IP65

Coding: 888M.02.BM



Weight 220 g  
Complete with seals and fixing screws  
Usable only for 5/2 and 5/3 Distributors

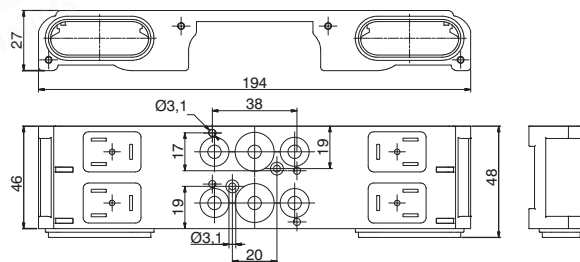

► Left and Right Power board PNP 24 VDC

Coding: 888M.Ⓟ.Ⓡ



weight 5 g  
(for mounting the distributors groups on guide DIN 46277/3)

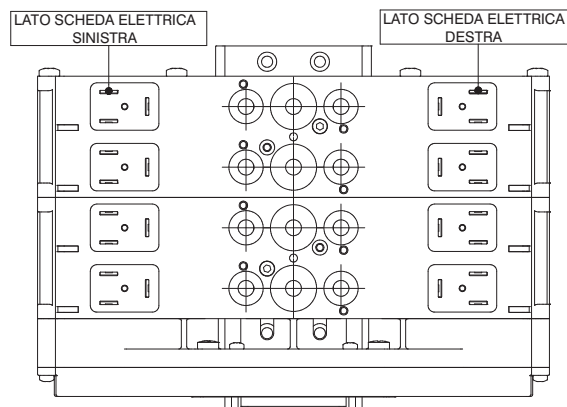

POSITIONS	
04	= nr. 4 positions (11,2 g)
08	= nr. 8 positions (22,4 g)
12	= nr. 12 positions (33,6 g)
16	= nr. 16 positions (44,8 g)
TYPE	
00	= Left
01	= Right

1  
AIR DISTRIBUTION



1  
AIR DISTRIBUTION

► Closing plate

Coding: 888M.22.PC

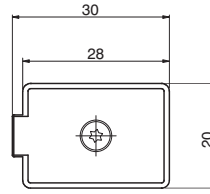

Weight 3 g  
Closing plate supplied complete with 1 Seal and fixing screw with O ring  
Maximum fixing torque for fittings: 0,35Nm

► Multipolar base plug

Coding: 888M.T

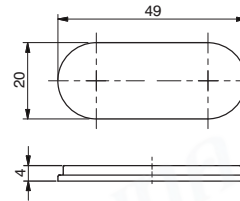

Weight 2,6 g  
Complete with: Nr. 1 Plug, Nr. 2 Fixing screws

► Seals

Coding: 888M.22.G

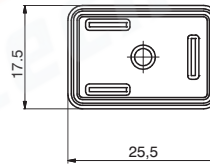

Weight 0,52 g

► In line cable complete with connector IP40

Coding: 2400.Ⓡ.Ⓛ.00



Ⓡ	CONNECTORS
	25 = 25 poles
	37 = 37 poles
Ⓛ	CABLE LENGTH
	03 = 3 meters
	05 = 5 meters
	10 = 10 meters

► Cable complete with connector, 25 Poles IP65

Coding: 2300.25.Ⓛ.Ⓒ



Ⓛ	CABLE LENGTH
	03 = 3 meters
	05 = 5 meters
	10 = 10 meters
Ⓒ	CONNECTOR
	10 = In line
	90 = 90° Angle

► Cable complete with connector, 37 Poles IP65

Coding: 2400.37.Ⓛ.Ⓒ



Ⓛ	CABLE LENGTH
	03 = 3 meters
	05 = 5 meters
	10 = 10 meters
Ⓒ	CONNECTOR
	10 = In line
	90 = 90° Angle



**Manifold layout Configuration Point to Point**

3/2 valves

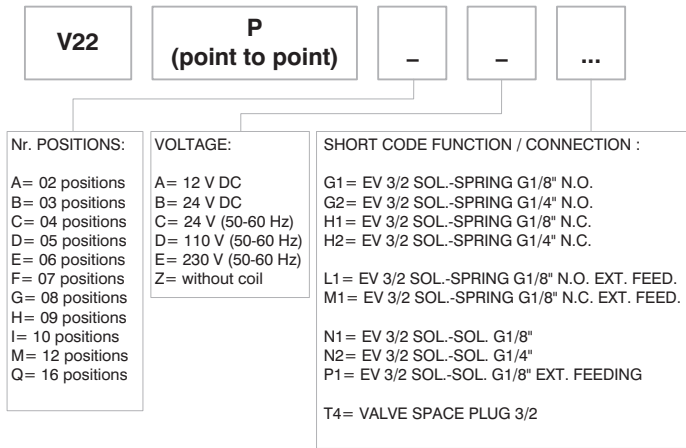

5/2 valves

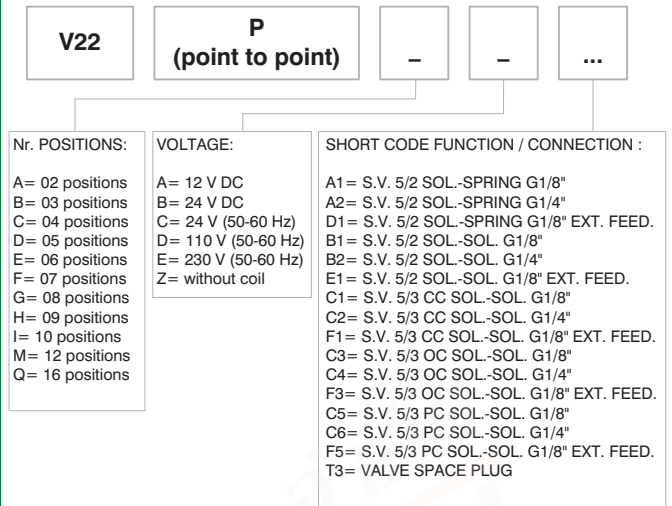

**Manifold layout Configuration Multi-pole**

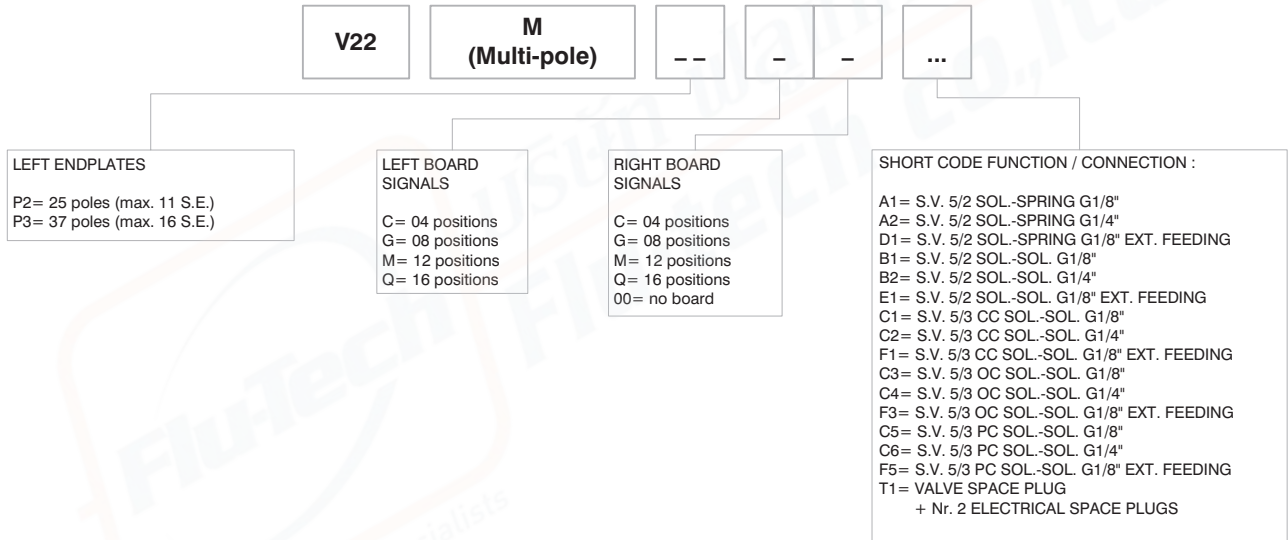

**Serial manifold layout (for the serial system node, see the Optyma-F Series)**

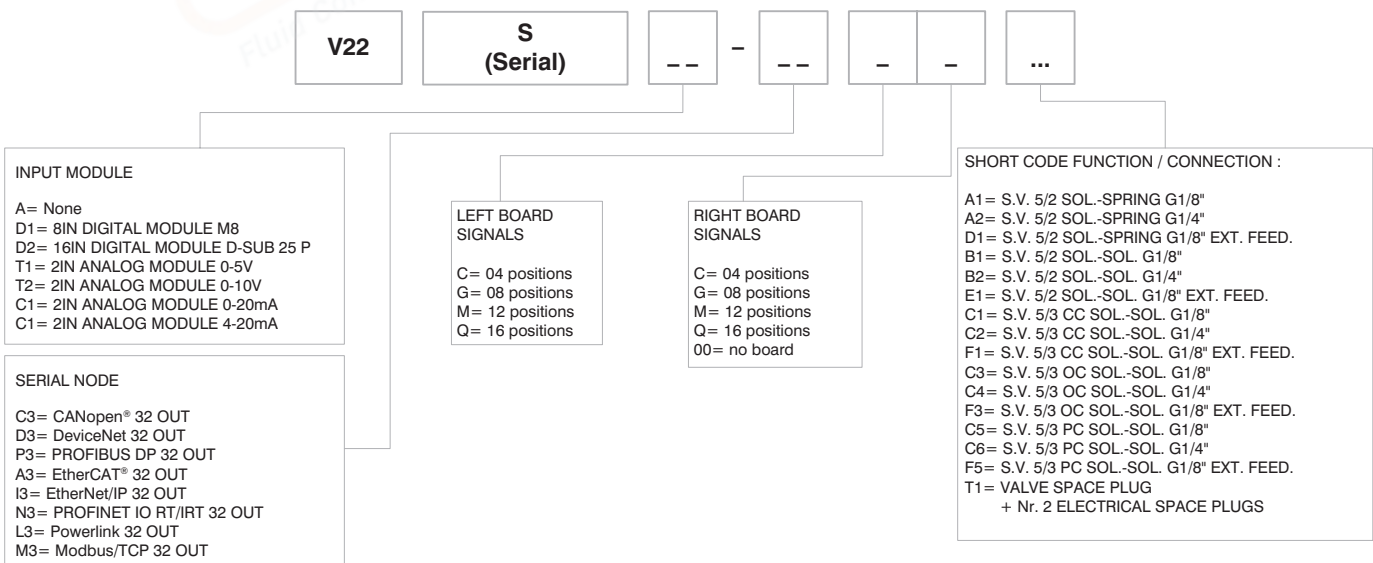

**NOTE:**

When constructing the configuration, please consider that the maximum number of valves that can be mounted on the manifold is 16, regardless of the valve type. Any valve position presents two electrical connections: in case of use of monostable valves (A1-A2) it will be necessary to assemble a plug to protect the unused electrical connection.

The correspondence between the electrical signal and its location on the manifold is showed in the following diagrams.

1  
AIR DISTRIBUTION

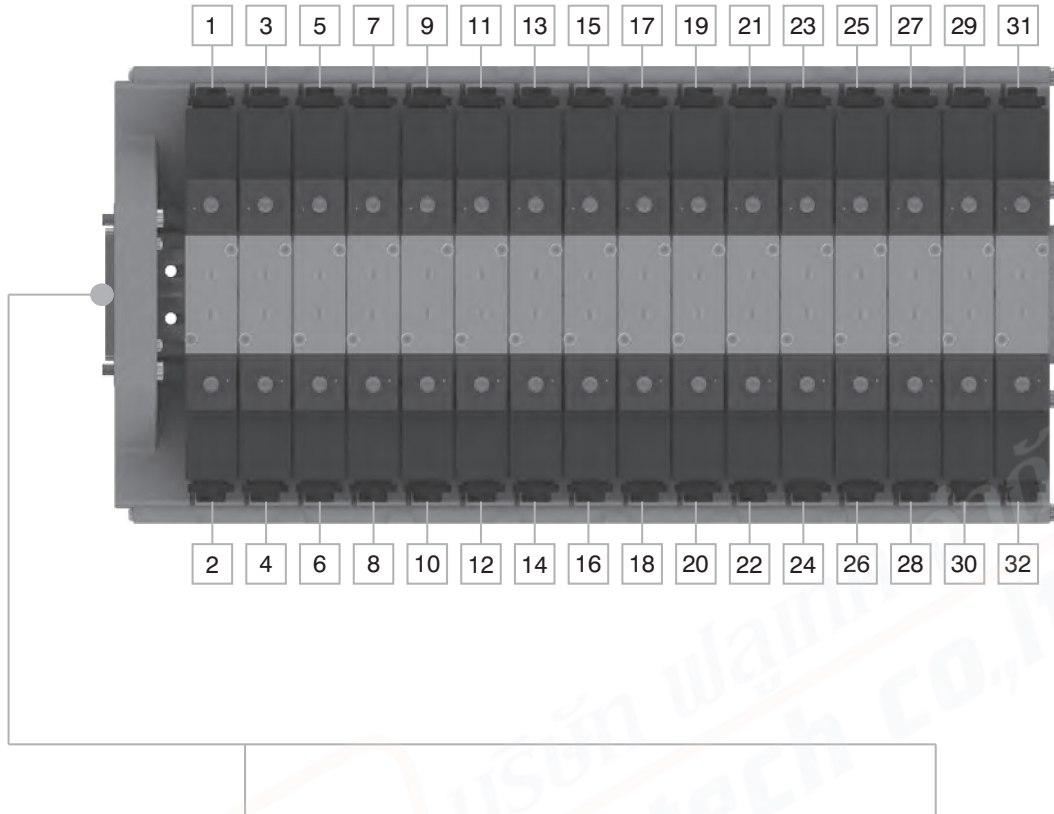

Connector 25 Poles from 1 to 11  
Positions E.V. Bistable / Monostable

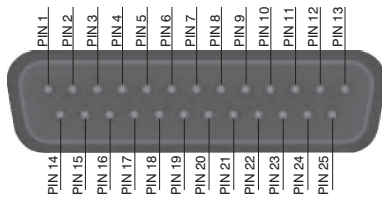

1 - 22 = SIGNALS  
23 - 24 = GND  
25 = NC

Connector 37 Poles from 1 to 16  
Positions E.V. Bistable / Monostable

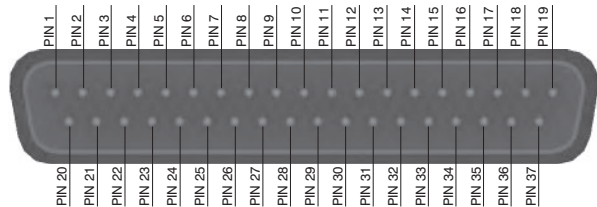

1 - 32 = SIGNALS  
33 - 35 = GND  
36 - 37 = NC

**Assembly sequence**

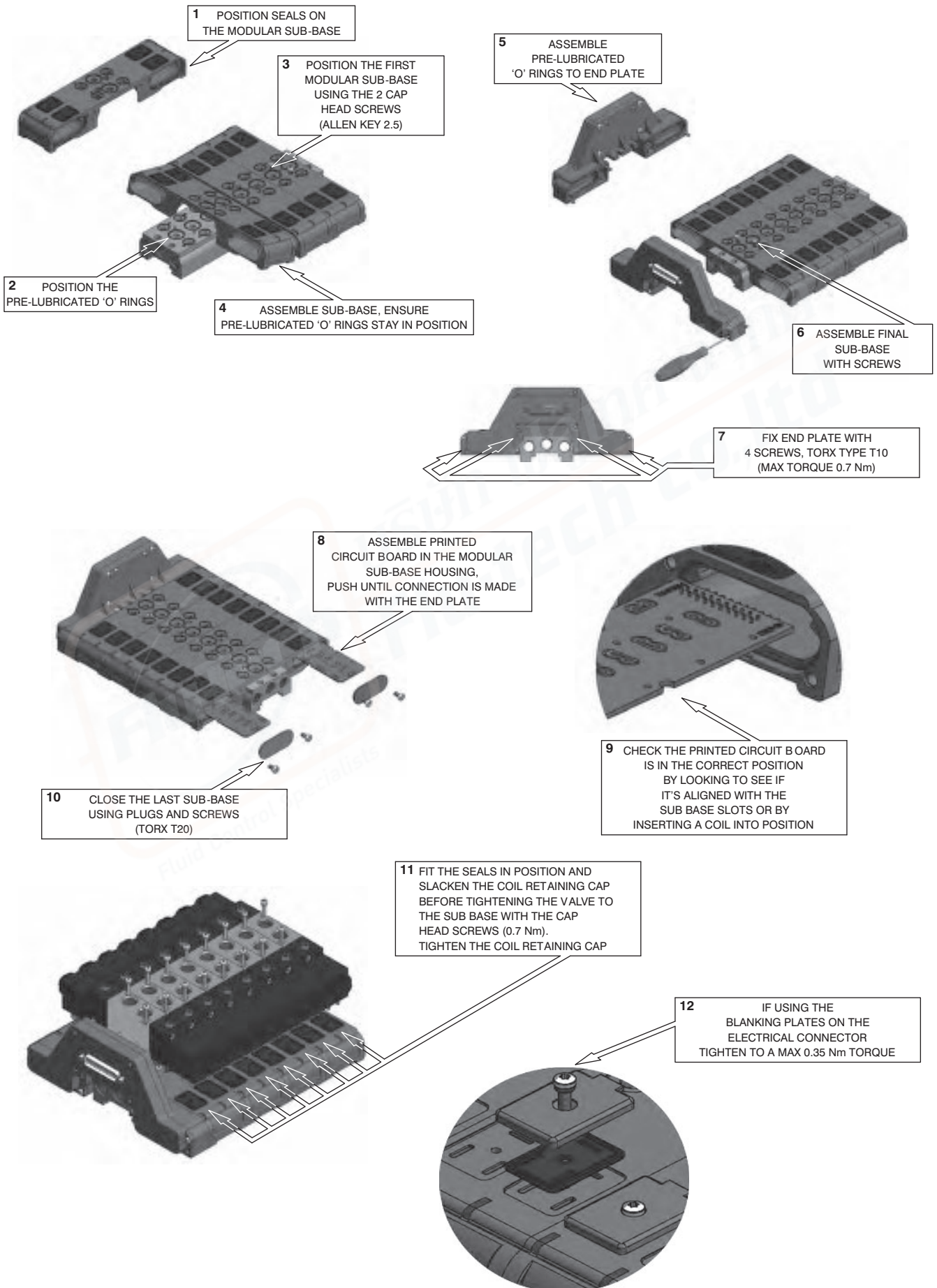

1  
AIR DISTRIBUTION