

Serie Valves

Valvole Elettropneumatiche

Solenoid Valve
 Elektropneumatische Ventile
 Distributeurs Elettropneumatiques
 Válvulas Electroneumáticas
 Válvulas Electro-pneumáticas



Serie 01V - X1V

Pag. 18.6 - 18.16

Valvole Asservite

Assisted Valve
 Ventile Vorgesteuert
 Distributeurs à Commande Assistée
 Válvula Asistida
 Válvula Piloto Externo



Serie 01V

Pag. 18.17 - 18.29

Valvole Pneumatiche

Pneumatic Valve
 Pneumatische Ventile
 Distributeurs Pneumatiques
 Válvulas Neumáticas
 Válvulas Pneumáticas



Serie 01V

Pag. 18.30 - 18.36

Valvole ad Azionamento Manuale

Manual Valve
 Manuell Betätigte Ventile
 Distributeurs à Commandes Manuel
 Válvulas de Accionamiento Manual
 Válvulas de Acionamento Manual



Serie 01V - X1V

Pag. 18.37 - 18.47

Valvole ad azionamento meccanico

Mechanically actuated valve
 Mechanisch betätigte ventile
 Distributeurs à commandes mécaniques
 Válvulas de accionamiento mecánico
 Válvula de accionamento mecánico



Serie 01V

Pag. 18.48 - 18.51

Basi Multiple

Multiple Bases
 Mehrfach Grundplatten
 Embases Multiples
 Base Múltiple
 Bases Múltiplas

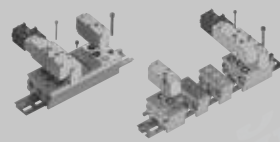

Serie 01V

Pag. 18.52 - 18.56

Micro Valvole

Micro Valves
 Mikroventile
 Microdistributeurs
 Microválvulas
 Micro-Válvulas



Serie 02V

Pag. 18.58 - 18.60

Valvole 16 mm

16 mm Valves
 Ventile 16 mm
 Distributeurs 16 mm
 Válvulas 16 mm
 Válvulas 16 mm



Serie 03V

Pag. 18.62 - 18.66

Valvole a Pannello, Pulsanti e Selettori

Panel Valve, Push Buttons and Selectors
 Schalttafelventile, Taster und Schalter
 Distributeurs pour commandes en panneau et boutons
 Válvulas de Panel, Pulsadores, Selectores
 Válvulas para Painel, Pulsantes e Seletoras



Serie 04V

Pag. 18.68 - 18.70

Valvole VDMA 18 mm

18 mm VDMA Valve
 Ventile 18 mm VDMA
 Distributeurs 18 mm VDMA
 Válvulas VDMA 18 mm
 Válvulas VDMA 18 mm



Serie 05V

Pag. 18.72 - 18.82

Valvole a Pedale

18 mm VDMA Valve
 Ventile 18 mm VDMA
 Distributeurs 18 mm VDMA
 Válvulas VDMA 18 mm
 Válvulas VDMA 18 mm

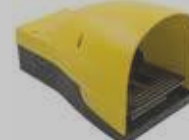

Serie 06V

Pag. 18.84 - 18.85

Elettropiloti

Pedal Valve
 Valvole a Pedale
 Distributeurs à Pédale
 Válvulas a Pedal
 Válvulas Pedal



Serie 07V

Pag. 18.87 - 18.89

Elettropiloti Miniaturizzati 10-15 mm

Miniature Solenoid Valve 10 - 15 mm
 Miniatur Ventile 10 - 15 mm
 Distributeurs Miniature au pluriel 10 - 15 mm
 Electropiloto Miniaturizado 10 - 15 mm
 Eletropilotos Miniaturizados 10 - 15mm



Serie 07V

Pag. 18.90 - 18.96

Valvole NAMUR

NAMUR Valve
 NAMUR Ventile
 Distributeurs NAMUR
 Válvulas NAMUR
 Válvulas NAMUR



Serie 08V

Pag. 18.98 - 18.106

Valvole ISO 5599 - Taglia 1

Valves ISO 5599 - Size 1
 Ventile ISO 5599 - Größe 1
 Distributeurs a tiroir ISO 5599 - Taille 1
 Válvulas ISO 5599 - Tamaño 1
 Válvulas ISO 5599 - Tamanho 1



New

Serie 10V

Pag. 18.108 - 18.112

Valvole ISO 5599 - Taglia 2

Valves ISO 5599 - Size 2
 Ventile ISO 5599 - Größe 2
 Distributeurs a tiroir ISO 5599 - Taille 2
 Válvulas ISO 5599 - Tamaño 2
 Válvulas ISO 5599 - Tamanho 2



New

Serie 11V

Pag. 18.114 - 18.118

Valvola a Leva Manuale

Rotary Hand Lever Valve
 Handhebeventil
 Distributeur a Commande Manuelle
 Válvula de Leva Manual
 Válvula de Alavanca Manual



Serie 12V

Pag. 18.120 - 18.121

Valvola Elettropneumatica Modulare

Modula Solenoid Valve
 Modulare Druckluft-elektromagnet-ventile
 Ilots de Distribution Pneumatique
 Válvulas Electroneumáticas Modulares
 Válvulas Eletropneumáticas Modulares



Serie 15V

Pag. 18.123 - 18.162

Solenoidi e Connettori

Solenoid and Connectors
 Magnetspulen und Stecker
 Bobines et Connecteurs
 Bobinas y Conectores
 Solenóides e Conectores



Pag. 18.24 - 18.29 / 18.75

VALVOLE ELETTROPNEUMATICHE, PNEUMATICHE E MANUALI

MANUAL, PNEUMATIC AND SOLENOID PILOT VALVES

MANUELLE, PNEUMATISCHE & ELEKTROPNEUMATISCHE VENTILE

DISTRIBUTEURS ÉLECTROPNEUMATIQUES, PNEUMATIQUES & MÉCANIQUES

VÁLVULAS ELECTRONEUMÁTICAS, NEUMÁTICAS Y MANUALES

VÁLVULAS ELETRO-PNEUMÁTICAS, PNEUMÁTICAS E MANUAIS



Serie Valves

VALVES



บริษัท ฟลูเทค จำกัด
FLU-TECH CO.,LTD

845/3-4 หมู่ 3 ถ.เทพารักษ์ ต.เทพารักษ์ อ.เมือง จ.สมุทรปราการ 10270

845/3-4 Thepharak RD., T.Thepharak, A.Muang, Samutprakarn 10270 THAILAND
Tel. 0 2384 6060, Fax 0 2384 5701, Email : sales@flutech.co.th, www.flutech.co.th

VALVOLE 01V

Le Valvole Aignep Serie 01V, elettriche, pneumatiche e manuali, sono robuste, versatili e combinano prestazioni elevate con ingombro contenuto.

Queste valvole sono caratterizzate da alta portata, tempi di commutazione ridotti e bassa pressione di commutazione.

Disponibili in 3 taglie, 1/8 - 1/4 e 1/2 sono progettate per pressioni di esercizio fino a 10 bar.

Sono disponibili manifold di distribuzione per la creazione di batterie dedicate.

Valvole ATEX:

- Ex II 2 GD c T6 -10°C<Tamb<60°C

Le Bobine a basso assorbimento sono disponibili in tutte le tensioni, sono disponibili versioni:

- ATEX II2G EX DMD IIC T5 GB

- UL1446 CAN/CSA C22.2

Principali vantaggi

- Estremamente durevole
- Alto flusso in dimensioni compatte
- Facile Installazione
- Amplia gamma
- Basso consumo

Applicazioni

- Automazione Pneumatica, Robotica e manipolazione
- Automotive Process
- Industria tessile, imballaggio, farmaceutica, pesante
- Food Process
- ATEX Zone

01V VALVES

The 01V valve range is robust, versatile and combines high performances with compact installation dimensions.

Solenoid, electrical, mechanical and manual operated.

Large flow capacity, short change-over times and low change-over pressure.

Available in 3 sizes: 1/8 - 1/4 e 1/2 .

They can operate up to 10 bar working pressure. Multiple manifolds to create your own valves block. Solenoid coils are energy-saving and available in all voltage.

Valves ATEX:

- Ex II 2 GD c T6 -10°C<Tamb<60°C

Solenoid coils according to ATEX II2G EX DMD IIC T5 GB and UL1446 CAN/CSA C22.2 are also available.

Main advantages

- Extremely Durable
- High Flow in Compact Dimension
- Easy Installation
- Large Range
- Energy Saving

Applications

- Pneumatic Automation, Robotics, Handling
- Automotive Process
- Textile, Packaging, Heavy Duty
- Food Process
- ATEX Zone

VENTILE 01V

Die 01V Ventilbaureihe ist robust, vielseitig und kombiniert hohe Leistung mit kompakten Einbaumassen.

Magnetisch, elektrisch, mechanisch und manuell betrieben. Grosse Durchflussleistung, kurze Umrüstzeiten und niedriger Umschaltdruck.

Erhältlich in 3 Größen: 1/8 - 1/4 und 1/2". Sie können mit bis zu 10 bar Betriebsdruck arbeiten.

Verschiedene Verteilerblöcke um Ihre eigenen Ventileblöcke zu erstellen. Magnetspulen sind energiesparend und in allen Spannungen erhältlich.

Ventile ATEX:

- Ex II 2 GD c T6 -10°C<Tamb<60°C

Magnetspulen nach ATEX II2G EX DMD IIC T5 GBe UL1446 CAN / CSA C22.2 sind ebenfalls erhältlich.

Hauptvorteile

- Extrem Dauerhaft
- Hohe Durchflussleistung in kompakte Abmessungen
- Einfache Montage
- Weites Spektrum
- Energieeinsparung

Anwendungen

- Pneumatische Automation, Robotik, Handling
- Automobil Prozess
- Textil-, Verpackungs-, Schwerlast-Industrie
- Lebensmittel Prozess
- ATEX Bereich

DISTRIBUTEUR 01V

La gamme des distributeurs 01V est robuste, polyvalente et offre des performances élevées dans des dimensions compactes. Disponibles en commande électrique, mécanique et manuelle. Grande capacité de débit, faibles temps et basse pression de commutation.

Disponibles en 3 tailles: 1/8 1/4 et 1/2, sont conçus pour des pressions de service jusqu'à 10 bar.

Les bobines et connecteurs complètent l'offre. Les bobines sont économes en énergie et disponibles dans toutes les tensions.

Distributeur ATEX:

- **Ex** II 2 GD c T6 -10°C < Tamb < 60°C

Bobines selon ATEX II2G EX DMD IIC T5 GB et UL 1446 CAN/CSA C22.2

Principaux avantages

- Longue durée de vie
- Haut débit avec dimension compact
- Facile d'installation
- Large gamme
- Faible consommation

Applications

- Automatismes pneumatiques, Robotique
- Process Automobile
- Industrie textile, l'emballage
- Process alimentaire
- Zone ATEX

VÁLVULAS 01V

Las válvulas Aignep Serie 01V, eléctricas, neumáticas y manuales, son robustas, versátiles y combinan elevadas prestaciones con dimensiones contenidas. Estas válvulas se caracterizan de gran caudal, tiempos de conmutación reducidos y baja presión de conmutación.

Disponibles en 3 tallas, 1/8 - 1/4 y 1/2 son proyectadas para presiones de ejercicio hasta 10 bar.

Están disponibles bases de distribución para la creación de baterías dedicadas.

Válvulas ATEX:

- **Ex** II 2 GD c T6 -10°C < Tamb < 60°C

Las bobinas de bajo consumo están disponibles en todas las tensiones, también disponibles versiones ATEX II2G EX DMD IIC T5 GB y UL 1446 CAN/CSA C22.2

Principales ventajas

- Extremadamente Durable
- Alto Caudal en dimensiones compactas
- Fácil instalación
- Amplia Gama
- Bajo Consumo

Aplicaciones

- Automatización neumática, robótica y manipulación
- Procesos de automoción
- Industria textil, embalaje, farmacéutica, pesada
- Alimentaria
- Zona ATEX

VÁLVULAS 01V

As Válvulas Aignep Série 01V, eléctricas, pneumáticas e manuais, são robustas, versáteis e combinam performance elevada com tamanho reduzido. Estas válvulas são caracterizadas por alta vazão, tempos de comutação reduzidos e baixa pressão de comutação.

Disponíveis em 3 tamanhos, 1/8" - 1/4" e 1/2" são projetadas para pressões de trabalho de até 10 bar.

São disponíveis manifolds para montagens de baterias de válvulas dedicadas.

Válvulas ATEX:

- **Ex** II 2 GD c T6 -10°C < Tamb < 60°C

As bobinas estão disponíveis em todas as tensões, e nas versões ATEX II2G EX DMD IIC T5 GB e UL 1446 CAN/CSA C22.2

Principais Vantagens

- Extremamente durável
- Alto fluxo em com reduzidas dimensões
- Instalação fácil
- Ampla Gama
- Economia de Energia

Aplicações

- Automações Pneumática, Robótica e manipulação
- Processos Automotivos
- Indústria têxtil, embalagem, farmacêutica, industria pesada
- Processos Alimnetícios
- Aprovação ATEX



บริษัท ฟลูเทค จำกัด
FLU-TECH CO.,LTD

845/3-4 หมู่ 3 ถ.เทพารักษ์ ต.เทพารักษ์ อ.เมือง จ.สมุทรปราการ 10270

845/3-4 Thepharak RD., T.Thepharak, A.Muang, Samutprakarn 10270 THAILAND
Tel. 0 2384 6060, Fax 0 2384 5701, Email : sales@flutech.co.th, www.flutech.co.th

MICROVALVOLE

MICROVALVE

MIKROVENTILE

MICRODISTRIBUTEURS

MICROVÁLVULAS

MICRO-VÁLVULA



MICROVALVOLE

MICROVALVE
MIKROVENTILE
MICRODISTRIBUTEURS
MICROVÁLVULAS
MICRO-VÁLVULA



CARATTERISTICHE TECNICHE

TECHNICAL CHARACTERISTICS
TECHNISCHE ANGABEN
CARACTÉRISTIQUES TECHNIQUES
CARACTERÍSTICAS TÉCNICAS
CARACTERÍSTICAS TÉCNICAS



Norma di Riferimento

Reference standard

Entspricht der Norm

Norme de référence

Normativa de referencia

Norma de referência

1907/2006
REACH ✓

2011/65/CE
RoHS ✓

PED
2014/68/UE



		M5
	ATTACCO FILETTATO THREADED ANSCHLUSS CONNEXION ROSCA CONEXÃO ROSCADA	M5
	PORTATA a 6 BAR con Δp 1 bar 6 bar FLOW RATE with Δp 1 bar DURCHFLUSSWERT BEI 6 bar mit Δp 1 bar DÉBIT DE RÉFÉRENCE à 6 bar avec Δp 1 bar CAUDAL a 6 BAR con Δp 1 bar VAZÃO a 6 BAR com Δp 1 bar	100 NI/min
	PRESSIONE DI FUNZIONAMENTO OPERATING PRESSURE BETRIEBSDRUCK PRESSION DE SERVICE PRESIÓN DE EJERCICIO PRESSÃO DE OPERAÇÃO	2 ÷ 10 bar
	FORZA DI AZIONAMENTO DRIVING FORCE BETÄTIGUNGSDRUCK FORCE D'ACTIONNEMENT FUERZA DE ACCIONAMIENTO FORÇA DE ACIONAMENTO	6 N
	TEMPERATURA TEMPERATURE BETRIEBSTEMPERATUR TEMPÉRATURE DE TRAVAIL TEMPERATURA TEMPERATURA	min -10 °C
		max +60 °C

Materiali e Componenti	IT	Component Parts and Materials	GB
1 Corpo in alluminio anodizzato 2 Molla in acciaio INOX 3 Guarnizioni in NBR		1 Anodised aluminium body 2 Stainless Steel Spring 3 NBR seals	
Komponenten und Materialien	DE	Matériaux et Composants	FR
1 Aluminiumgehäuse Eloxiert 2 Feder Edelstahl 3 Dichtungen Aus NBR		1 Corps en aluminium anodisé 2 Ressort Acier INOX 3 Joints en NBR	
Materiales y Componentes	ES	Materiais e Componentes	PT
1 Cuerpo en Aluminio Anodizado 2 Muelle en Acero INOX 3 Juntas en NBR		1 Corpo em Alumínio Anodizado 2 Mola em Aço INOX 3 Vedação em NBR	



Tabella dei codici di ordinazione

Ordering codes

Bestellschlüssel

Code de commande

Tabla de codificación para pedidos

Tabela de codificação para compra

SERIE	Azionamento Actuation Betätigung Actionnement Accionamiento Acionamento	Riazionamento Reactuation Rückstellung Rappel Reaccionamiento Retorno	Vie Ways Wege Voies Vías Vias	Funzione Function Funktion Fonction Función Funções	Misura Size Größe Dimension Medida Tamanho
-------	--	--	--	--	---

0 2 V

G

0

3

N C

B 5

G = Puntale
Tappet
Stößel
Poussoir
Puntal
Direto no pino

R = Rullo corto
Short Roller
Rollenhebel
Levier à galet
Rodillo corto
Rolete curto

U = Rullo Unidirezionale
Uni-directional Roller
Kipphebel
Levier à galet escamotable
Rodillo Unidireccional
Rolete Unidireccional

E = Puntale passa parete
Panel Mounting Taper
Microvalve
Stößel, Schalttafeleinbau
Poussoir, montage en panneau
Puntal Pasa Tabiques
Passa-muro - direto no pino

0 = Monostabile con ritorno a molla
Monostable spring return
Monostabil mit Federrückstellung
Monostable à rappel par ressort
Monoestable con retorno muelle
Monoestável com retorno por mola

3 = 3/2

NO = Normalmente aperta
Normally open
Normalerweise offen
Normalement ouvert
Normalmente abierta
Normalmente aberta

NC = Normalmente chiusa
Normally closed
Normalerweise geschlossen
Normalement fermé
Normalmente cerrada
Normalmente fechada

B5 = M5

3/2 Vie - Ways - Wege - Voies - Vías - Vias

MICROVALVOLE A PUNTALE

TAPPET MICROVALVE

STÖßEL - MIKROVENTIL

MICRODISTRIBUTEUR À POUSSOIR

MICROVÁLVULA DE PUNTAL

MICRO-VÁLVULAS DE ACIONAMENTO DIRETO NO PINO

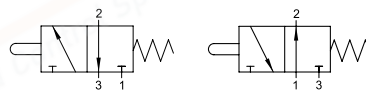

NC

NO



Codice Code Nummer Code Código Código	Vie Ways Wege Voies Vías Vias	Funzione Function Funktion Fonction Función Funções	Misura Size Größe Dimension Medida Tamanho	Pack.
02V G0 3 NC B5	3/2	NC	M5	1
02V G0 3 NO B5	3/2	NO	M5	1

3/2 Vie - Ways - Wege - Voies - Vías - Vias

MICROVALVOLE A RULLO CORTO

SHORT ROLLER MICROVALVE

ROLLENHEBEL - MIKROVENTIL

MICRODISTRIBUTEUR À LEVIER À GALET

MICROVÁLVULA DE RODILLO CORTO

MICRO-VÁLVULA DE ROLETE CURTO

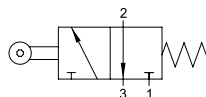

Codice Code Nummer Code Código Código	Vie Ways Wege Voies Vías Vias	Funzione Function Funktion Fonction Función Funções	Misura Size Größe Dimension Medida Tamanho	Pack.
02V R0 3 NC B5	3/2	NC	M5	1



3/2 Vie - Ways - Wege - Voies - Vías - Vias

MICROVALVOLE A RULLO UNIDIREZIONALE

UNI-DIRECTIONAL ROLLER MICROVALVE

KIPPEBEL - MIKROVENTIL

MICRODISTRIBUTEUR À LEVIER À GALET ESCAMOTABLE (UNIDIRECTIONNEL)

MICROVÁLVULA DE RODILLO UNIDIRECCIONAL

MICRO-VÁLVULA DE ROLETE UNIDIRECCIONAL

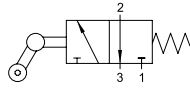

Codice Code Nummer Code Código Código	Vie Ways Wege Voies Vías Vias	Funzione Function Funktion Funktion Función Funções	Misura Size Größe Dimension Medida Tamanho	Pack.
02V U0 3 NC B5	3/2	NC	M5	1

3/2 Vie - Ways - Wege - Voies - Vías - Vias

MICROVALVOLE A PUNTALE PASSAPARETE

PANEL MOUNTING TAPPET MICROVALVE

STÖBEL - MIKROVENTIL, SCHALTTAFELEINBAU

MICRODISTRIBUTEUR À POUSSOIR, MONTAGE EN PANNEAU

MICROVÁLVULA DE PUNTAL PASATABIQUES

MICRO-VÁLVULA PASSA-MURO - ACIONAMENTO DIRETO NO PINO

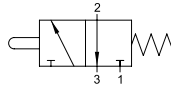

Codice Code Nummer Code Código Código	Vie Ways Wege Voies Vías Vias	Funzione Function Funktion Funktion Función Funções	Misura Size Größe Dimension Medida Tamanho	Pack.
02V E0 3 NC B5	3/2	NC	M5	1

02V G0 3 NC B5

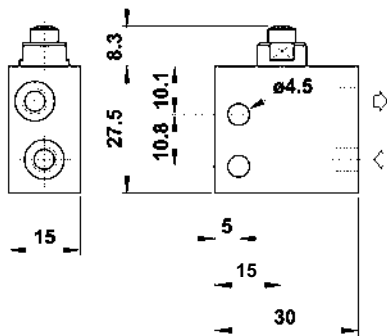

02V R0 3 NC B5

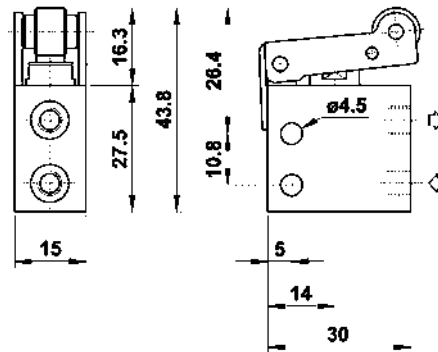

02V U0 3 NC B5

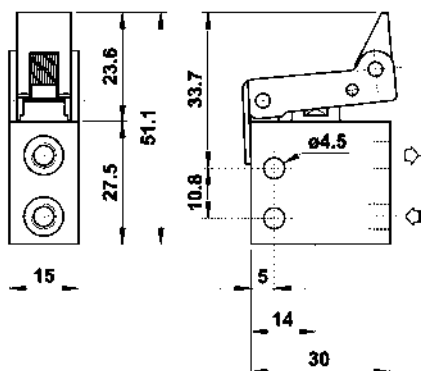

02V E0 3 NC B5

