

SENTRY Slide Lockout Valves

V10 Models Port Sizes: 1/8, 1/4 Tube Fittings

Model Shown: V10-2



- ◆ 3-Way lockout valve specifically for use with **SENTRY FRL's**
- ◆ Threaded ports or quick-connect fittings for tubing up to 10 mm in diameter.
- ◆ Available pre-assembled on **FRL** assembly, or as a single component for retrofitting in the field.
- ◆ Can be padlocked only in the closed position.
- ◆ Slide moves smoothly even after long period on standby.
- ◆ **NPTF** port threads; optional **BSPP** threads or tube fittings.

SPECIFICATIONS

Ambient/Media Temperature:

40° to 125°F (4° to 52°C).

Elastomers: Nitrile.

Fluid Media: Compressed air.

Inlet Pressure: 150 psig (10 bar) maximum.

Screws: Zinc-plated steel.

Slide: Acetal.

Valve Color: Yellow.

FLOW CHART

Inlet Pressure: 100 psig (7 bar)

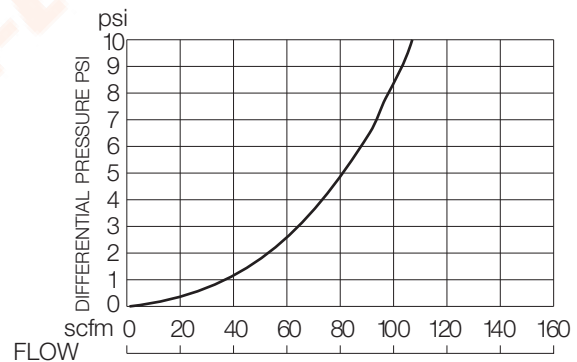

VALVE OPERATION

VALVE OPEN

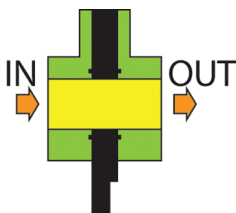

With the yellow slide depressed, supply air flows freely from inlet to outlet, and flow to the exhaust is blocked. The slide cannot be padlocked in the open position so that it is always ready for immediate closing.

VALVE CLOSED

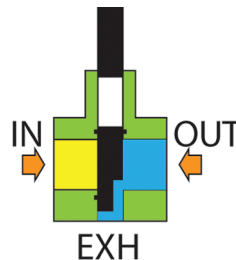

With the slide fully pushed out, supply air is blocked from the outlet, and downstream air is exhausted via the opening at the bottom of the valve. The slide can be padlocked in the closed position.



บริษัท ฟลูเทค จำกัด
FLU - TECH CO., TD

845/3-4 หมู่ 3 ถ.เทพารักษ์ ต.เทพารักษ์ อ.เมือง จ.สมุทรปราการ 10270
845/3-4 Thepharak RD., T. Thepharak, A. Muang, Samutprakan 10270 THAILAND
Tel. 0 2384 6060, Fax 0 2384 5701, Email : sales@flutech.co.th, www.flutech.co.th

DIMENSIONS inches (mm)

Ports	A	B	C
No Ports	1.8 (45)	2.3 (57)	0.6 (14)
1/8, 1/4	1.8 (45)	2.5 (64)	2.0 (51)

Models below have quick-connect fittings for tubing.

1/4	1.8 (45)	2.5 (64)	2.3 (58)
3/8	1.8 (45)	2.5 (64)	2.9 (74)
4 mm	1.8 (45)	2.5 (64)	2.5 (64)
6 mm	1.8 (45)	2.5 (64)	2.1 (53)
8 mm	1.8 (45)	2.5 (64)	2.1 (53)
10 mm	1.8 (45)	2.5 (64)	2.9 (74)

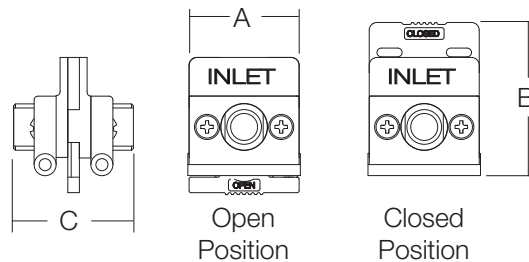

ASSEMBLED SENTRY UNITS

Assembled **SENTRY FRLs** with V10 lockout at the inlet can be ordered. Model VCFDRL10-2 is shown below.

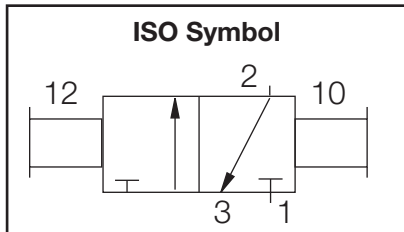

WALL MOUNTING: To mount a complete valve with threaded ports or tube fittings, use two 10-24 x 2-1/4" pan-head Philips screws (Part number 10R-19)

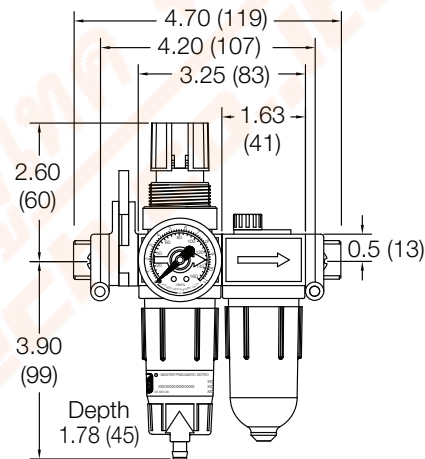

ORDERING INFORMATION

Change the letters in the sample model number below to specify the valve you want. To order V10 lockouts installed on a **SENTRY FRL**, see Options on **FRL** pages.

V10 P - 1 X W

MOUNTING HOLE LOCATION

Bottom mount (Standard) Leave Blank
 Top mount P

PORT TYPE

As specified in **INLET PORT** Leave Blank
 BSSP threads on both ports W

INLET PORT SIZE

No Inlet and Outlet fittings..... Leave Blank
 Includes seals and screws for retrofitting.

OUTLET PORT SIZE

Same as inlet port.....Leave Blank

Threaded:

1/8 NPTF -1
 1/4 NPTF -2

Threaded:

1/8 NPTF 1
 1/4 NPTF 2

Fittings for Tubing:

1/4 -04
 3/8 -06
 4 mm -M4
 6 mm -M6
 8 mm -M8
 10 mm -M10

Fittings for Tubing:

1/4 04
 3/8 06
 4 mm M4
 6 mm M6
 8 mm M8
 10 mm M10

