

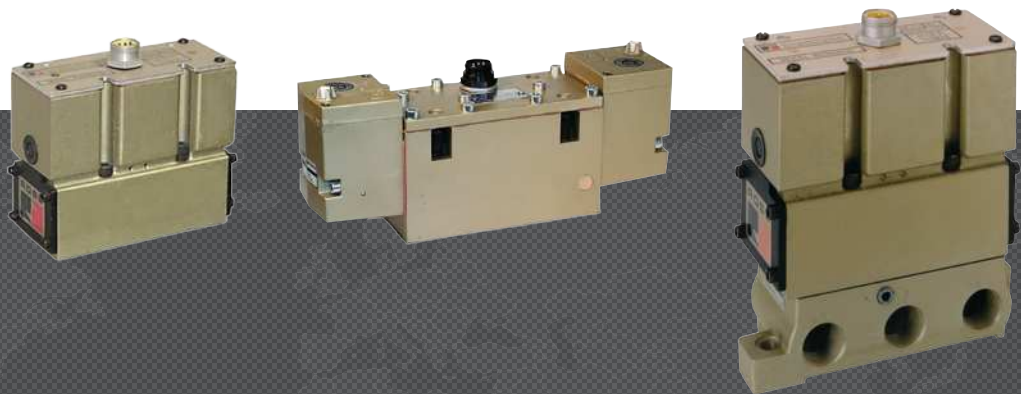

# DIRECTIONAL CONTROL SAE VALVES 80 & 84 SERIES

## PRODUCT CATALOG



# SAE Valves 80 Series

## Product Overview

The ROSS® SAE valves 80 Series are base mounted spool and sleeve valves, designed to conform to the standards of the Society of Automotive Engineers (SAE), this makes the valves for SAE bases interchangeable.

These SAE Size 125, 250, and 500 valves are available as, 2- and 3-position, 5-ported 4-way solenoid pilot valves with either internal or external pilot supply. The spool and sleeve design means there are no seals to wear out.

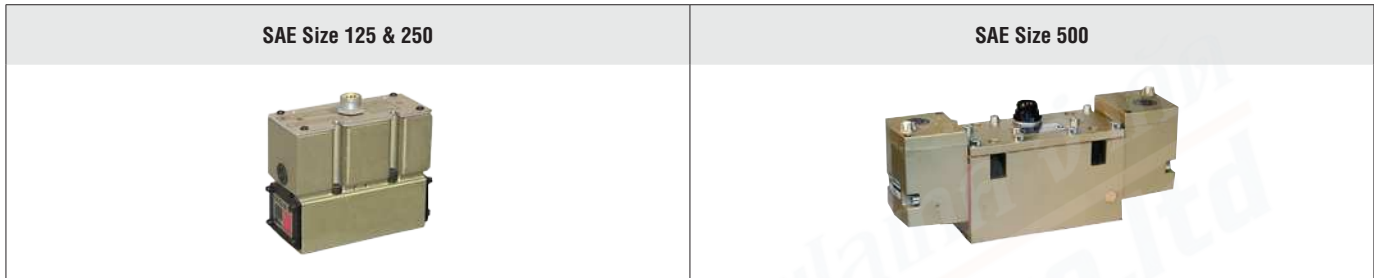

Illustration examples.

### VALVE FEATURES

<b>Spool Design</b>	Balanced spool; no seals to wear out
<b>Mounting Options</b>	Individual sub-base or manifold base mounting
<b>Pilot Supply</b>	Internal or external; suitable for vacuum service (with external pilot supply)
<b>External Pilot Supply</b>	Easily field-convertible for use with an external pilot supply
<b>Pilot Operation</b>	Provides high shifting force with low power consumption

SAE Size	Available Inlet Port Sizes					Functions					Actuation	Maximum Flow C <sub>v</sub>	Page
	1/4	3/8	1/2	3/4	1	5/2		5/3					
						Single	Double	Closed Center	Open Center	Pressure Center			
125	●	●				●	●	●	●	●	●	1.0	3 – 9
250		●	●	●		●	●	●	●	●	●	2.5	
500			●	●	●	●	●	●	●		●	4.2	
<b>Sub-Bases &amp; Manifold Bases</b>												16 – 20	
<b>Accessories and Options</b>												21	

## STANDARD SPECIFICATIONS

<b>GENERAL</b>	Function		5/2 and 5/3 Valve	
	Construction Design		Spool and Sleeve	
	Actuation		Electrical – Solenoid Pilot Controlled	
	Mounting	Type	Base	
		Orientation	Any	
	Connection		Valve	Valve-to-base interface
			Sub-Base, Manifold	Threaded; NPT
Manual Override		Flush; rubber, non-locking		
Solenoid Indicator Light		One per solenoid		

<b>OPERATING CONDITIONS</b>	Temperature	Ambient	40° to 120°F (4° to 50°C)
		Media	40° to 175°F (4° to 80°C)
	Flow Media	Filtered air	
	Operating Pressure	Vacuum to 150 psig (Vacuum to 10 bar)	
	Pilot Supply Pressure	Minimum 15 psig (1 bar)	
External Pilot Supply		Must be equal to or greater than inlet pressure	

<b>ELECTRICAL DATA FOR SOLENOID PILOT</b>	Solenoids		Rated for continuous duty	
	Operating Voltage (each solenoid)		24 volts DC 100-120 volts AC, 50/60 Hz 230-240 volts AC, 50/60 Hz	
	Power Consumption	SAE Size 125 & 250	24 V DC – 8 watts 100-130 V AC – 8 VA inrush, 6 VA holding 230-240 V AC – 8 VA inrush, 6 VA holding	
		SAE Size 500	24 V DC – 14 watts 110-120 V AC – 87 VA inrush, 30 VA holding 230-240 V AC – 87 VA inrush, 30 VA holding	

<b>CONSTRUCTION MATERIAL</b>	Valve Body	Cast Aluminum	
	Spool	Stainless Steel	
	Seals	Buna-N	

**IMPORTANT NOTE:** Please read carefully and thoroughly all of the CAUTIONS, WARNINGS on the inside back cover.

## PRODUCT CREDENTIALS

<p>CSA Certificate of Compliance</p>	<p>CE Conformity Declaration</p>	<p>EAC Conformity Declaration</p>
--	--------------------------------------	---------------------------------------

# Ordering Information

## 5/2 Single Solenoid Pilot Controlled Valves

### SINGLE SOLENOID PILOT CONTROLLED VALVES

### 5-Way 2-Position Valves

Wiring Type	Connector Type	SAE Size	Valve Model Number*		
			Voltage		
			24 V DC	120 V AC	230 V AC
Chrysler Stellantis Wired	mini-connector 5-pin	125	8076C3341W	8076C3341Z	8076C3341Y
		250	8076C4341W	8076C4341Z	8076C4341Y
		500	8076B6341W	8076B6341Z	8076B6341Y
	micro-connector 5-pin	125	8076C3321	8076C3311	–
		250	8076C4321	8076C4311	–
		500	8076B6321	8076B6311	–
Ford Wired	mini-connector 5-pin	125	8076C3331W	8076C3331Z	8076C3331Y
		250	8076C4331W	8076C4331Z	8076C4331Y
		500	8076B6331W	8076B6331Z	8076B6331Y
	micro-connector 4-pin	125	8076C3361	–	–
		250	8076C4361	–	–
		500	8076B6361	–	–
Hardwire		125	8076C3351W	8076C3351Z	8076C3351Y
		250	8076C4351W	8076C4351Z	8076C4351Y
		500	8076B6351W	8076B6351Z	8076B6351Y

For other voltages, consult ROSS.

\* Sub-bases and manifold bases ordered separately. Please see Sub-Bases and Manifolds pages.

Pressure Controlled Spool & Sleeve Valves for SAE available, consult ROSS.

SAE Size	Flow C <sub>v</sub>	Average Response Constants*			Weight lb (kg)
		1-2	M	F	
	1-2			2-3	
125	1.4	20	3.5	4.9	3.5 (1.6)
250	4.0	10	1.4	2.6	6.5 (2.9)
500	8.2	22	0.5	0.8	8.3 (3.7)

**Valve Response Time** – Response Time (msec) = M + (F • V). This is the average time required to fill a volume V (cubic inches) to 90% of supply pressure or to exhaust it to 10% of supply pressure. M and F values are shown above.

#### Valve Schematic



## 5/2 Single Solenoid Pilot Controlled Valves

### DIMENSIONS

Inches (mm)

SAE Size 125

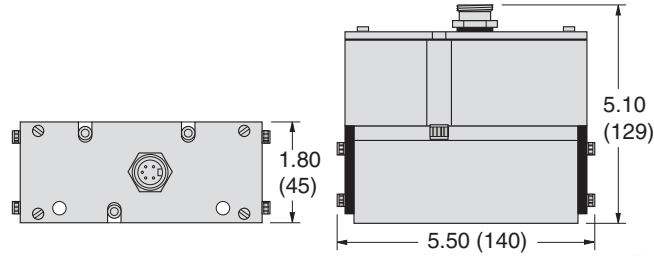

SAE Size 250

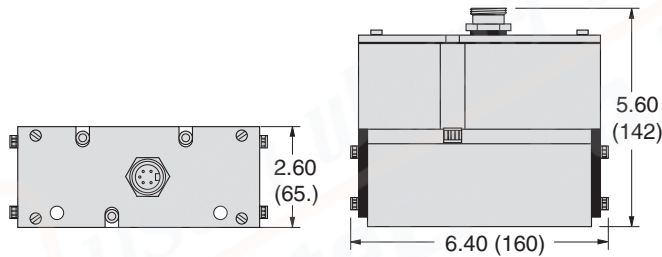

SAE Size 500

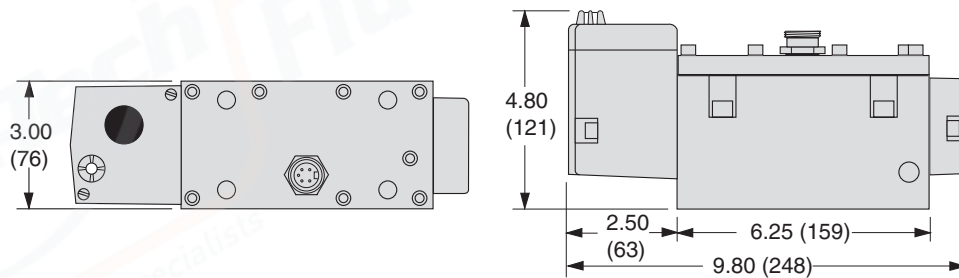

For additional information, and to assist you with piping and connectivity designs, our products are available in downloadable 2D drawings and 3D CAD models in a wide range of options including native formats. Please visit [www.rosscontrols.com](http://www.rosscontrols.com).

### Wiring Diagrams

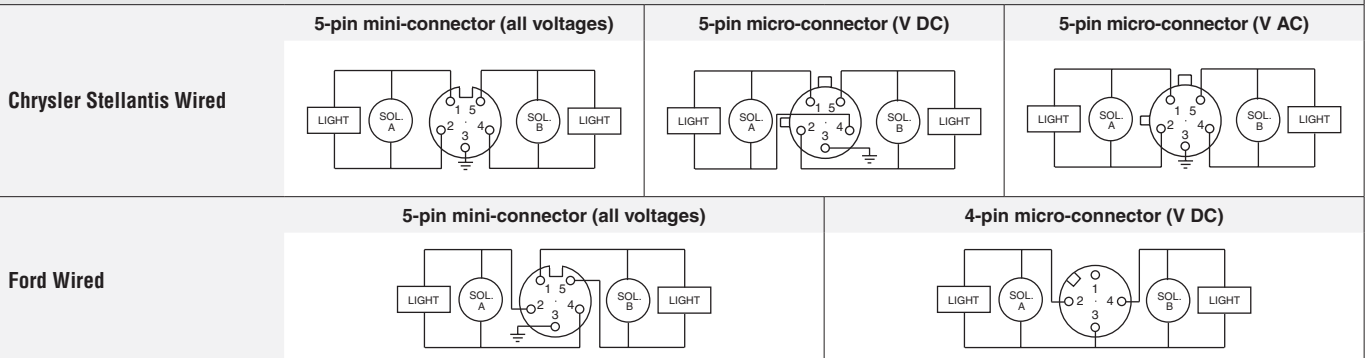

# Ordering Information

## 5/2 Double Solenoid Pilot Controlled Valves

### DOUBLE SOLENOID PILOT CONTROLLED VALVES

### 5-Way 2-Position Valves

Wiring Type	Connector Type	SAE Size	Valve Model Number*		
			Voltage		
			24 V DC	120 V AC	230 V AC
Chrysler Stellantis Wired	mini-connector 5-pin	125	8076C3342W	8076C3342Z	8076C3342W
		250	8076C4342W	8076C4342Z	8076C4342Y
		500	8076B6342W	8076B6342Z	8076B6342Y
	micro-connector 5-pin	125	8076C3322	8076C3312	–
		250	8076C4322	8076C4312	–
		500	8076B6322	8076B6312	–
Ford Wired	mini-connector 5-pin	125	8076C3331W	8076C3331Z	8076C3331Y
		250	8076C4331W	8076C4331Z	8076C4331Y
		500	8076B6331W	8076B6331Z	8076B6331Y
	micro-connector 4-pin	125	8076C3362	–	–
		250	8076C4362	–	–
		500	8076B6362	–	–
Hardwire		125	8076C3352W	8076C3352Z	8076C3352Y
		250	8076C4352W	8076C4352Z	8076C4352Y
		500	8076B6352W	8076B6352Z	8076B6352Y

For other voltages, consult ROSS.

\* Sub-bases and manifold bases ordered separately. Please see Sub-Bases and Manifolds pages.

Pressure Controlled Spool & Sleeve Valves for SAE available, consult ROSS.

SAE Size	Flow C <sub>v</sub>	Average Response Constants*			Weight lb (kg)	
		1-2	M	F		
				1-2		2-3
125	1.4	15	3.5	4.9	3.5 (1.6)	
250	4.0	17	1.5	2.6	7.0 (3.2)	
500	8.0	30	0.4	0.5	9.5 (4.3)	

**Valve Response Time** – Response Time (msec) = M + (F • V). This is the average time required to fill a volume V (cubic inches) to 90% of supply pressure or to exhaust it to 10% of supply pressure. M and F values are shown above.

#### Valve Schematic

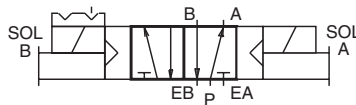

## 5/2 Double Solenoid Pilot Controlled Valves

### DIMENSIONS

Inches (mm)

SAE Size 125

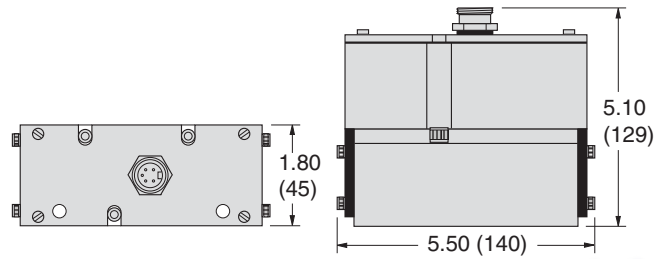

SAE Size 250

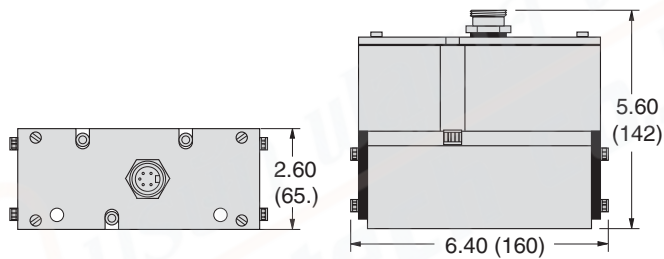

SAE Size 500

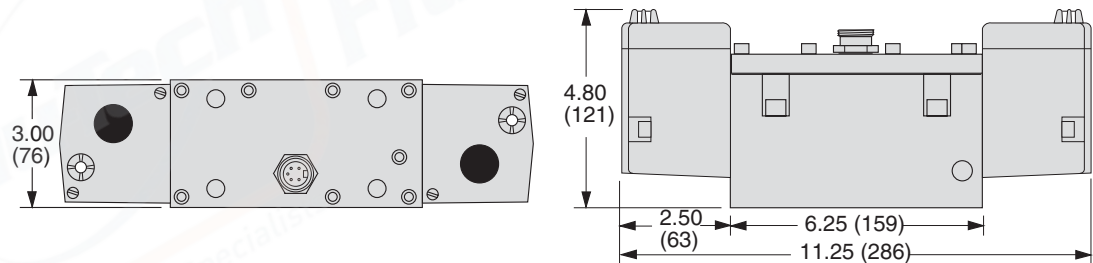

For additional information, and to assist you with piping and connectivity designs, our products are available in downloadable 2D drawings and 3D CAD models in a wide range of options including native formats. Please visit [www.rosscontrols.com](http://www.rosscontrols.com).

### Wiring Diagrams

	5-pin mini-connector (all voltages)	5-pin micro-connector (V DC)	5-pin micro-connector (V AC)
Chrysler Stellantis Wired			
Ford Wired			

# Ordering Information

## 5/3 Double Solenoid Pilot Controlled Valves

### DOUBLE SOLENOID PILOT CONTROLLED VALVES

### 5-Way 3-Position Valves

Wiring Type	Connector Type	SAE Size	SAE Size	Valve Model Number*		
				Voltage		
				24 V DC	120 V AC	230 V AC
Chrysler Stellantis Wired	mini-connector 5-pin	Power Center	125	8077B3904W	8077B3904Z	8077B3904Y
			250	8077A4904W	8077A4904Z	8077A4904Y
		Closed Center	125	8077C3341W	8077C3341Z	8077C3341Y
			250	8077C4341W	8077C4341Z	8077C4341Y
			500	8077B6341W	8077B6341Z	8077B6341Y
		Open center	125	8077C3342W	8077C3342Z	8077C3342Y
	250		8077C4342W	8077C4342Z	8077C4342Y	
	500		8077B6342W	8077B6342Z	8077B6342Y	
	micro-connector 5-pin	Closed Center	125	8077C3321	8077C3311	–
			250	8077C4321	8077C4311	–
			500	8077B6321	8077B6311	–
		Open center	125	8077C3322	8077C3312	–
			250	8077C4322	8077C4312	–
			500	8077B6322	8077B6312	–
Ford Wired	mini-connector 5-pin	Power Center	250	8077B3910W	8077B3910Z	8077B3910Y
			500	8077A4907W	8077A4907Z	8077A4907Y
		Closed Center	125	8077C3331W	8077C3331Z	8077C3331Y
			250	8077C4331W	8077C4331Z	8077C4331Y
			500	8077B6331W	8077B6331Z	8077B6331Y
		Open center	125	8077C3332W	8077C3332Z	8077C3332Y
	250		8077C4332W	8077C4332Z	8077C4332Y	
	500		8077B6332W	8077B6332Z	8077B6332Y	
	micro-connector 4-pin	Closed Center	125	8077C3361	–	–
			250	8077C4361	–	–
			500	8077B6361	–	–
		Open center	125	8077C3362	–	–
250			8077C4362	–	–	
500			8077B6362	–	–	
Hardwire	Closed Center	125	8077C3351W	8077C3351Z	8077C3351Y	
		250	8077C4351W	8077C4351Z	8077C4351Y	
		500	8077B6351W	8077B6351Z	8077B6351Y	
	Open center	125	8077C3352W	8077C3352Z	8077C3352Y	
		250	8077C4352W	8077C4352Z	8077C4352Y	
		500	8077B6352W	8077B6352Z	8077B6352Y	

For other voltages, consult ROSS.

\* Sub-bases and manifold bases ordered separately. Please see Sub-Bases and Manifolds pages.

Pressure Controlled Spool & Sleeve Valves for SAE available, consult ROSS.

### Valve Schematic

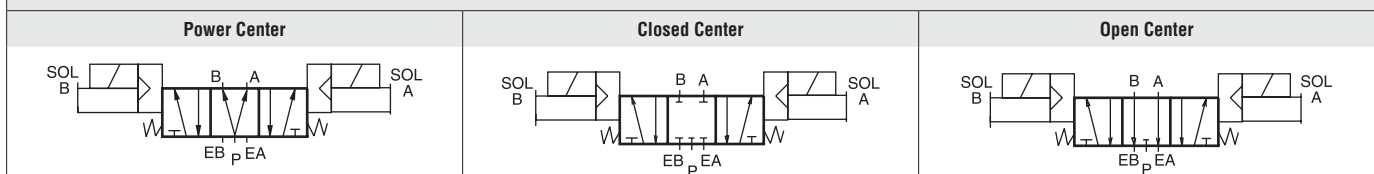



## 5/3 Double Solenoid Pilot Controlled Valves

### DIMENSIONS

Inches (mm)

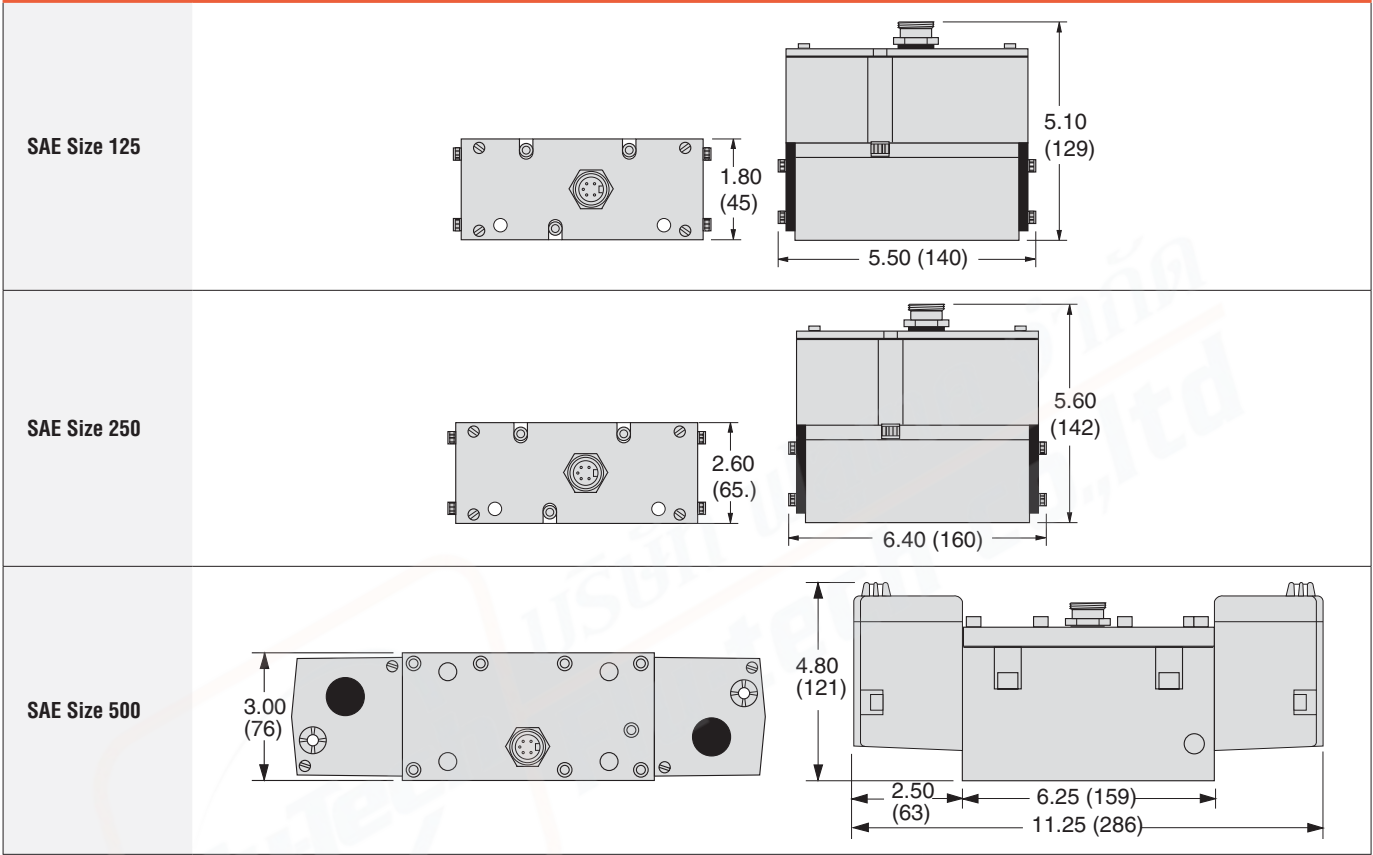

For additional information, and to assist you with piping and connectivity designs, our products are available in downloadable 2D drawings and 3D CAD models in a wide range of options including native formats. Please visit [www.rosscontrols.com](http://www.rosscontrols.com).

SAE Size	Flow $C_v$	Average Response Constants*		Weight lb (kg)	
	1-2	M	F		
			1-2		2-3
125	1.4	20	3.5	5.2	3.5 (1.6)
250	4.0	10	1.4	2.6	7.0 (3.2)
500	8.0	12	0.5	0.8	9.5 (4.3)

**Valve Response Time** – Response Time (msec) =  $M + (F \cdot V)$ . This is the average time required to fill a volume V (cubic inches) to 90% of supply pressure or to exhaust it to 10% of supply pressure. M and F values are shown above.

### Wiring Diagrams

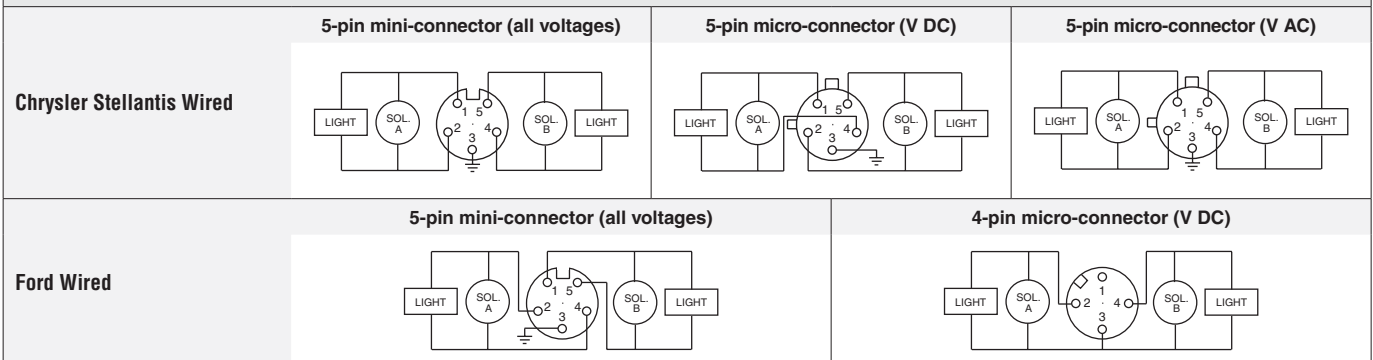

# SAE Valves 84 Series

## Product Overview

The ROSS® SAE valves 84 Series are base mounted poppet valves, designed to conform to the standards of the Society of Automotive Engineers (SAE), this makes the valves for SAE bases interchangeable.

These SAE Size 125, 250, and 500 valves are available as, 2-position, 5-ported 4-way solenoid pilot valves with either internal or external pilot supply.

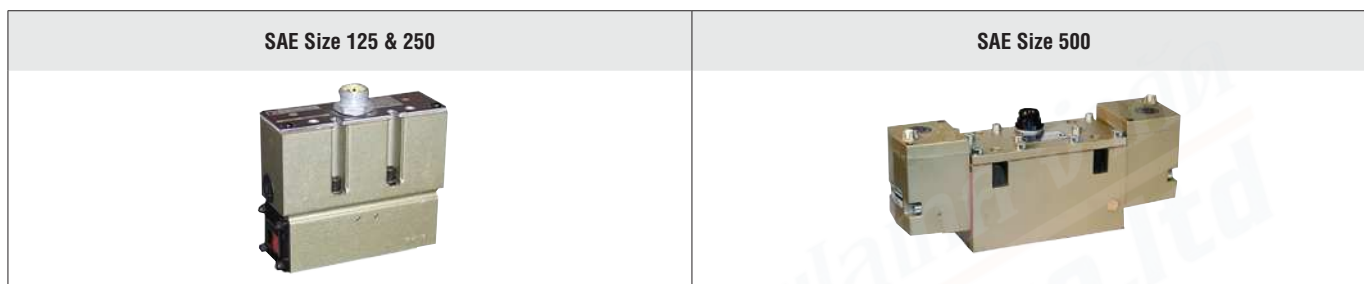

Illustration examples.

### VALVE FEATURES

<b>Poppet Design</b>	Highly tolerant of contaminated air and are self compensating for wear
<b>Mounting Options</b>	Individual sub-base or manifold base mounting
<b>Pilot Supply</b>	Internal or external
<b>Pilot Operation</b>	Provides high shifting force with low power consumption

SAE Size	Available Inlet Port Sizes					Functions		Actuation	Maximum Flow C <sub>v</sub>	Page
	1/4	3/8	1/2	3/4	1	5/2		Solenoid Control		
						Single	Double			
125	●	●				●	●	●	1.0	11 – 15
250		●	●	●		●	●	●	2.5	
500			●	●	●	●	●	●	4.2	
<b>Sub-Bases &amp; Manifold Bases</b>										16 – 20
<b>Accessories and Options</b>										21

## STANDARD SPECIFICATIONS

<b>GENERAL</b>	Function	5/2 Valve	
	Construction Design	Poppet	
	Actuation	Electrical – Solenoid Pilot Controlled	
	Mounting	Base	
	Connection	Threaded; NPT	
	Manual Override	Flush; rubber, non-locking	
	Solenoid Indicator Light	One per solenoid	
<b>OPERATING CONDITIONS</b>	Temperature	Ambient	40° to 120°F (4° to 50°C)
		Media	40° to 175°F (4° to 80°C)
	Flow Media	Filtered air	
	Operating Pressure	30 to 150 psig (2 to 10 bar)	
	Pilot Supply Pressure	Minimum 30 psig (2 bar)	
External Pilot Supply	Must be equal to or greater than inlet pressure		
<b>ELECTRICAL DATA FOR SOLENOID PILOT</b>	Solenoids	Rated for continuous duty	
	Operating Voltage (each solenoid)	24 volts DC 100-120 volts AC, 50/60 Hz 230-240 volts AC, 50/60 Hz	
	Power Consumption	SAE Size 125 & 250	24 V DC – 8 watts 100-130 V AC – 8 VA inrush, 6 VA holding 230-240 V AC – 8 VA inrush, 6 VA holding
		SAE Size 500	24 V DC – 14 watts 110-120 V AC – 87 VA inrush, 30 VA holding 230-240 V AC – 87 VA inrush, 30 VA holding
<b>CONSTRUCTION MATERIAL</b>	Valve Body	Cast Aluminum	
	Poppet	Rubber Coated Aluminum & Stainless Steel	
	Seals	Buna-N	

**IMPORTANT NOTE:** Please read carefully and thoroughly all of the CAUTIONS, WARNINGS on the inside back cover.

## PRODUCT CREDENTIALS

<p><b>CSA</b> Certificate of Compliance</p> 	<p><b>CE</b> Conformity Declaration</p> 	<p><b>EAC</b> Conformity Declaration</p> 	<p><b>CRN Certification</b></p> <p>Available for appropriately tested valves</p>
---	---	--	--

# Ordering Information

## 5/2 Single Solenoid Pilot Controlled Valves

### SINGLE SOLENOID PILOT CONTROLLED VALVES

### 5-Way 2-Position Valves

Wiring Type	Connector Type	SAE Size	Valve Model Number*		
			Voltage		
			24 V DC	120 V AC	230 V AC
Chrysler Stellantis Wired	mini-connector 5-pin	125	8476C3341W	8476C3341Z	8476C3341Y
		250	8476C4341W	8476C4341Z	8476C4341Y
		500	8476B6341W	8476B6341Z	8476B6341Y
	micro-connector 5-pin	125	8476C3321	8476C3311	–
		250	8476C4321	8476C4311	–
		500	8476B6321	8476B6311	–
Ford Wired	mini-connector 5-pin	125	8476C3331W	8476C3331Z	8476C3331Y
		250	8476C4331W	8476C4331Z	8476C4331Y
		500	8476B6331W	8476B6331Z	8476B6331Y
	micro-connector 4-pin	125	8476C3361	–	–
		250	8476C4361	–	–
		500	8476B6361	–	–
Hardwire		125	8476C3351W	8476C3351Z	8476C3351Y
		250	8476C4351W	8476C4351Z	8476C4351Y
		500	8476B6351W	8476B6351Z	8476B6351Y

For other voltages, consult ROSS.

\* Sub-bases and manifold bases ordered separately. Please see Sub-Bases and Manifolds pages.

Pressure Controlled Spool & Sleeve Valves for SAE available, consult ROSS.

SAE Size	Flow C <sub>v</sub>	Average Response Constants*			Weight lb (kg)	
		1-2	M	F		
				1-2		2-3
125	1.8	47	1.6	3.0	2.8 (1.3)	
250	5.5	60	0.6	0.8	5.2 (2.4)	
500	7.9	30	0.4	0.5	7.7 (3.5)	

**Valve Response Time** – Response Time (msec) = M + (F • V). This is the average time required to fill a volume V (cubic inches) to 90% of supply pressure or to exhaust it to 10% of supply pressure. M and F values are shown above.

#### Valve Schematic

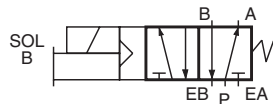

## 5/2 Single Solenoid Pilot Controlled Valves

### DIMENSIONS

Inches (mm)

SAE Size 125

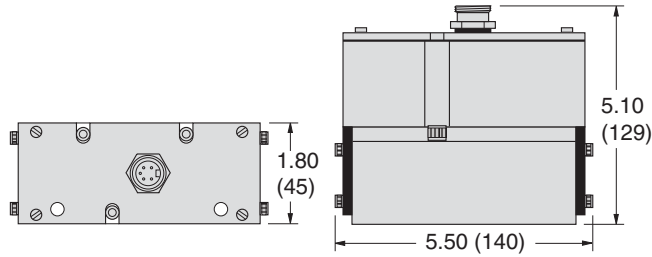

SAE Size 250

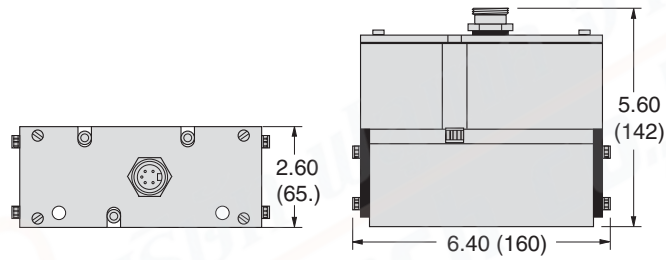

SAE Size 500

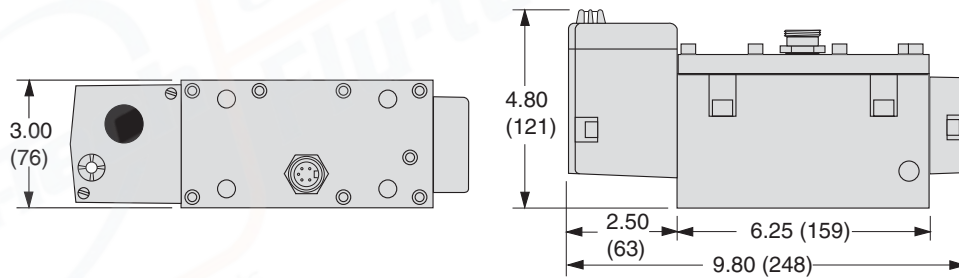

For additional information, and to assist you with piping and connectivity designs, our products are available in downloadable 2D drawings and 3D CAD models in a wide range of options including native formats. Please visit [www.rosscontrols.com](http://www.rosscontrols.com).

### Wiring Diagrams

5-pin mini-connector (all voltages)

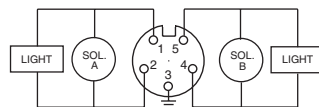

5-pin micro-connector (V DC)

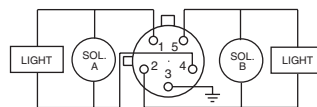

5-pin micro-connector (V AC)

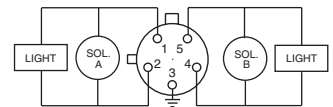

Chrysler Stellantis Wired

5-pin mini-connector (all voltages)

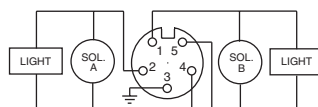

4-pin micro-connector (V DC)

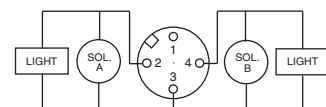

Ford Wired

# Ordering Information

## 5/2 Double Solenoid Pilot Controlled Valves

### DOUBLE SOLENOID PILOT CONTROLLED VALVES

### 5-Way 2-Position Valves

Wiring Type	Connector Type	SAE Size	Valve Model Number*		
			Voltage		
			24 V DC	120 V AC	230 V AC
Chrysler Stellantis Wired	mini-connector 5-pin	125	8476C3342W	8476C3342Z	8476C3342W
		250	8476C4342W	8476C4342Z	8476C4342Y
		500	8476B6342W	8476B6342Z	8476B6342Y
	micro-connector 5-pin	125	8476C3322	8476C3312	–
		250	8476C4322	8476C4312	–
		500	8476B6322	8476B6312	–
Ford Wired	mini-connector 5-pin	125	8476C3331W	8476C3331Z	8476C3331Y
		250	8476C4331W	8476C4331Z	8476C4331Y
		500	8476B6331W	8476B6331Z	8476B6331Y
	micro-connector 4-pin	125	8476C3362	–	–
		250	8476C4362	–	–
		500	8476B6362	–	–
Hardwire		125	8476C3352W	8476C3352Z	8476C3352Y
		250	8476C4352W	8476C4352Z	8476C4352Y
		500	8476B6352W	8476B6352Z	8476B6352Y

For other voltages, consult ROSS.

\* Sub-bases and manifold bases ordered separately. Please see Sub-Bases and Manifolds pages.

Pressure Controlled Spool & Sleeve Valves for SAE available, consult ROSS.

SAE Size	Flow C <sub>v</sub>	Average Response Constants*			Weight lb (kg)	
		1-2	M	F		
				1-2		2-3
125	1.8	16	1.7	2.4	3.3 (1.5)	
250	5.7	20	0.6	0.8	5.7 (2.6)	
500	7.6	16	0.2	0.5	8.9 (4.1)	

**Valve Response Time** – Response Time (msec) = M + (F • V). This is the average time required to fill a volume V (cubic inches) to 90% of supply pressure or to exhaust it to 10% of supply pressure. M and F values are shown above.

#### Valve Schematic

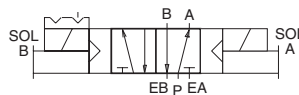

## 5/2 Double Solenoid Pilot Controlled Valves

### DIMENSIONS

Inches (mm)

SAE Size 125

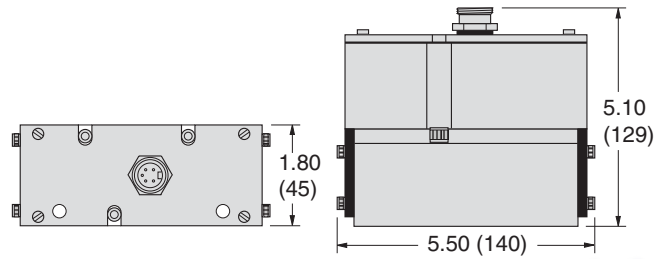

SAE Size 250

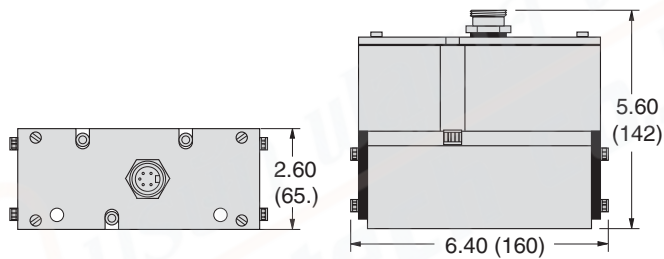

SAE Size 500

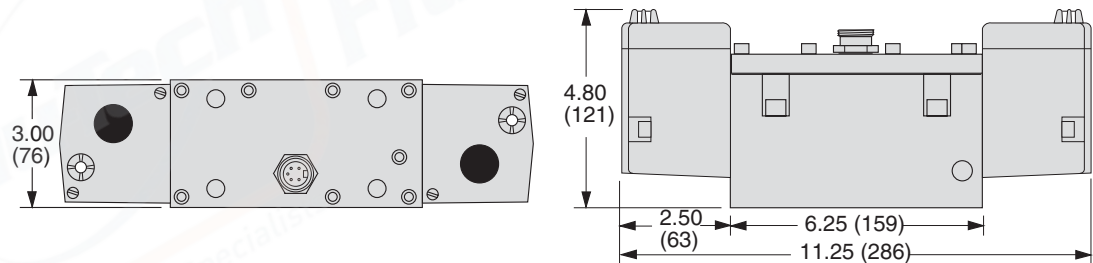

For additional information, and to assist you with piping and connectivity designs, our products are available in downloadable 2D drawings and 3D CAD models in a wide range of options including native formats. Please visit [www.rosscontrols.com](http://www.rosscontrols.com).

### Wiring Diagrams

Chrysler Stellantis Wired

5-pin mini-connector (all voltages)

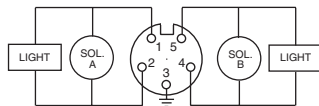

5-pin micro-connector (V DC)

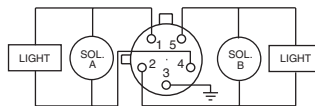

5-pin micro-connector (V AC)

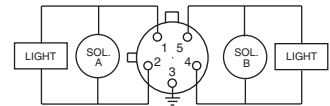

Ford Wired

5-pin mini-connector (all voltages)

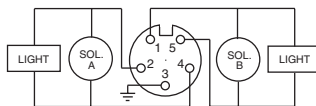

4-pin micro-connector (V DC)

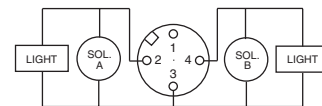

## Sub-Bases – Side Ported Ordering Information

SIDE PORTED SUB-BASES				
Size				Model Number*
SAE Size	Inlet (P)	Outlet (A, B)	Exhaust (EA, EB)	NPT Thread
125	1/4	1/8	1/4	577K91
	3/8	1/4	3/8	578K91
	3/8	3/8	3/8	579K91
250	3/8	1/4	3/8	539K91
	1/2	3/8	1/2	540K91
	1/2	1/2	1/2	541K91
	3/4	3/4	3/4	542K91
500	3/8	1/4	3/8	582K91
	1/2	3/8	1/2	728K91
	1/2	1/2	1/2	583K91
	3/4	3/4	3/4	584K91

\*For SAE threads, consult ROSS.



## DIMENSIONS

Inches (mm)

SAE Size 125

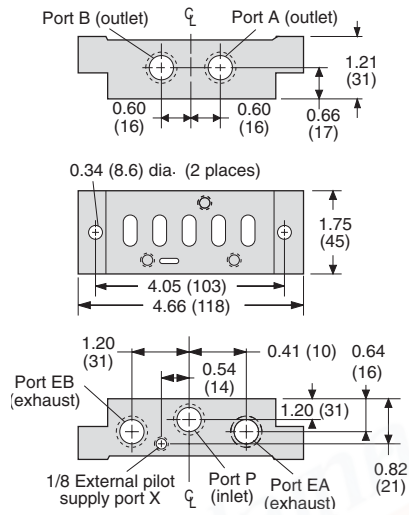

SAE Size 250

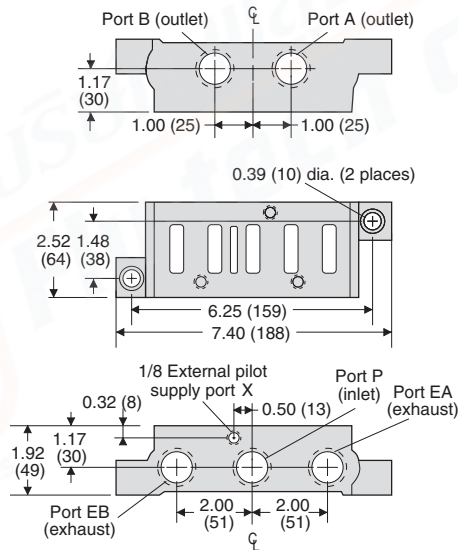

SAE Size 500

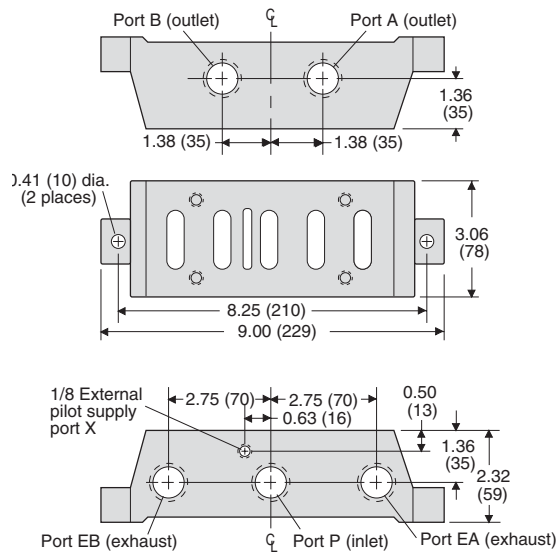

For additional information, and to assist you with piping and connectivity designs, our products are available in downloadable 2D drawings and 3D CAD models in a wide range of options including native formats. Please visit [www.rosscontrols.com](http://www.rosscontrols.com).

# Manifold Bases Ordering Information

MANIFOLD BASES				
Size				Model Number*
SAE	Inlet (P)	Outlet (A, B)	Exhaust (EA, EB)	NPT Thread
125	3/8	1/4	3/8	580K91
	3/8	3/8	3/8	581K91
250	1/2	1/2	1/2	553K91
	3/4	3/4	3/4	554K91
	3/4	3/4	3/4	555K91
500	3/4	1/2	3/4	585K91
	1	3/4	1	586K91
	1	1	1	587K91

\*For SAE threads, consult ROSS.

### Manifold Stations

Each manifold station is supplied with all necessary seals and hardware for assembly. End plates are not required with these manifolds. Each station has all ports threaded to accept piping.

# Manifold Bases Technical Data



## DIMENSIONS

Inches (mm)

### SAE Size 125

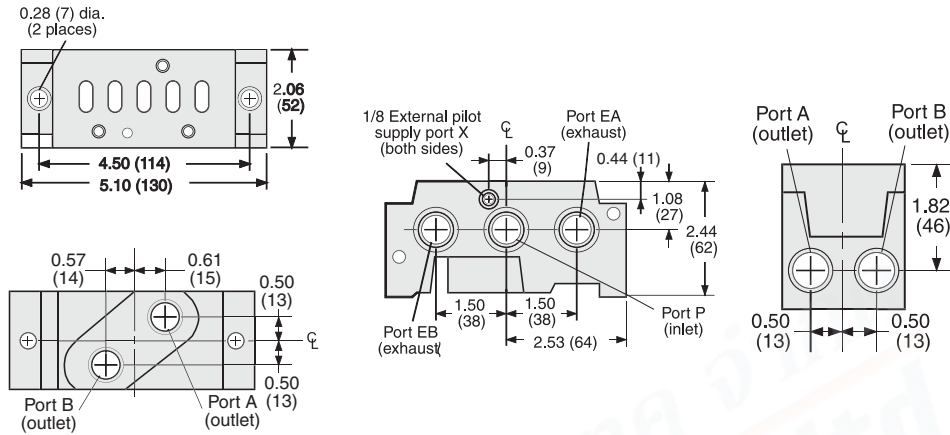

### SAE Size 250

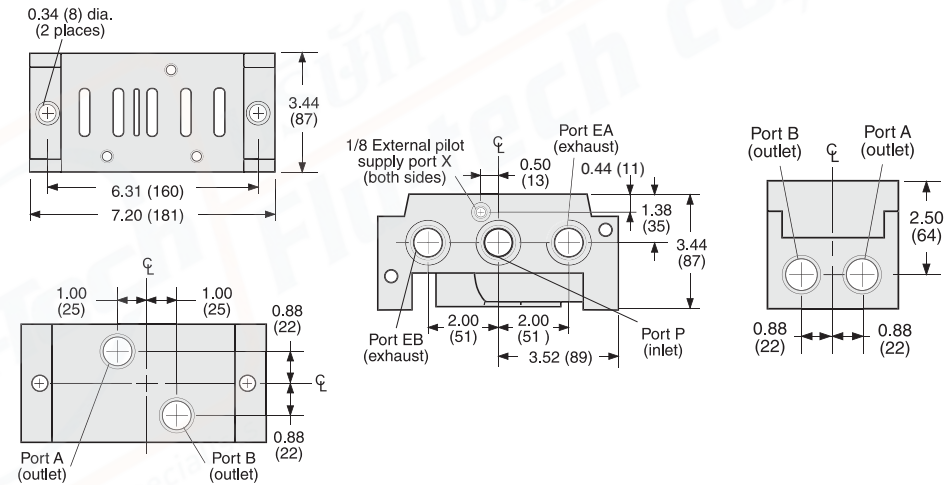

### SAE Size 500

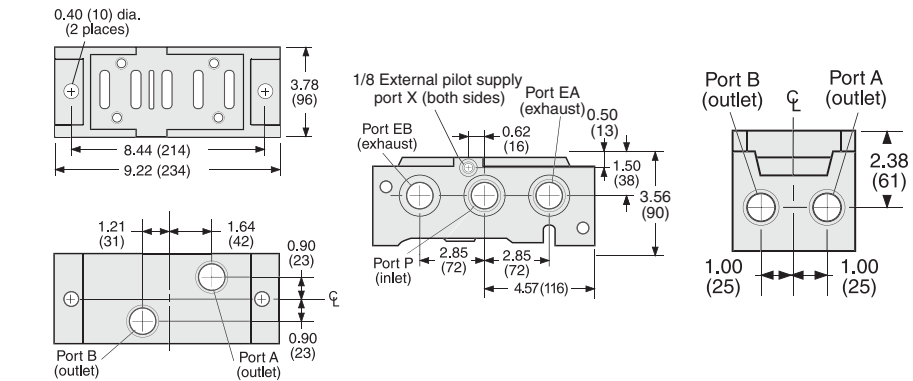

For additional information, and to assist you with piping and connectivity designs, our products are available in downloadable 2D drawings and 3D CAD models in a wide range of options including native formats. Please visit [www.rosscontrols.com](http://www.rosscontrols.com).

## Accessories & Options

### MANIFOLD PLATES

Blanking Plates	SAE Size	Model Number
	125	820K77
	250	821K77
	500	822K77

For manifold stations not occupied by a valve, blanking plates are available. These plates block the unused air passages.

### SOLENOID PILOT OPTIONS

Manual Override Kits for SAE Size 500 Valves	Flush Button		Extended Button		Extended Button with Palm	
	Locking Type	Kit Number	Locking Type	Kit Number	Locking Type	Kit Number
	Non-Locking	790K87	Non-Locking	791K87	Non-Locking	984H87
	Locking	792K87				

Flush flexible manual override buttons are standard on all SAE 500 solenoid pilot valves. Metal buttons as shown below can be installed in place of the standard flexible buttons. Both locking and non-locking metal buttons are available. Each button has spring-return action. The locking type button, however, can be kept in the actuated position by turning the slot in the top of the button with a screwdriver.

### SILENCERS

Silencers	Port Size	Thread Type	Model Number		Flow Avg. C <sub>v</sub>	Pressure Range psig (bar)
			R/Rp Thread	NPT Thread		
	1/4	Male	D5500A2003	5500A2003	2.1	0-290 (0-20) maximum
3/8	Male	D5500A3013	5500A3013	2.7		
		D5500A3003	5500A3003	4.3		
1/2	Male	D5500A4003	5500A4003	4.7		
3/4	Male	D5500A5013	5500A5013	5.1		
		D5500A5003	5500A5003	11.5		
1	Male	D5500A6003	5500A6003	14.6		

## INTERPOSED PRESSURE REGULATORS

SAE Size	Regulator Type	Model Number	Regulated Pressure Range psig (bar)
		Single	
125	Single	593K91	10 to 130 (1 to 9)
	Dual	873H91	
250	Single	595K91	
	Dual	816H91	

**Interposed Regulators**

A regulator is sandwiched between the valve and sub-base or manifold station and the valve is then bolted through the regulator to the sub-base or manifold station with the longer bolts provided.

Single pressure regulators supply the same regulated pressure at both outlet ports.

Dual pressure regulators allow the pressure at each outlet port to be set independently.

Use dual pressure regulators with 80 Series valves only. When using dual pressure regulators, the valve must be externally piloted. For external pilot supply conversion, see below.

Regulator-to-base gasket included.

**EXTERNAL PILOT SUPPLY CONVERSION**

ROSS SAE Solenoid pilot valves are designed to use an internal pilot supply. However, they are easily converted for use with an external pilot supply. To make this conversion, remove the pipe plug on the bottom of the valve. The plug is located between the center port and an adjacent port. Install this plug in the threaded port at the end of the center port. This blocks the internal pilot supply. Connect the external pilot supply line to port X in the base. Pressure in the external supply line must not be less than that specified in the valve's Standard Specifications.

DIMENSIONS		Inches (mm)
SAE Size 125	Single	
	Double	
SAE Size 250	Single	
	Double	

For additional information, and to assist you with piping and connectivity designs, our products are available in downloadable 2D drawings and 3D CAD models in a wide range of options including native formats. Please visit [www.rosscontrols.com](http://www.rosscontrols.com).