

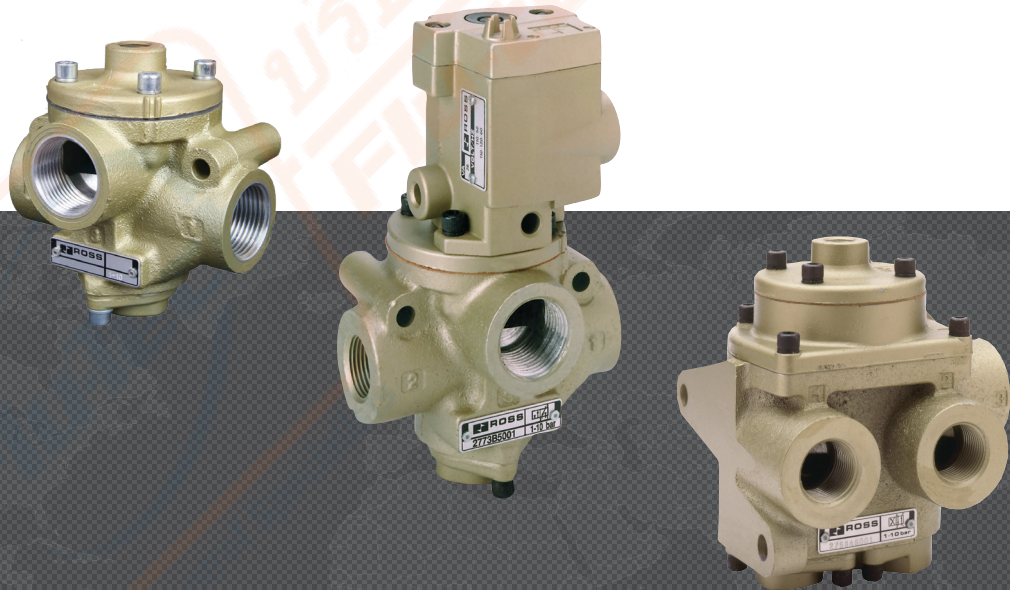

บริษัท ฟลูเทค จำกัด
Flu-tech co.,ltd
Authorized Distributor

DIRECTIONAL CONTROL HEADLINE VALVES 27 SERIES

PRODUCT CATALOG



บริษัท ฟลูเทค จำกัด
FLU - TECH CO., TD

845/3-4 หมู่ 3 ถ.เทพารักษ์ ต.เทพารักษ์ อ.เมือง จ.สมุทรปราการ 102070
845/3-4 Thepharak RD., T. Thepharak, A. Muang, Samutprakan 10270 THAILAND
Tel. 0 2384 6060, Fax 0 2384 5701, Email : sales@flutech.co.th, www.flutech.co.th

Headline Poppet Valves 27 Series

Product Overview

Directional Control Function

Directional control valves function is to control the direction of flow in the pneumatic circuit. Directional control valves are able to control the way the air passes. These valves can regulate the airflow being capable to stop fluid flow, allow fluid flow, and change the direction of fluid flow. These three functions usually operate in combination.

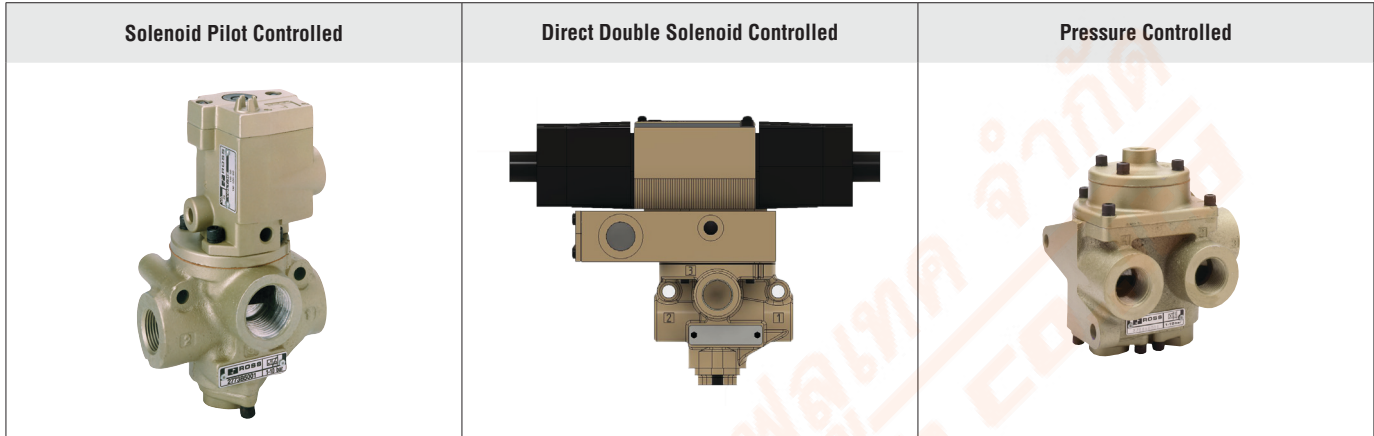

Illustration examples.

VALVE FEATURES

Poppet Design	Poppet construction for high dirt tolerance
Mounting Options	Can be mounted close to actuator, reducing length of pipe to be pressurized/exhausted on each cycle
Pilot Supply	Internal or external; easily field-convertible for use with an external pilot supply
High Velocity	Near zero leakage
Positive Sealing	No sliding action to prevent damage and wear
Reliability	Consistent response times over the life of the valve

Valve models for external pilot supply available, consult ROSS.

Explosion-Proof solenoid pilot valves available, see valves for Hazardous Locations.

For ATEX certified valves order placement, consult ROSS.



Actuation	Available Inlet Port Sizes									Functions			Maximum Flow C _v	Page
	1/4	3/8	1/2	3/4	1	1-1/4	1-1/2	2	2-1/2	2/2	3/2	4/2		
Solenoid Controlled	●	●	●	●	●	●	●	●	●	●	●		72	3 – 9
Direct Double Solenoid Controlled	●	●	●	●	●	●	●					●	34	10 – 13
Pressure Controlled	●	●	●	●	●	●	●			●	●	●	72	14 – 19
Accessories and Options														20

STANDARD SPECIFICATIONS

GENERAL	Function		2/2, 3/2, and 4/2 Valve	
	Construction Design		Poppet	
	Actuation		Electrical – Solenoid Pilot Controlled Pneumatic – Pressure Controlled	
	Mounting	Type	Inline	
		Orientation	Any, preferably vertical	
	Connection		Threaded; G, NPT	
Manual Override		Flush; rubber, non-locking		
OPERATING CONDITIONS	Temperature	Solenoid Pilot Controlled	Ambient	40° to 120°F (4° to 50°C)
			Media	40° to 175°F (4° to 80°C)
		Pressure Controlled	Ambient	40° to 175°F (4° to 80°C)
			Media	40° to 175°F (4° to 80°C)
	Flow Media		Filtered air	
	Operating Pressure	Body Size 3/8 & 1-1/2	15 to 150 psig (1 to 10 bar)	
		Body Size 2	30 to 150 psig (2.1 to 10 bar)	
External Pilot Supply		Must be equal to or greater than inlet pressure		
ELECTRICAL DATA FOR SOLENOID PILOT	Solenoids		Rated for continuous duty	
	Operating Voltage (each solenoid)		24 volts DC 110-120 volts AC, 50/60 Hz 230-240 volts AC, 60 Hz	
	Power Consumption		24 V DC – 14 watts 110-120 V AC – 87 VA inrush, 30 VA holding 230-240 V AC – 87 VA inrush, 30 VA holding	
CONSTRUCTION MATERIAL	Valve Body		Cast Aluminum	
	Poppet		Acetal and Stainless Steel	
	Seals		Buna-N	
SAFETY DATA	Safety Integrity Level (SIL)		Certified by TÜV Rheinland in accordance to IEC 61508 and IEC 61511 safety integrity level 2 (SIL 2) and EN ISO 13849-1, PL c (with application specific diagnosis) in singular application with HFT = 0 and SIL 3 and PL e in redundant application with HFT ≥ 1, for details see certificate.	

IMPORTANT NOTE: Please read carefully and thoroughly all of the CAUTIONS, WARNINGS on the inside back cover.

PRODUCT CREDENTIALS

SIL Safety Integrity Level 	CE Conformity Declaration 	EAC Conformity Declaration 	CSA Certificate of Compliance 	CRN Certification Available for appropriately tested valves
--	---	--	---	---

Ordering Information

2/2 Solenoid Pilot Controlled Valves

MODEL NUMBER CONFIGURATOR

2-Way 2-Position Valves

Thread: G **D** / NPT **Leave Blank**

Series: **27** / **7**

Actuation: Solenoid Controlled

Valve Function: 2/2 Normally Closed **1** / Normally Open **2**

Revision Level: **B**

Size:

Body	Port 1	Port 2	
3/8	1/4	1/4	2001
	3/8	3/8	3001
	1/2	1/2	4011
3/4	1/2	1/2	4001
	3/4	3/4	5001
	1	1	6011
1-1/4	1	1	6001
	1-1/4	1-1/4	7001
	1-1/2	1-1/2	8011
2	1-1/2	1-1/2	8001
	2	2	9001
	2-1/2	2-1/2	9011

Voltage*:

24 volts DC	W
110-120 volts AC, 50/60 Hz	Z
230-240 volts AC, 60 Hz	Y

* For other voltages consult ROSS.

Size			Flow C _v		Average Response Constants*			Weight lb (kg)
Body	Port 1	Port 2	Normally Closed	Normally Open	M	F		
			1-2	1-2		Normally Closed	Normally Open	
3/8	1/4	1/4	2.3	2.3	10	0.91	0.91	2.5 (1.2)
	3/8	3/8	3.8	3.3	10	0.70	0.76	
	1/2	1/2	4.0	3.5	10	0.64	0.72	
3/4	1/2	1/2	7.7	6.5	14	0.37	0.43	3.3 (1.5)
	3/4	3/4	9.0	7.3	14	0.34	0.39	
	1	1	9.0	7.9	14	0.34	0.37	
1-1/4	1	1	24	21	26	0.17	0.17	7.0 (3.2)
	1-1/4	1-1/4	29	20	26	0.15	0.19	
	1-1/2	1-1/2	29	21	26	0.15	0.18	
2	1-1/2	1-1/2	49	49	41	0.09	0.09	15.5 (6.9)
	2	2	57	57	41	0.07	0.07	
	2-1/2	2-1/2	64	72	41	0.07	0.06	

Valve Response Time – Response Time (msec) = M + (F • V). This is the average time required to fill a volume V (cubic inches) to 90% of supply pressure or to exhaust it to 10% of supply pressure. M and F values are shown above.

Valve Schematic

Normally Closed	Normally Open

2/2 Solenoid Pilot Controlled Valves

DIMENSIONS

Inches (mm)

Body Size 3/8

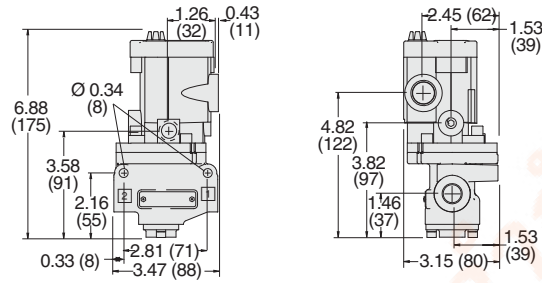

Body Size 3/4

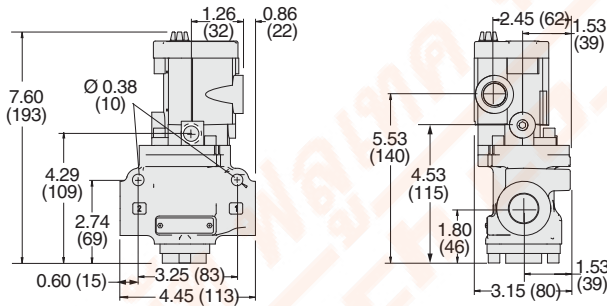

Body Size 1-1/4

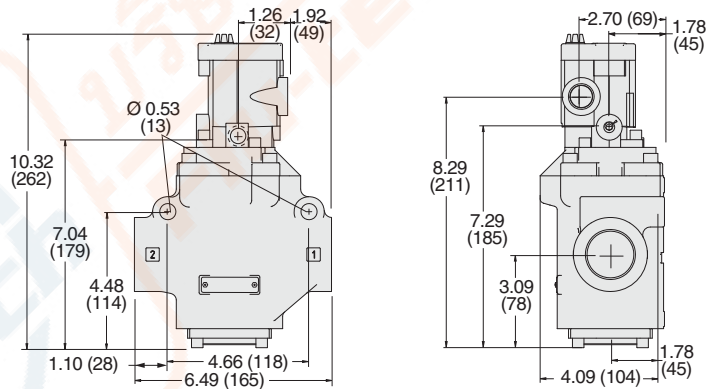

Body Size 2

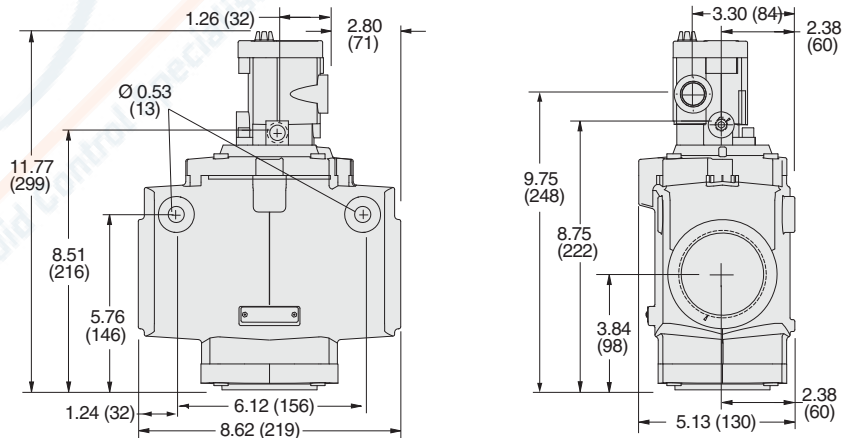

For additional information, and to assist you with piping and connectivity designs, our products are available in downloadable 2D drawings and 3D CAD models in a wide range of options including native formats. Please visit www.rosscontrols.com.

Ordering Information

3/2 Solenoid Pilot Controlled Valves

MODEL NUMBER CONFIGURATOR

3-Way 2-Position Valves

27
7
3
B
2001
W

Thread		Series		Revision Level		Voltage*	
G	D					24 volts DC	W
NPT	Leave Blank	Actuation				110-120 volts AC, 50/60 Hz	Z
		Solenoid Controlled				230-240 volts AC, 60 Hz	Y
						* For other voltages consult ROSS.	

Valve Function				
3/2	Normally Closed	3		
	Normally Open	4		

Size				
Body	Port 1	Port 2	Port 3	
3/8	1/4	1/4	1/2	2001
	3/8	3/8	1/2	3001
	1/2	1/2	1/2	4011
3/4	1/2	1/2	1	4001
	3/4	3/4	1	5001
	1	1	1	6011
1-1/4	1	1	1-1/2	6001
	1-1/4	1-1/4	1-1/2	7001
	1-1/2	1-1/2	1-1/2	8011
2	1-1/2	1-1/2	2-1/2	8001
	2	2	2-1/2	9001
	2-1/2	2-1/2	2-1/2	9011

Size				Flow Cv				Average Response Constants*				Weight lb (kg)	
Body	Port 1	Port 2	Port 3	Normally Closed		Normally Open		M	F				
				1-2	2-3	1-2	2-3		Normally Closed		Normally Open		
									1-2	2-3	1-2		2-3
3/8	1/4	1/4	1/2	2.5	3.1	2.3	2.7	10	0.90	0.80	0.99	0.88	2.5 (1.2)
	3/8	3/8	1/2	3.6	5.3	2.8	3.2	10	0.70	0.50	0.90	0.77	
	1/2	1/2	1/2	3.3	5.3	2.8	3.2	10	0.75	0.50	0.90	0.76	
3/4	1/2	1/2	1	6.3	9.2	6.3	8.0	11	0.43	0.27	0.46	0.60	3.3 (1.5)
	3/4	3/4	1	7.7	11	6.9	7.4	11	0.36	0.26	0.45	0.60	
	1	1	1	8.0	12	6.8	7.5	11	0.34	0.25	0.40	0.59	
1-1/4	1	1	1-1/2	23	34	17	24	28	0.17	0.14	0.20	0.17	7.0 (3.2)
	1-1/4	1-1/4	1-1/2	30	32	19	24	28	0.15	0.15	0.19	0.17	
	1-1/2	1-1/2	1-1/2	30	31	19	23	28	0.15	0.15	0.19	0.16	
2	1-1/2	1-1/2	2-1/2	68	70	57	59	76	0.05	0.04	0.07	0.04	16.5 (7.4)
	2	2	2-1/2	70	70	58	61	76	0.05	0.04	0.05	0.04	
	2-1/2	2-1/2	2-1/2	70	71	54	55	76	0.05	0.04	0.50	0.04	

Valve Response Time – Response Time (msec) = M + (F • V). This is the average time required to fill a volume V (cubic inches) to 90% of supply pressure or to exhaust it to 10% of supply pressure. M and F values are shown above.

Valve Schematic	
Normally Closed 	Normally Open

3/2 Solenoid Pilot Controlled Valves

DIMENSIONS

Inches (mm)

Body Size 3/8

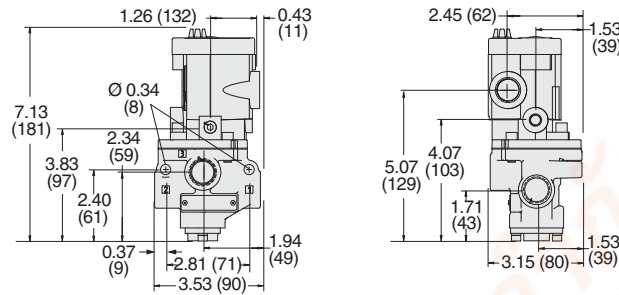

Body Size 3/4

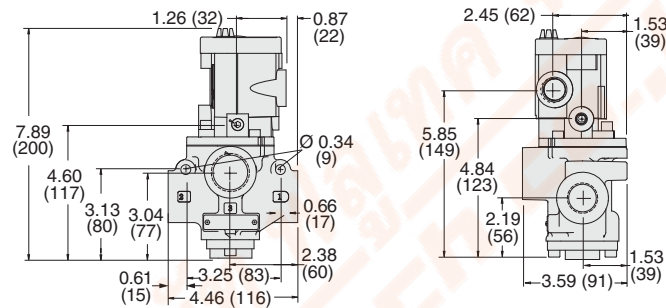

Body Size 1-1/4

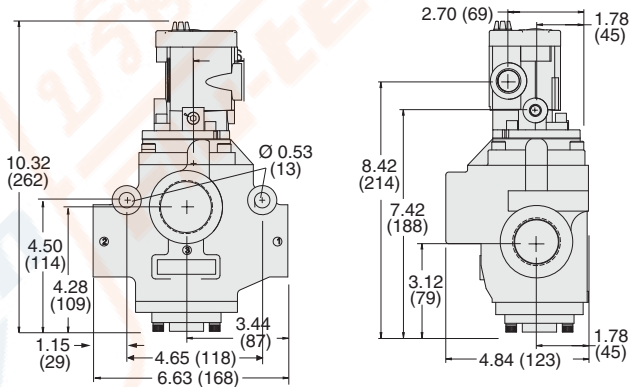

Body Size 2

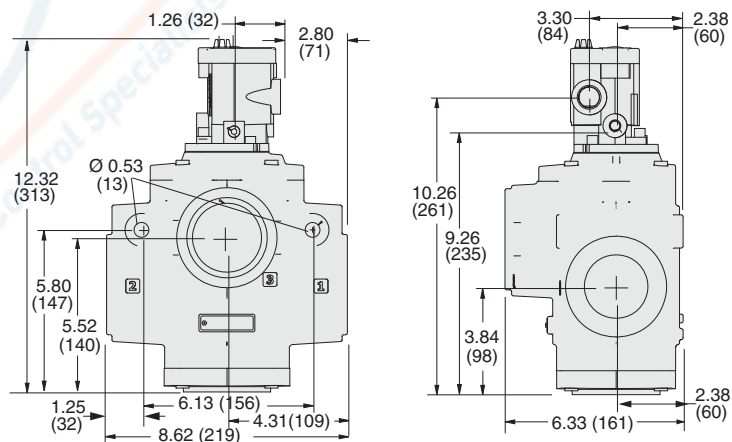

For additional information, and to assist you with piping and connectivity designs, our products are available in downloadable 2D drawings and 3D CAD models in a wide range of options including native formats. Please visit www.rosscontrols.com.

Ordering Information

4/2 Solenoid Pilot Controlled Valves

MODEL NUMBER CONFIGURATOR

4-Way 2-Position Valves

27
7
6
B
2001
W

Thread	Series	Revision Level	Voltage*
G D			24 volts DC W
NPT Leave Blank	Actuation		110-120 volts AC, 50/60 Hz Z
	Solenoid Controlled		230-240 volts AC, 60 Hz Y
	Valve Function		* For other voltages consult ROSS.
	4/2		

Size				
Body	Port 1	Port 2, 4	Port 3	
3/8	1/4	1/4	1/2	2001
	3/8	3/8	1/2	3001
	1/2	1/2	1/2	4011
3/4	1/2	1/2	1	4001
	3/4	3/4	1	5001
	1	1	1	6011
1-1/4	1	1	1-1/2	6001
	1-1/4	1-1/4	1-1/2	7001
	1-1/2	1-1/2	1-1/2	8011

Size				Flow Cv		Average Response Constants*			Weight lb (kg)
Body	Port 1	Port 2, 4	Port 3	1-2, 1-4	4-3, 2-3	M	F		
							1-2, 1-4	4-3, 2-3	
3/8	1/4	1/4	1/2	2.1	2.9	10	0.92	0.92	3.0 (1.4)
	3/8	3/8	1/2	2.9	4.2	10	0.90	0.90	
	1/2	1/2	1/2	3.1	4.3	10	0.89	0.73	
3/4	1/2	1/2	1	5.6	8.1	26	0.50	0.66	5.3 (2.4)
	3/4	3/4	1	7.0	9.3	26	0.36	0.55	
	1	1	1	7.8	10	26	0.35	0.50	
1-1/4	1	1	1-1/2	19	26	79	0.17	0.22	11.3 (5.1)
	1-1/4	1-1/4	1-1/2	21	27	79	0.16	0.18	
	1-1/2	1-1/2	1-1/2	22	27	79	0.15	0.15	

Valve Response Time – Response Time (msec) = M + (F • V). This is the average time required to fill a volume V (cubic inches) to 90% of supply pressure or to exhaust it to 10% of supply pressure. M and F values are shown above.

Valve Schematic

4/2 Solenoid Pilot Controlled Valves

DIMENSIONS – 4/2 VALVES

Inches (mm)

Body Size 3/8

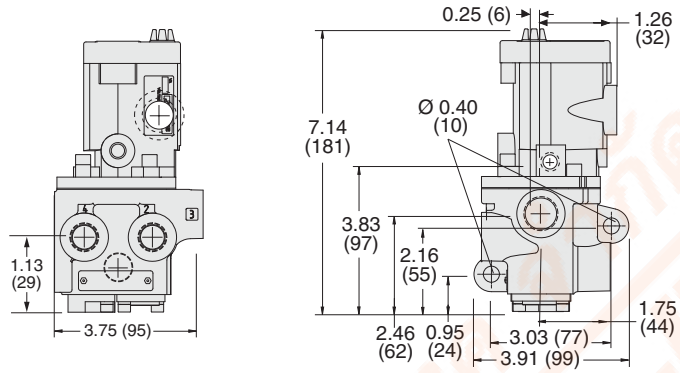

Body Size 3/4

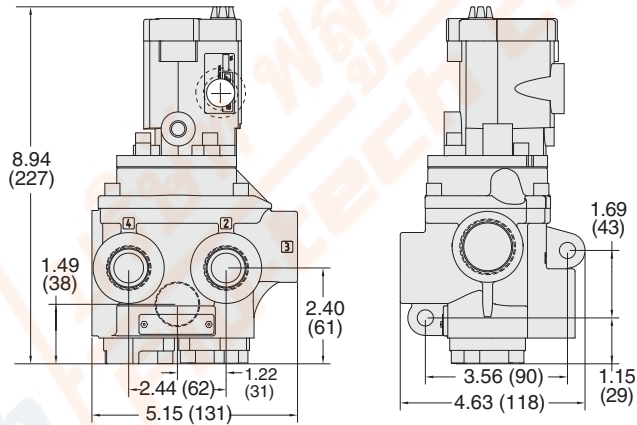

Body Size 1-1/4

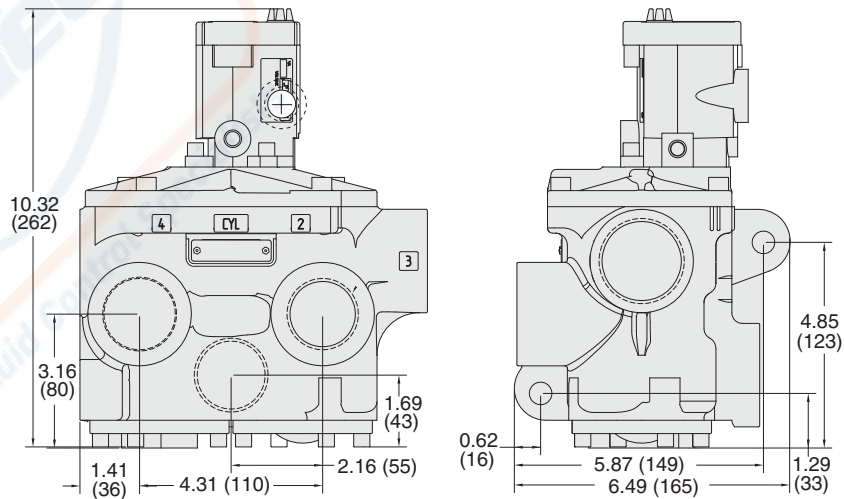

For additional information, and to assist you with piping and connectivity designs, our products are available in downloadable 2D drawings and 3D CAD models in a wide range of options including native formats. Please visit www.rosscontrols.com.

Ordering Information

3/2 Direct Double Solenoid Controlled Valves

MODEL NUMBER CONFIGURATOR

3-Way 2-Position Valves

27
7
3
B
2003
W

Thread	
G	D
NPT	Leave Blank

Series: 27, 7, 3

Actuation	
Direct Solenoid Controlled	

Valve Function	
3/2	Normally Closed 3
	Normally Open 4

Revision Level	
B	

Voltage*	
24 volts DC	W
110-120 volts AC, 50/60 Hz	Z
230-240 volts AC, 60 Hz	Y
* For other voltages consult ROSS.	

Body	Size			
	Port 1	Port 2	Port 3	
3/8	1/4	1/4	1/2	2003
	3/8	3/8	1/2	3003
	1/2	1/2	1/2	4013
3/4	1/2	1/2	1	4003
	3/4	3/4	1	5003
	1	1	1	6013
1-1/4	1	1	1-1/2	6003
	1-1/4	1-1/4	1-1/2	7003
	1-1/2	1-1/2	1-1/2	8013

Size				Flow Cv				Average Response Constants*				Weight lb (kg)	
Body	Port 1	Port 2	Port 3	Normally Closed		Normally Open		M	F				
				1-2	2-3	1-2	2-3		Normally Closed		Normally Open		
									1-2	2-3	1-2		2-3
3/8	1/4	1/4	1/2	2.5	3.1	2.3	2.7	10	0.90	0.80	0.99	0.88	2.5 (1.2)
	3/8	3/8	1/2	3.6	5.3	2.8	3.2	10	0.70	0.50	0.90	0.77	
	1/2	1/2	1/2	3.3	5.3	2.8	3.2	10	0.75	0.50	0.90	0.76	
3/4	1/2	1/2	1	6.3	9.2	6.3	8.0	11	0.43	0.27	0.46	0.60	3.3 (1.5)
	3/4	3/4	1	7.7	11	6.9	7.4	11	0.36	0.26	0.45	0.60	
	1	1	1	8.0	12	6.8	7.5	11	0.34	0.25	0.40	0.59	
1-1/4	1	1	1-1/2	23	34	17	24	28	0.17	0.14	0.20	0.17	7.0 (3.2)
	1-1/4	1-1/4	1-1/2	30	32	19	24	28	0.15	0.15	0.19	0.17	
	1-1/2	1-1/2	1-1/2	30	31	19	23	28	0.15	0.15	0.19	0.16	

Valve Response Time – Response Time (msec) = M + (F • V). This is the average time required to fill a volume V (cubic inches) to 90% of supply pressure or to exhaust it to 10% of supply pressure. M and F values are shown above.

Valve Schematic	
<p>Normally Closed</p>	
<p>Normally Open</p>	

3/2 Direct Double Solenoid Controlled Valves

DIMENSIONS – 3/2 VALVES

Inches (mm)

Body Size 3/8

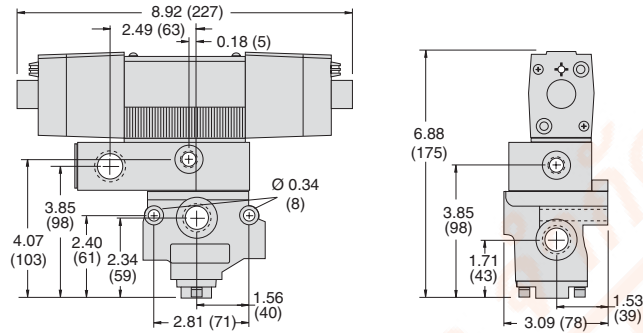

Body Size 3/4

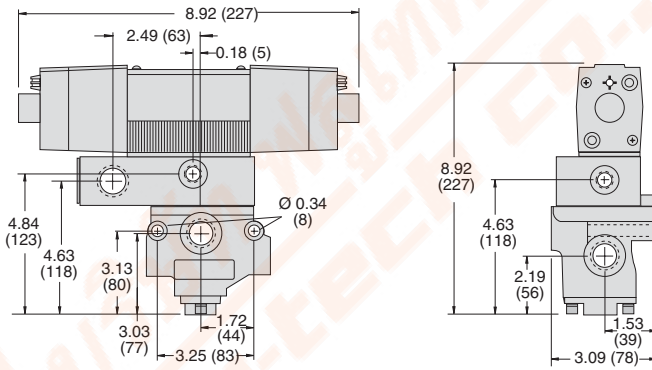

Body Size 1-1/4

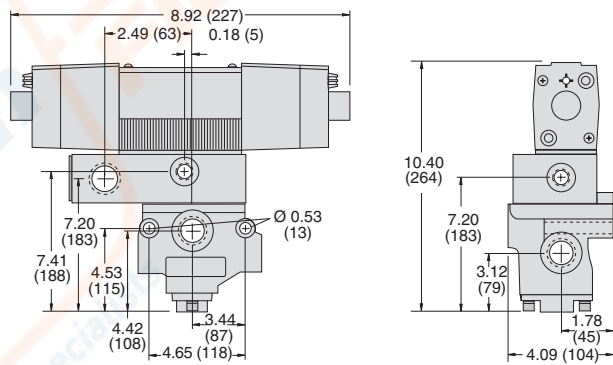

For additional information, and to assist you with piping and connectivity designs, our products are available in downloadable 2D drawings and 3D CAD models in a wide range of options including native formats. Please visit www.rosscontrols.com.

Ordering Information

4/2 Direct Double Solenoid Pilot Controlled Valves

MODEL NUMBER CONFIGURATOR

4-Way 2-Position Valves

27
7
6
B
2001
W

Thread	Series	Revision Level	Voltage*	
G D			24 volts DC W	
NPT Leave Blank	Actuation		110-120 volts AC, 50/60 Hz Z	
	Direct Solenoid Controlled		230-240 volts AC, 60 Hz Y	
	Valve Function		* For other voltages consult ROSS.	
	4/2			

Size				
Body	Port 1	Port 2, 4	Port 3	
3/8	1/4	1/4	1/2	2003
	3/8	3/8	1/2	3003
	1/2	1/2	1/2	4013
3/4	1/2	1/2	1	4003
	3/4	3/4	1	5003
	1	1	1	6013
1-1/4	1	1	1-1/2	6003
	1-1/4	1-1/4	1-1/2	7003
	1-1/2	1-1/2	1-1/2	8013

Size				Flow Cv		Average Response Constants*			Weight lb (kg)
Body	Port 1	Port 2, 4	Port 3	1-2, 1-4	4-3, 2-3	M	F		
							1-2, 1-4	4-3, 2-3	
3/8	1/4	1/4	1/2	2.1	2.9	10	0.92	0.92	0.92
	3/8	3/8	1/2	2.9	4.2	10	0.90	0.90	0.90
	1/2	1/2	1/2	3.1	4.3	10	0.89	0.73	0.73
3/4	1/2	1/2	1	5.6	8.1	26	0.50	0.66	0.66
	3/4	3/4	1	7.0	9.3	26	0.36	0.55	0.55
	1	1	1	7.8	10	26	0.35	0.50	0.50
1-1/4	1	1	1-1/2	19	26	79	0.17	0.22	0.22
	1-1/4	1-1/4	1-1/2	21	27	79	0.16	0.18	0.18
	1-1/2	1-1/2	1-1/2	22	27	79	0.15	0.15	0.15

Valve Response Time – Response Time (msec) = M + (F • V). This is the average time required to fill a volume V (cubic inches) to 90% of supply pressure or to exhaust it to 10% of supply pressure. M and F values are shown above.

Valve Schematic

4/2 Direct Double Solenoid Pilot Controlled Valves

DIMENSIONS

Inches (mm)

Body Size 3/8

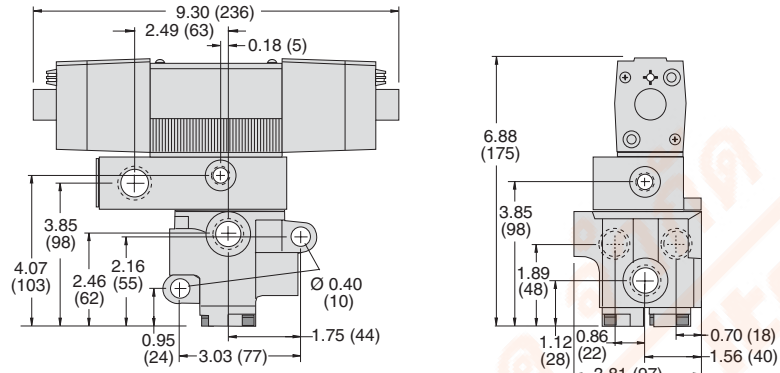

Body Size 3/4

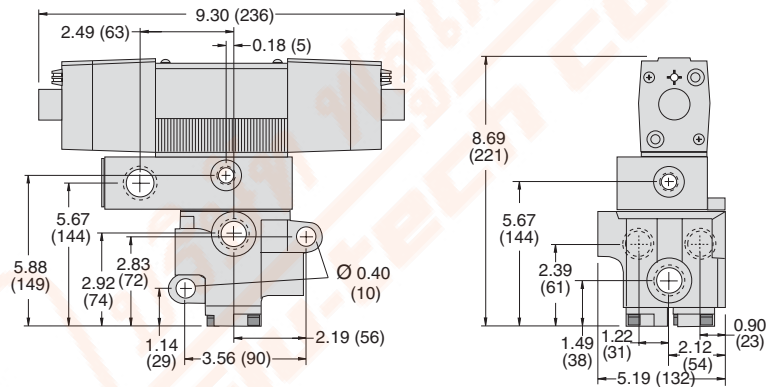

Body Size 1-1/4

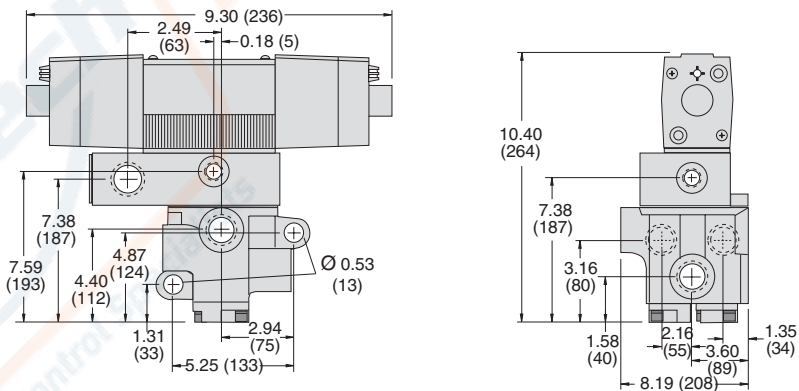

For additional information, and to assist you with piping and connectivity designs, our products are available in downloadable 2D drawings and 3D CAD models in a wide range of options including native formats. Please visit www.rosscontrols.com.

Ordering Information

2/2 Pressure Controlled Valves

MODEL NUMBER CONFIGURATOR

2-Way 2-Position Valves

27 5 1 A 2001

Thread	
G	D
NPT Leave Blank	

Series	
27 5	
Actuation	
Pressure Controlled	

Revision Level	
A	

Valve Function	
2/2	Normally Closed 1
	Normally Open 2

Size			
Body	Port 1	Port 2	
3/8	1/4	1/4	2001
	3/8	3/8	3001
	1/2	1/2	4011
3/4	1/2	1/2	4001
	3/4	3/4	5001
	1	1	6011
1-1/4	1	1	6001
	1-1/4	1-1/4	7001
	1-1/2	1-1/2	8011
2	1-1/2	1-1/2	8001
	2	2	9001
	2-1/2	2-1/2	9011

Size			Flow C _v		Average Response Constants*			Weight lb (kg)
Body	Port 1	Port 2	Normally Closed	Normally Open	M	F		
			1-2	1-2		Normally Closed	Normally Open	
3/8	1/4	1/4	2.3	2.3	10	0.91	0.91	2.5 (1.2)
	3/8	3/8	3.8	3.3	10	0.70	0.76	
	1/2	1/2	4.0	3.5	10	0.64	0.72	
3/4	1/2	1/2	7.7	6.5	14	0.37	0.43	3.3 (1.5)
	3/4	3/4	9.0	7.3	14	0.34	0.39	
	1	1	9.0	7.9	14	0.34	0.37	
1-1/4	1	1	24	21	26	0.17	0.17	7.0 (3.2)
	1-1/4	1-1/4	29	20	26	0.15	0.19	
	1-1/2	1-1/2	29	21	26	0.15	0.18	
2	1-1/2	1-1/2	49	49	41	0.09	0.09	15.5 (6.9)
	2	2	57	57	41	0.07	0.07	
	2-1/2	2-1/2	64	72	41	0.07	0.06	

Valve Response Time – Response Time (msec) = M + (F • V). This is the average time required to fill a volume V (cubic inches) to 90% of supply pressure or to exhaust it to 10% of supply pressure. M and F values are shown above.

Valve Schematic

Normally Closed	Normally Open

1/4" Signal Port

Port 2 (Outlet) Port 1 (Inlet)

2/2 Pressure Controlled Valves

DIMENSIONS

Inches (mm)

Body Size 3/8

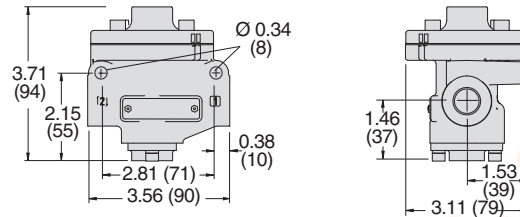

Body Size 3/4

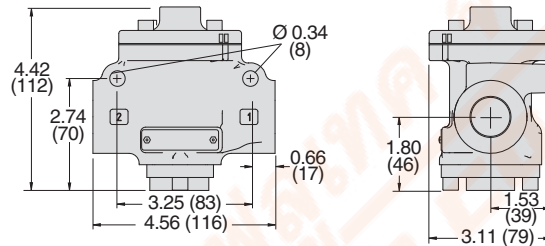

Body Size 1-1/4

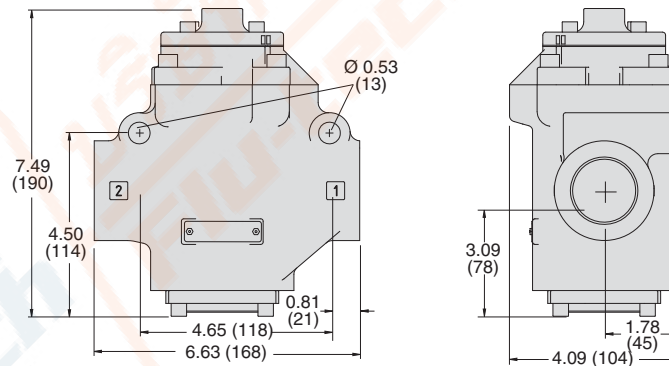

Body Size 2

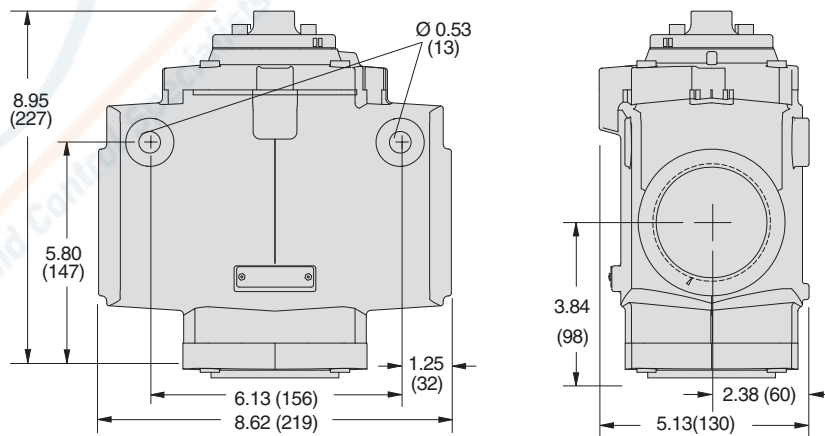

For additional information, and to assist you with piping and connectivity designs, our products are available in downloadable 2D drawings and 3D CAD models in a wide range of options including native formats. Please visit www.rosscontrols.com.

Ordering Information

3/2 Pressure Controlled Valves

MODEL NUMBER CONFIGURATOR

3-Way 2-Position Valves

27 5 3 A 2001

Thread	
G	D
NPT	Leave Blank

Series	
Actuation	
Pressure Controlled	

Valve Function	
3/2	Normally Closed 3
	Normally Open 4

Size				
Body	Port 1	Port 2	Port 3	
3/8	1/4	1/4	1/2	2001
	3/8	3/8	1/2	3001
	1/2	1/2	1/2	4011
3/4	1/2	1/2	1	4001
	3/4	3/4	1	5001
	1	1	1	6011
1-1/4	1	1	1-1/2	6001
	1-1/4	1-1/4	1-1/2	7001
	1-1/2	1-1/2	1-1/2	8011
2	1-1/2	1-1/2	2-1/2	8001
	2	2	2-1/2	9001
	2-1/2	2-1/2	2-1/2	9011

Size				Flow Cv				Average Response Constants*				Weight lb (kg)	
Body	Port 1	Port 2	Port 3	Normally Closed		Normally Open		M	F				
				1-2	2-3	1-2	2-3		Normally Closed		Normally Open		
									1-2	2-3	1-2		2-3
3/8	1/4	1/4	1/2	2.5	3.1	2.3	2.7	10	0.90	0.80	0.99	0.88	1.3 (0.6)
	3/8	3/8	1/2	3.6	5.3	2.8	3.2	10	0.70	0.50	0.90	0.77	
	1/2	1/2	1/2	3.3	5.3	2.8	3.2	10	0.75	0.50	0.90	0.76	
3/4	1/2	1/2	1	6.3	9.2	6.3	8.0	12	0.43	0.17	0.46	0.60	2.0 (0.9)
	3/4	3/4	1	7.7	11	6.9	7.4	12	0.36	0.26	0.45	0.60	
	1	1	1	8	12	6.8	7.5	12	0.34	0.25	0.40	0.59	
1-1/4	1	1	1-1/2	23	34	17	24	32	0.17	0.14	0.20	0.17	6.0 (2.7)
	1-1/4	1-1/4	1-1/2	30	32	19	24	32	0.15	0.15	0.19	0.17	
	1-1/2	1-1/2	1-1/2	30	31	19	23	32	0.15	0.15	0.19	0.16	
2	1-1/2	1-1/2	2-1/2	68	70	57	59	76	0.05	0.04	0.07	0.04	15.3 (6.9)
	2	2	2-1/2	70	70	58	61	76	0.05	0.04	0.05	0.04	
	2-1/2	2-1/2	2-1/2	70	71	54	55	76	0.05	0.04	0.05	0.04	

Valve Response Time – Response Time (msec) = M + (F • V). This is the average time required to fill a volume V (cubic inches) to 90% of supply pressure or to exhaust it to 10% of supply pressure. M and F values are shown above.

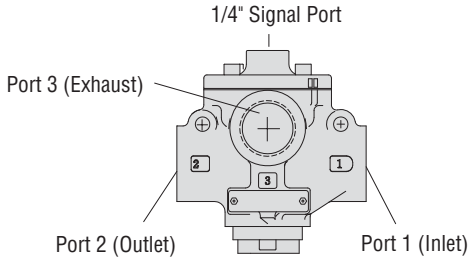
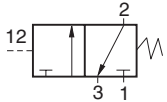
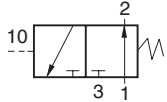
Valve Schematic		
Normally Closed	Normally Open	
		

3/2 Pressure Controlled Valves

DIMENSIONS

Inches (mm)

Body Size 3/8

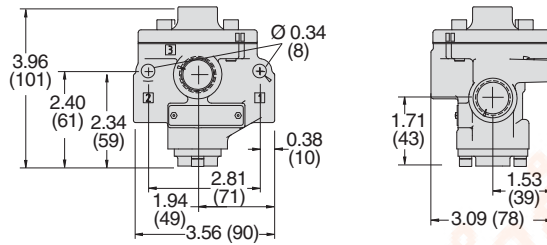

Body Size 3/4

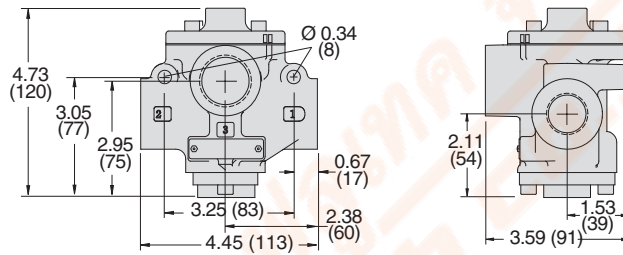

Body Size 1-1/4

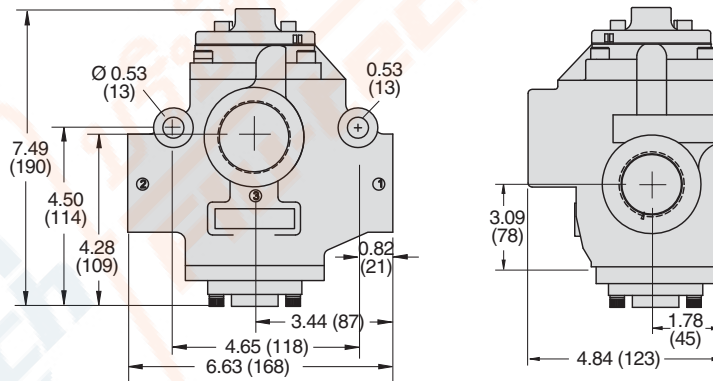

Body Size 2

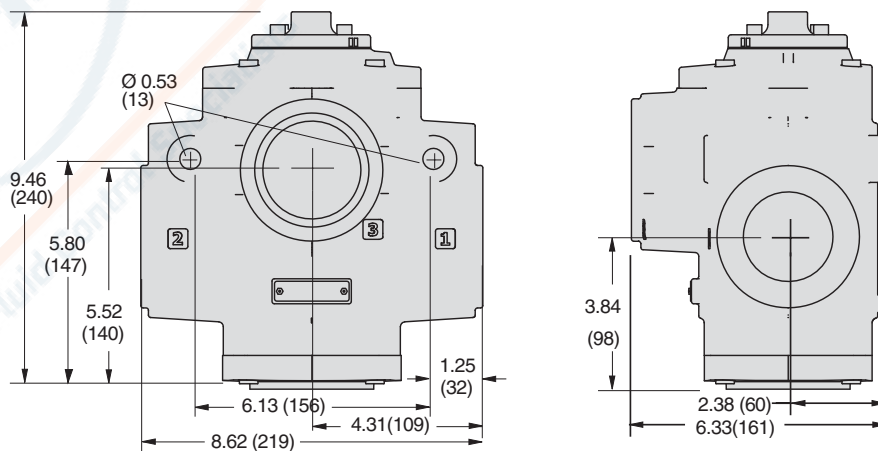

For additional information, and to assist you with piping and connectivity designs, our products are available in downloadable 2D drawings and 3D CAD models in a wide range of options including native formats. Please visit www.rosscontrols.com.

Ordering Information

4/2 Pressure Controlled Valves

MODEL NUMBER CONFIGURATOR

4-Way 2-Position Valves

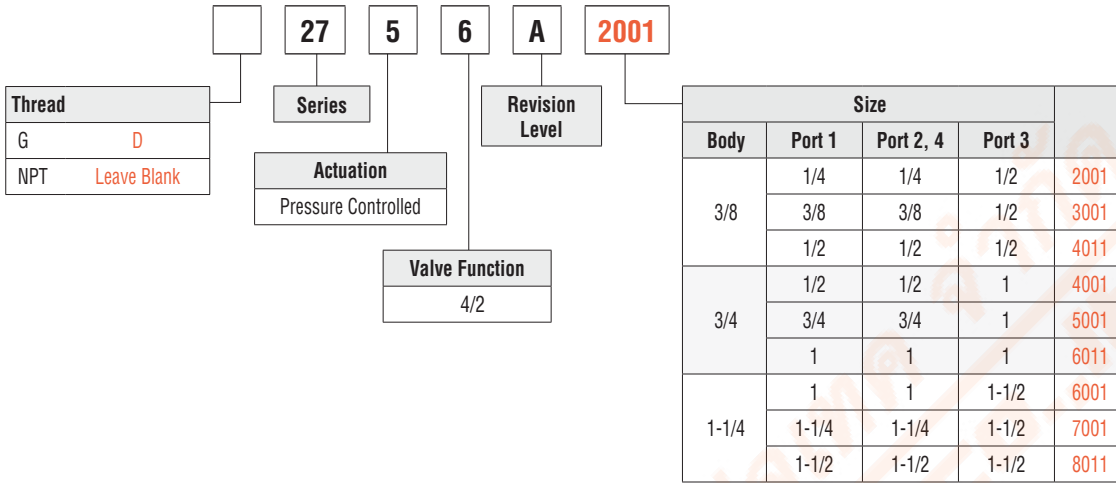

Body	Size			Flow Cv		Average Response Constants*			Weight lb (kg)
	Port 1	Port 2, 4	Port 3	1-2, 1-4	4-3, 2-3	M	F		
							1-2, 1-4	4-3, 2-3	
3/8	1/4	1/4	1/2	2.1	2.9	10	0.92	0.92	1.8 (0.8)
	3/8	3/8	1/2	2.9	4.2	10	0.90	0.90	
	1/2	1/2	1/2	3.1	4.3	10	0.89	0.73	
3/4	1/2	1/2	1	5.6	8.1	26	0.50	0.66	4.3 (1.9)
	3/4	3/4	1	7.0	9.3	26	0.36	0.55	
	1	1	1	7.8	10	26	0.35	0.50	
1-1/4	1	1	1-1/2	19	26	79	0.22	0.22	10.3 (4.6)
	1-1/4	1-1/4	1-1/2	21	27	79	0.18	0.18	
	1-1/2	1-1/2	1-1/2	22	27	79	0.15	0.15	

Valve Response Time – Response Time (msec) = M + (F • V). This is the average time required to fill a volume V (cubic inches) to 90% of supply pressure or to exhaust it to 10% of supply pressure. M and F values are shown above.

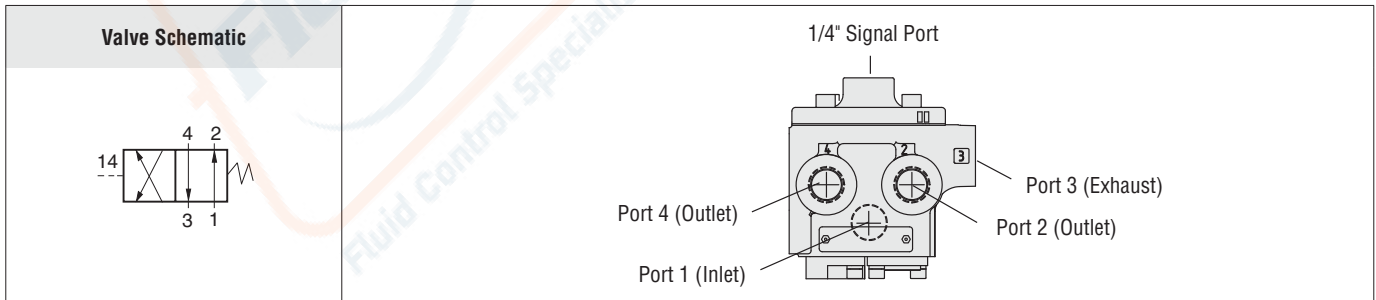

4/2 Pressure Controlled Valves

DIMENSIONS

Inches (mm)

Body Size 3/8

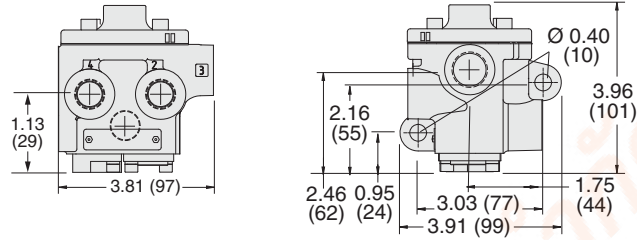

Body Size 3/4

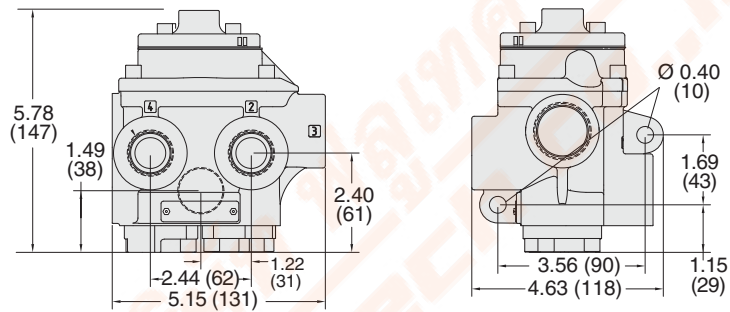

Body Size 1-1/4

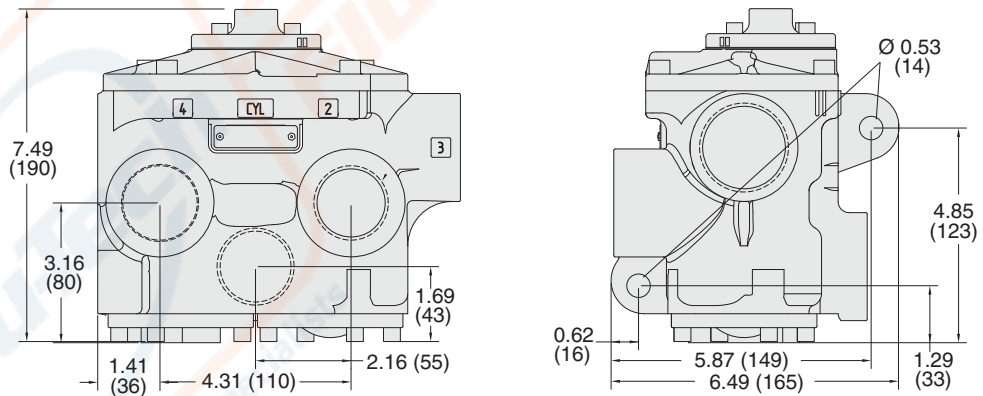

For additional information, and to assist you with piping and connectivity designs, our products are available in downloadable 2D drawings and 3D CAD models in a wide range of options including native formats. Please visit www.rosscontrols.com.

Accessories & Options

SILENCERS

Silencers	Port Size	Thread Type	Model Number		Flow Avg. C _v	Pressure Range psig (bar)
			R/Rp Thread	NPT Thread		
	1/2	Male	D5500A4003	5500A4003	4.7	
1	Male	D5500A6003	5500A6003	15	0-290 (0-20) maximum	
1-1/2	Female	D5500A8001	5500A8001	30		
2-1/2	Female	D5500A9002	5500A9002	104		

SOLENOID PILOT OPTIONS

Indicator Light Kits	Kit Number		
	24 V DC	110-120 V AC, 50-60 Hz	230 V AC, 50-60 Hz
	862K87-W	862K87-Z	862K87-Y

To visually verify valve operation, indicator light kits are available for single solenoid models. Indicator lights are standard on double solenoid valves. The indicator light is illuminated when the solenoid is energized.

Manual Override Kits	Flush Button		Extended Button		Extended Button with Palm	
	Locking Type	Kit Number	Locking Type	Kit Number	Locking Type	Kit Number
	Non-Locking	790K87	Non-Locking	791K87	Non-Locking	984H87
	Locking	792K87				

Flush flexible manual overrides are standard on single solenoid models. Double solenoid models have flush metal-button overrides. Both types are non-locking.

Each of the buttons in the override kits is made of metal and is spring-returned. The locking type button, however, can be kept in the actuated position by turning the slot in the top of the button with a screwdriver.