

High-Flow VANGUARD Externally Piloted Regulators

R200 Models Port Sizes: 1-1/2, 2

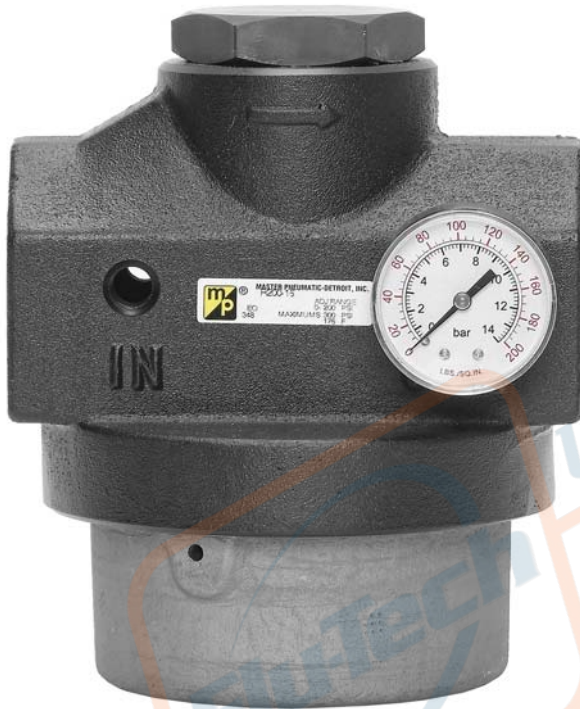

Model Shown: R200-12G

- ◆ Inline mounting.
- ◆ Piston-type design.
- ◆ Self-relieving.
- ◆ Pressure gauge.
- ◆ NPTF port threads; optional BSPP threads.

Note: Pilot (control) regulators (order separately).

- ◆ General purpose applications order R56M-2, R60-2, R67-2, R100-2, or R380-3
- ◆ Precision applications order IR100-2, R57M-2, IR380-3 or ER valve

SPECIFICATIONS

Ambient/Media Temperature:

40° to 175°F (4° to 79°C).

Body and Dome: Aluminum.

Fluid Media: Compressed air.

Inlet Pressure: 300 psig (21 bar) maximum.

Outlet Pressure: 0 to 200 psig (0 to 14 bar).

NOTE: Outlet pressure depends on the selection of the control regulator.

Pilot Ports: 1/4 NPTF.

Pressure Gauge: 0 to 200 psig (14 bar); 1/4 NPT gauge ports front and rear.

Seals: Nitrile; optional Viton seals.

Valve: Brass.

Valve Cap: Aluminum.

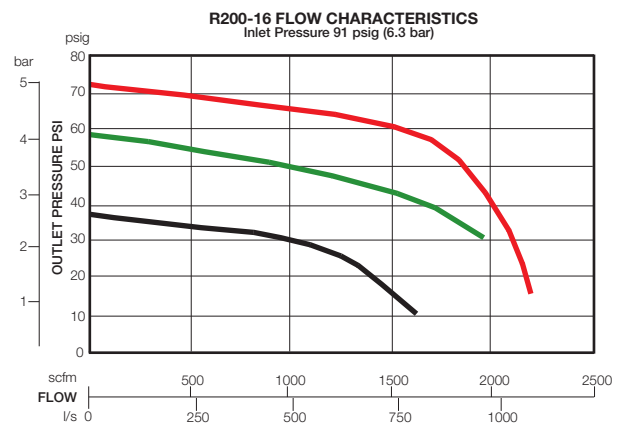

บริษัท ฟลูเทค จำกัด
FLU-TECH CO.,LTD

845/3-4 หมู่ 3 ถ.เทพารักษ์ ต.เทพารักษ์ อ.เมือง จ.สมุทรปราการ 10270

845/3-4 Thepharak RD., T.Thepharak, A.Muang, Samutprakarn 10270 THAILAND
Tel. 0 2384 6060, Fax 0 2384 5701, Email : sales@flutech.co.th, www.flutech.co.th

DIMENSIONS inches (mm)

A	B	C	Depth †	Weight †
				lb (kg)
6.4 (162)	5.0 (127)	3.0 (76)	5.8 (147)	8.94 (4.06)

† Less gauge.

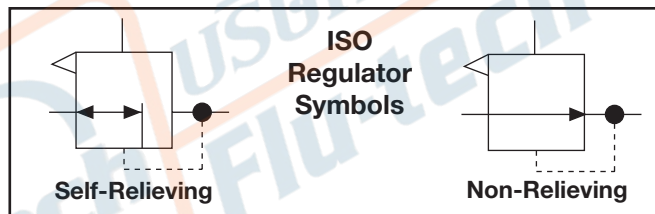
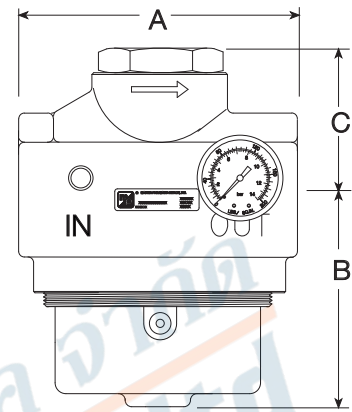

ORDERING INFORMATION

Change the letters in the sample model number below to specify the regulator you want.

NOTE: Order a control regulator such as R55M, R56M, R57M, R100, R380, IR100, or IR180 separately.

R20 0 - 12 Y G W

REGULATOR TYPE

Standard Regulator 0
 Standard Regulator with 2
 internal bias spring and gauge
 port plugged.

PORT SIZE

1-1/2 NPTF 12
 2 NPTF 16

OPTIONS (More than one option can be chosen)

None Leave Blank
 Non-relieving A
 Constant bleed Q
**Option '0' must be chosen
 under REGULATOR TYPE.**
 Viton seals V

PORT TYPE

NPTF threads Leave Blank
 BSPP threads W

OPTION

None Leave Blank
 0-200 PSI Gauge G



บริษัท ฟลูเทค จำกัด
FLU-TECH CO.,LTD

845/3-4 หมู่ 3 ถ.เทพารักษ์ ต.เทพารักษ์ อ.เมือง จ.สมุทรปราการ 10270

845/3-4 Thepharak RD., T.Thepharak, A.Muang, Samutprakarn 10270 THAILAND

Tel. 0 2384 6060, Fax 0 2384 5701, Email : sales@flutech.co.th, www.flutech.co.th