

Full-Size VANGUARD Modular Externally Piloted Regulators

PR100 Models Port Sizes: 1/4, 3/8, 1/2, 3/4



Model Shown: PR100-6G

- ◆ Modular or inline mounting.
- ◆ Self-relieving diaphragm design.
- ◆ Pressure gauge.
- ◆ NPTF port threads; optional BSPP threads.

Note: Pilot (control) regulators (order separately).

- ◆ General purpose applications order R56M-2, R60-2, R67-2, R100-2, or R380-3
- ◆ Precision applications order IR100-2, R57M-2, IR380-3 or ER valve

SPECIFICATIONS

Ambient/Media Temperature:

40° to 175°F (4° to 79°C).

Body: Zinc.

Dome: Zinc.

Fluid Media: Compressed air.

Inlet Pressure: 300 psig (21 bar) maximum.

Outlet Pressure: Adjustable 0 – 200 psig (0 – 14 bar).

Pilot Ports: 1/4 NPTF

Pressure Gauge: 0 to 200 psig (14 bar); 1/4 NPT gauge ports front and rear.

Seals: Nitrile.

Valve: Brass.

Valve Cap: Nylon.

FLOW CHARTS

Inlet Pressure: 100 psig (7 bar)

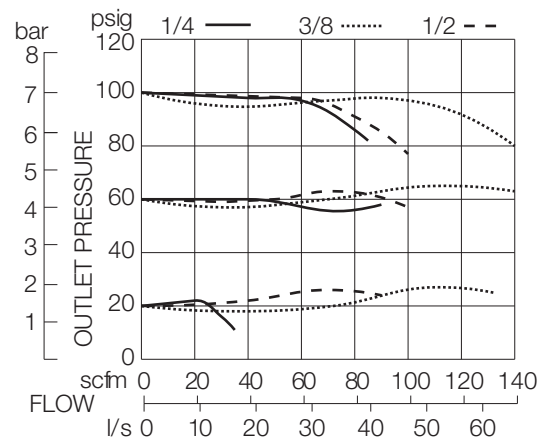

บริษัท ฟลูเทค จำกัด
FLU-TECH CO.,LTD

845/3-4 หมู่ 3 ถ.เทพารักษ์ ต.เทพารักษ์ อ.เมือง จ.สมุทรปราการ 10270

845/3-4 Thepharak RD., T.Thepharak, A.Muang, Samutprakarn 10270 THAILAND

Tel. 0 2384 6060, Fax 0 2384 5701, Email : sales@flutech.co.th, www.flutech.co.th

DIMENSIONS inches (mm)

| A | B | C | Depth † | Weight † lb (kg) |
|-------------|-------------|-------------|-------------|---------------------|
| 3.5 (89) | 2.4 (62) | 1.3 (33) | 2.8 (71) | 2.06 (0.92) |

† Less gauge.

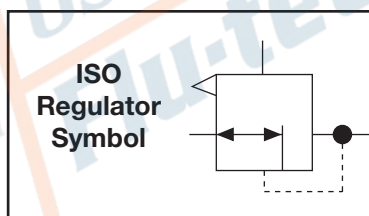
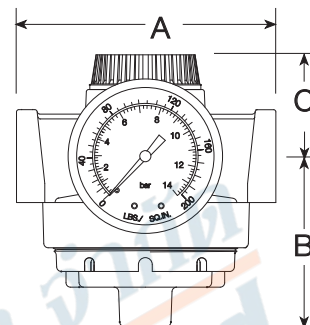

ORDERING INFORMATION

Change the letters in the sample model number below to specify the regulator you want.

NOTE: Order a pilot operator such as **R55-2**, **R56-2**, or **IR100-2** separately.

PR100 - 2 Y G W

PORT SIZE

| | |
|---------------|---|
| 1/4 NPTF..... | 2 |
| 3/8 NPTF..... | 3 |
| 1/2 NPTF..... | 4 |
| 3/4 NPTF..... | 6 |

PORT TYPE

| | |
|--------------------|-------------|
| NPTF threads | Leave Blank |
| BSP threads | W |

OPTION

| | |
|-----------------------|-------------|
| None | Leave Blank |
| 0-200 PSI Gauge | G |

OPTION

| | |
|---------------------|-------------|
| None | Leave Blank |
| Non-relieving | A |

MOUNTING BRACKETS

See page 356.



บริษัท ฟลูเทค จำกัด
FLU-TECH CO.,LTD

845/3-4 หมู่ 3 ถ.เทพารักษ์ ต.เทพารักษ์ อ.เมือง จ.สมุทรปราการ 10270

845/3-4 Thepharak RD., T.Thepharak, A.Muang, Samutprakarn 10270 THAILAND

Tel. 0 2384 6060, Fax 0 2384 5701, Email : sales@flutech.co.th, www.flutech.co.th