

# PRESSURE REGULATORS

Master Pneumatic regulators are made in a wide range of sizes to suit nearly all industrial requirements for pneumatic pressure regulation. Good pressure regulation is essential to the efficient use of pneumatic equipment. A compressor may supply air at 150 psig, but most of the equipment will operate best at lower pressures. A cylinder, for example, may develop sufficient force for its purpose with 50-psig air. Remember that compressed air is costly, so using higher air pressure than necessary is wasteful, and may also shorten the life of the cylinder. A general purpose pressure regulator is the answer for greater economy and efficiency.



Regulators are of two basic designs. Piston design provides highest air flow; diaphragm design provides high sensitivity and quick response. All regulators are self-relieving, but a non-relieving option is available. A pressure gauge is standard, and gauge ports are at the front and the rear of each unit.

In addition there are precision regulators in all port sizes for applications demanding extra precision in the regulation of air pressure, plus regulators for remote, external piloting.

## MODULAR or INLINE MOUNTING

**SENTRY, GUARDSMAN, SERIES 350, SERIES 380,** and **Full-Size VANGUARD** regulators are of modular design. Regulators are connected to filters or lubricators by special modular connectors which seal the faces between units. They may also be inline mounted with pipe nipples. **MINIATURE** and **High-Capacity VANGUARD** regulators are inline mounted only.

## SENTRY REGULATORS

Port sizes 1/8 and 1/4 or fittings for tubing up to 10 mm. Modular units have durable plastic, corrosion-resistant bodies. A non-relieving version can be used with water, oil, and many other liquids.

## GUIDE to REGULATORS and SERVO VALVES

REGULATOR SERIES	MODULAR	PORTS	PAGES
<b>SENTRY †</b>			
General Purpose <b>R10M, R11M</b> models	yes	1/8, 1/4	134-135
Water Pressure <b>R13M, R14M</b> models	yes	1/8, 1/4	196-197
External piloted <b>PR11M</b> models	yes	1/8, 1/4	166-167
<b>MINIATURE</b>			
General Purpose <b>R55M, R56M</b> models	no	1/8, 1/4	136-137
Stainless Steel <b>R56S</b> models	no	1/4	138-139
Precision <b>R57M</b> models	no	1/8, 1/4	158-159
Externally Piloted <b>PR56M</b> models	no	1/8, 1/4	168-169
Water Pressure <b>R53MB, R54MB</b> models	no	1/8, 1/4	198-209
Relief Valves <b>RV56</b> models	no	1/8, 1/4	164-201
CO <sub>2</sub> Miniature relief valve <b>CX</b> models	no	1/8, 1/4	202-203
CO <sub>2</sub> Miniature <b>CX</b> models	no	1/8, 1/4	140-141
High pressure model	no	1/8, 1/4, 3/8	146-147
<b>GUARDSMAN</b>			
General Purpose <b>R60</b> models	yes	1/4, 3/8, 1/2	142-143
<b>GUARDSMAN II</b>			
General Purpose <b>R75</b> models	yes	1/4, 3/8, 1/2	144-145
<b>350 SERIES</b>			
General Purpose <b>R350</b> models	yes	1/4, 3/8, 1/2	148-149
<b>Full-Size VANGUARD</b>			
General Purpose <b>R100</b> models	yes	1/4, 3/8, 1/2, 3/4	150-151
Precision <b>IR100</b> models	yes	1/4, 3/8, 1/2, 3/4	162-163
External Pilot <b>PR100</b> models	yes	1/4, 3/8, 1/2, 3/4	174-175
High relief externally pilot <b>HPR100</b>	no	1/4, 3/8, 1/2, 3/4	178-179
External relief pilot <b>PRH100</b> models	yes	1/4, 3/8, 1/2, 3/4	176-177
<b>Full-Size SERIES 380</b>			
General Purpose <b>R380</b> models	yes	3/8, 1/2, 3/4	152-153
Precision <b>IR380</b> models	yes	3/8, 1/2, 3/4	160-161
External pilot <b>PR380</b> models	yes	3/8, 1/2, 3/4	170-171
External relief pilot <b>PRH380</b> models	no	3/8, 1/2, 3/4	172-173
<b>High-Flow VANGUARD</b>			
General Purpose <b>R180, M</b> models	no	3/4, 1, 1-1/4, 1-1/2	154-157
Precision <b>IR180M</b> models	no	3/4, 1, 1-1/4, 1-1/2	164-165
External Pilot <b>PR180M</b> models	no	3/4, 1, 1-1/4, 1-1/2, 2	180-181
External Pilot <b>R200</b> models	no	1-1/2, 2	186-187
External pilot <b>PR300</b> models	no	3	194-195
High-relief externally pilot <b>HPR180</b>	no	3/4, 1, 1-1/4	184-185
External relief pilot <b>PRH180m</b> models	no	3/4, 1, 1-1/4, 1-1/2	182-183
Electro-Pneumatic Servo Valves	no		204-206

† Also available with quick-connect tube fittings up to 10 mm.



**บริษัท ฟลูเทค จำกัด**  
**FLU-TECH CO., LTD**

845/3-4 หมู่ 3 ถ.เทพารักษ์ ต.เทพารักษ์ อ.เมือง จ.สมุทรปราการ 10270

845/3-4 Thepharak RD., T.Thepharak, A.Muang, Samutprakarn 10270 THAILAND

Tel. 0 2384 6060, Fax 0 2384 5701, Email : sales@flutech.co.th, www.flutech.co.th

## MINIATURE REGULATORS

Port sizes 1/8, 1/4. Aluminum-bodied units for inline mounting. Same performance characteristics as the **SENTRY** models. Brass or stainless steel bodies, and water pressure models are also available.

**PRECISION MINIATURE** regulators are available to provide outstanding pressure control at relatively low cost. A large diaphragm area gives high sensitivity, and a small valve seat gives greater precision and little variation in outlet pressure from fluctuations in supply pressure. With an inlet pressure of 100 psig (7 bar), repeatability is within 1/4 psig. Regulated pressure range is 0–60 psig (0–4.1 bar). Optional springs allow other pressure ranges.

## GUARDSMAN REGULATORS

Port sizes 1/4, 3/8, 1/2. Modular units in a balanced-valve, piston design with very quick response for fast-cycling valves and cylinders. Two sub-series: **R60** models with durable plastic dome, and **R75** models with high-strength metal dome for more severe environments. Regulation performance is essentially the same.

## SERIES 350, SERIES 380 and VANGUARD REGULATORS

Port sizes 1/4 to 3/4. Modular units with diaphragm design for sensitivity and accurate pressure regulation. An adjustment-locking key to prevent tampering is standard.

Full-Size **VANGUARD SERIES 350**, and **SERIES 380 PRECISION** regulators are also available. They are of diaphragm design, and were developed to give superior torque control with pneumatic tools. However, they are well suited to many other applications because of their ability to regulate very high air flows with great precision. They will hold regulated pressure within 3 psig (0.2 bar), and repeatability is within 0.5 psig (0.034 bar). For torque control and applications that cannot tolerate over-pressurization, regulated pressure can be limited to 85 psig (5.9 bar). Air from a constant bleed, which is important to the precision of these units, is normally inaudible.

## HIGH-FLOW VANGUARD REGULATORS

Port sizes 3/4 to 1-1/2. Inline mounting and piston design are featured in these high-air-flow models. An adjustment-locking key to prevent tampering is standard.

**PRECISION** High-Capacity regulators are also available. They are of diaphragm design, and have essentially the same precise operating characteristics as the Full-Size **VANGUARD** precision regulators described above. Their larger port sizes, however, make them the choice for very high-air-flow applications.

## EXTERNALLY PILOTED REGULATORS

Regulators operated with external pilots are as precise as the external pilot regulators used. A 1/4" R55M pilot regulator (or R57M precision model) provides an accurately controlled air spring for excellent regulation. The pilot control regulator can be installed at a distance from the main regulator for convenience in making adjustments.



Full-Size **VANGUARD PRH100** modular external relief piloted regulators use a diaphragm design for high sensitivity. They provide air flows up to 160 scfm (94 l/s) in applications where low pressure drop and/or remote adjusting are desired.

**High-Flow PR180 VANGUARD** external piloted regulators and **High-Flow PRH180 VANGUARD** external relief piloted regulators are of diaphragm design, and provide air flows up to 600 scfm (284 l/s).

**High-Flow R200 VANGUARD** Regulators provide air flows up to 1000 scfm (474 l/s). For fast response, good sensitivity, and long service life they employ a piston traveling in a hard-anodized, Teflon-impregnated, metal cylinder. A high-flow, self-relieving valve is built into the main regulator.

## RELIEF VALVES

Relief valves are set for a desired maximum system pressure, and inserted in a tee downstream of regulated pressure to prevent over-pressurization of the system beyond the relief valve setting. Relief valves are adjustable from 1 to 125 psig (0.07 to 8.6 bar). Optional springs are available for other pressure ranges. If pressure exceeds the relief valve setting it will dump system air to atmosphere or to a valve to provide a warning signal.



Port sizes 1/8 and 1/4. A pressure gauge is standard equipment.

## ELECTRO-PNEUMATIC SERVO VALVES



Electro-pneumatic servo valves employ the latest in closed loop control technology. Flow rate is typically one scfm, but when used with a volume booster a flow rate in excess of 1,000 scfm can be achieved.



# SENTRY Modular Externally Piloted Regulators

# PR11M Models Port Sizes: 1/8, 1/4 Tube Fittings



Model Shown: PR11M-1G

- ◆ Inline mounting.
- ◆ Diaphragm type design
- ◆ Threaded ports or quick-connect fittings for tubing up to 10 mm in diameter.
- ◆ Self-relieving; non-relieving optional.
- ◆ Pressure gauge.
- ◆ **NPTF** port threads; optional **BSPP** threads.

**Note:** Pilot (control) regulators (order separately).

- ◆ General purpose applications order R56M-2, R60-2, R67-2, R100-2, or R380-3
- ◆ Precision applications order IR100-2, R57M-2, IR380-3 or ER valve

## SPECIFICATIONS

**Ambient/Media Temperature:**

40° to 125°F (4° to 52°C).

**Body:** Acetal.

**Dome:** Aluminum.

**Fluid Media:** Compressed air.

**Inlet Pressure:** 150 psig (10 bar) maximum.

**Outlet Pressure:** Adjustable up to 125 psig (8.6 bar).

**Pressure Gauge:** 0 to 160 psig (11 bar); 1/8 NPT gauge ports front and rear.

**Panel Mounting:** 1-3/16 inch (30 mm) hole required.

**Seals:** Nitrile.

## FLOW CHART

Inlet Pressure: 91 psig (6.3 bar)

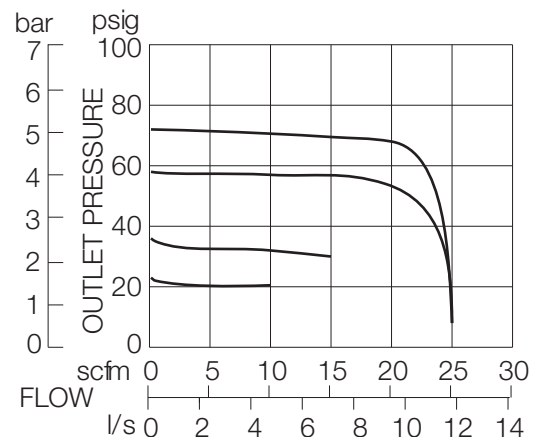

บริษัท ฟลูเทค จำกัด  
FLU-TECH CO.,LTD

845/3-4 หมู่ 3 ถ.เทพารักษ์ ต.เทพารักษ์ อ.เมือง จ.สมุทรปราการ 10270

845/3-4 Thepharak RD., T.Thepharak, A.Muang, Samutprakarn 10270 THAILAND

Tel. 0 2384 6060, Fax 0 2384 5701, Email : sales@flutech.co.th, www.flutech.co.th

## DIMENSIONS inches (mm)

Ports	A	B	C	Depth †	Weight †
					lb (kg)
No Port	1.7 (43)	1.3 (49)	0.5 (13)	1.8 (45)	0.23 (0.11)
1/8	1.7 (43)	1.3 (49)	0.5 (13)	1.8 (45)	0.45 (0.20)
1/4	3.0 (76)	1.3 (49)	0.5 (13)	1.8 (45)	0.41 (0.19)
<b>Models below have quick-connect fittings for tubing.</b>					
1/4	3.4 (86)	1.3 (49)	0.5 (13)	1.8 (45)	0.33 (0.15)
3/8	3.9 (99)	1.3 (49)	0.5 (13)	1.8 (45)	0.47 (0.22)
4 mm	3.4 (86)	1.3 (49)	0.5 (13)	1.8 (45)	0.33 (0.15)
6 mm	3.4 (86)	1.3 (49)	0.5 (13)	1.8 (45)	0.33 (0.15)
8 mm	3.4 (86)	1.3 (49)	0.5 (13)	1.8 (45)	0.33 (0.15)
10 mm	3.9 (99)	1.3 (49)	0.5 (13)	1.8 (45)	0.45 (0.21)

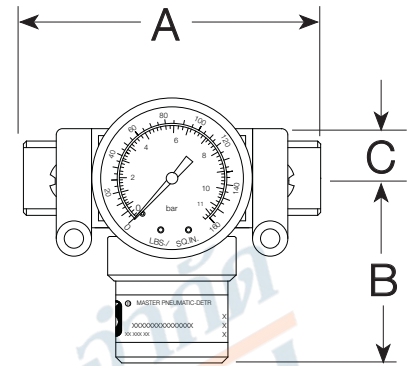

† Less gauge.

## ORDERING INFORMATION

Change the letters in the sample model number below to specify the regulator you want.

**PR11M P - 2 X Y G W**

### REGULATOR TYPE

Diaphragm type ..... R11M

### MOUNTING HOLE LOCATION

Bottom mount (Standard) ..... Leave Blank  
Top mount ..... P

### INLET PORT SIZE

No Inlet and Outlet ports ..... Leave blank

#### Threaded:

1/8 NPTF ..... -1  
1/4 NPTF ..... -2

#### Fittings for Tubing:

1/4 ..... -04  
3/8 ..... -06  
4 mm ..... -M4  
6 mm ..... -M6  
8 mm ..... -M8  
10 mm ..... -M10

### OUTLET PORT SIZE

Same as inlet port ..... Leave Blank

#### Threaded:

1/8 NPTF ..... 1  
1/4 NPTF ..... 2

#### Fittings for Tubing:

1/4 ..... 04  
3/8 ..... 06  
4 mm ..... M4  
6 mm ..... M6  
8 mm ..... M8  
10 mm ..... M10

### PORT TYPE

As specified in **INLET PORT** ..... Leave Blank  
BSP threads on both ports ..... W

### OPTIONS (More than one option can be chosen. Add in alphabetical order)

Delete gauge ..... Leave Blank  
0-160 PSI Gauge ..... G

### OPTIONS (More than one option can be chosen. Add in alphabetical order)

None ..... Leave Blank  
Non-relieving ..... A

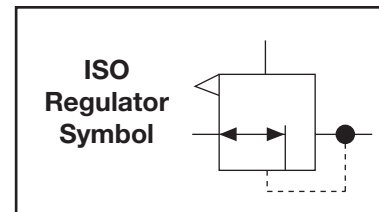

### MOUNTING BRACKETS

See page 356.



**บริษัท ฟลูเทค จำกัด**  
**FLU-TECH CO.,LTD**

845/3-4 หมู่ 3 ถ.เทพารักษ์ ต.เทพารักษ์ อ.เมือง จ.สมุทรปราการ 10270

845/3-4 Thepharak RD., T.Thepharak, A.Muang, Samutprakarn 10270 THAILAND

Tel. 0 2384 6060, Fax 0 2384 5701, Email : sales@flutech.co.th, www.flutech.co.th

# MINIATURE Externally Piloted Regulators

# PR55M, PR56M Models Port Sizes: 1/8, 1/4



Model Shown: PR56M-1G

- ◆ Inline mounting.
- ◆ Piston-type design (**PR55M** models) or diaphragm-type design (**PR56M** models)
- ◆ Self-relieving; non-relieving optional.
- ◆ Pressure gauge.
- ◆ **NPTF** port threads; optional **BSPP** threads.

**Note:** Pilot (control) regulators (order separately).

- ◆ General purpose applications order R56M-2, R60-2, R67-2, R100-2, or R380-3
- ◆ Precision applications order IR100-2, R57M-2, IR380-3 or ER valve

## SPECIFICATIONS

**Ambient/Media Temperature:**

40° to 125°F (4° to 52°C).

**Body and Dome:** Aluminum.

**Fluid Media:** Compressed air.

**Inlet Pressure:** 300 psig (21 bar) maximum.

**Outlet Pressure:** Adjustable up to 125 psig (8.6 bar).

**Pressure Gauge:** 0 to 160 psig (11 bar); 1/8 NPT gauge ports front and rear.

**Seals:** Nitrile.

## FLOW CHART

Inlet Pressure: 91 psig (6.3 bar)

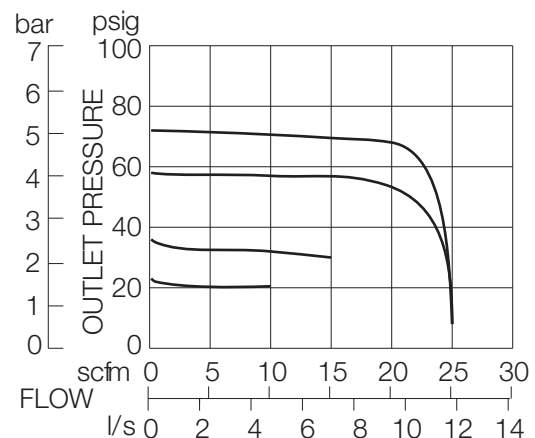

บริษัท ฟลูเทค จำกัด  
FLU-TECH CO.,LTD

845/3-4 หมู่ 3 ถ.เทพารักษ์ ต.เทพารักษ์ อ.เมือง จ.สมุทรปราการ 10270

845/3-4 Thepharak RD., T.Thepharak, A.Muang, Samutprakarn 10270 THAILAND  
Tel. 0 2384 6060, Fax 0 2384 5701, Email : sales@flutech.co.th, www.flutech.co.th



# Full-Size SERIES 380 Modular Externally Piloted Regulators

# PR380 Models Port Sizes: 3/8, 1/2, 3/4

## Available Color Caps



- ◆ Modular or inline mounting.
- ◆ Self-relieving diaphragm design.
- ◆ Pressure gauge.
- ◆ NPTF port threads; optional BSPP threads.

**Note:** Pilot (control) regulators (order separately).

- ◆ General purpose applications order R56M-2, R60-2, R67-2, R100-2, or R380-3
- ◆ Precision applications order IR100-2, R57M-2, IR380-3 or ER valve



Model Shown: PR380-6G

## SPECIFICATIONS

### Ambient/Media Temperature:

40° to 175°F (4° to 79°C).

**Body:** Zinc.

**Dome:** Zinc.

**Fluid Media:** Compressed air.

**Inlet Pressure:** 300 psig (21 bar) maximum.

**Outlet Pressure:** Adjustable 0 – 250 psig (0 – 17 bar).

**Pilot Ports:** 1/4 NPTF

**Pressure Gauge:** 0 to 200 psig (14 bar); 1/4 NPT gauge ports front and rear.

**Seals:** Nitrile.

**Valve:** Brass.

**Valve Cap:** Nylon.

## FLOW CHARTS

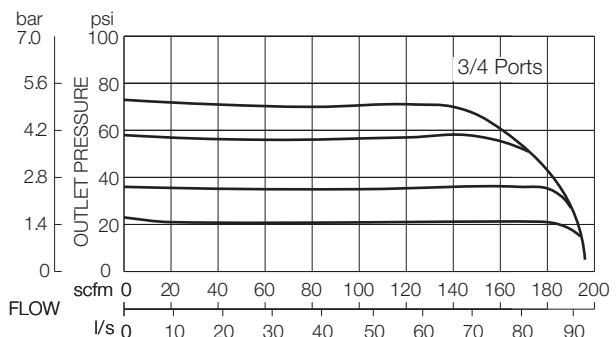
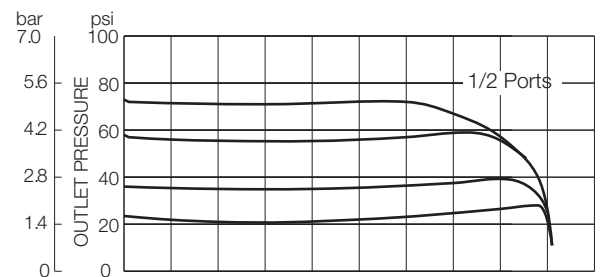
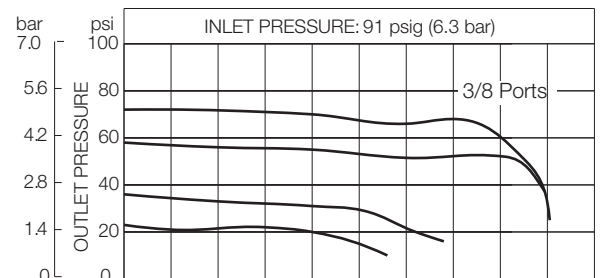

บริษัท ฟลูเทค จำกัด  
FLU-TECH CO.,LTD

845/3-4 หมู่ 3 ถ.เทพารักษ์ ต.เทพารักษ์ อ.เมือง จ.สมุทรปราการ 10270

845/3-4 Thepharak RD., T.Thepharak, A.Muang, Samutprakarn 10270 THAILAND

Tel. 0 2384 6060, Fax 0 2384 5701, Email : sales@flutech.co.th, www.flutech.co.th

## DIMENSIONS inches (mm)

A	B	C	Depth †	Weight † lb (kg)
3.5 (87)	2.4 (62)	1.6 (40)	2.9 (73)	2.20 (1.00)

† Less gauge.

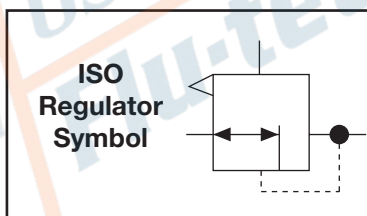
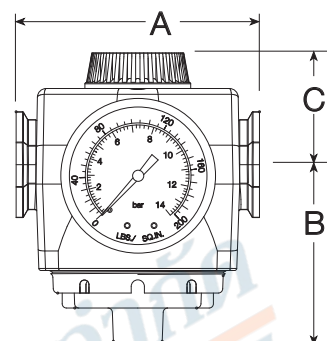

## ORDERING INFORMATION

Change the letters in the sample model number below to specify the regulator you want.

**NOTE:** Order a pilot operator such as **R55-2**, **R56-2**, or **IR100-2** separately.

**PR380 - 3 Y G W**

### PORT SIZE

3/8 NPTF.....	3
1/2 NPTF.....	4
3/4 NPTF.....	6

### PORT TYPE

NPTF threads .....	Leave Blank
BSP threads .....	W

### OPTIONS

None .....	Leave Blank
0-200 PSI Gauge .....	G

**OPTIONS** (More than one option can be chosen. Add in alphabetical order)

None .....	Leave Blank
Non-relieving .....	A
Cap Color: Grey is standard	
MP yellow .....	C1
Red.....	C2
Mid blue.....	C3

### MOUNTING BRACKETS

See page 356.



**บริษัท ฟลูเทค จำกัด**  
**FLU-TECH CO.,LTD**

845/3-4 หมู่ 3 ถ.เทพารักษ์ ต.เทพารักษ์ อ.เมือง จ.สมุทรปราการ 10270

845/3-4 Thepharak RD., T.Thepharak, A.Muang, Samutprakarn 10270 THAILAND

Tel. 0 2384 6060, Fax 0 2384 5701, Email : sales@flutech.co.th, www.flutech.co.th



# Full-Size SERIES 380 Modular External Relief Piloted Regulator

## PRH380 Models Port Sizes: 3/8, 1/2, 3/4

### Available Color Caps



- ◆ Modular or inline mounting.
- ◆ Self-relieving diaphragm design.
- ◆ Pressure gauge.
- ◆ NPTF port threads; optional BSPP threads.

**Note:** Pilot (control) regulators (order separately).

- ◆ General purpose applications order R56M-2, R60-2, R67-2, R100-2, or R380-3
- ◆ Precision applications order IR100-2, R57M-2, IR380-3 or ER valve



Model Shown: PRH380-6G

### SPECIFICATIONS

**Ambient/Media Temperature:**

40° to 175°F (4° to 79°C).

**Body:** Zinc.

**Dome:** Zinc.

**Fluid Media:** Compressed air.

**Inlet Pressure:** 300 psig (21 bar) maximum.

**Outlet Pressure:** Adjustable 0 – 250 psig (0 – 17 bar).

**Pilot Ports:** 1/4 NPTF

**Pressure Gauge:** 0 to 200 psig (14 bar); 1/4 NPT gauge ports front and rear.

**Seals:** Nitrile.

**Valve:** Brass.

**Valve Cap:** Nylon.

### FLOW CHARTS

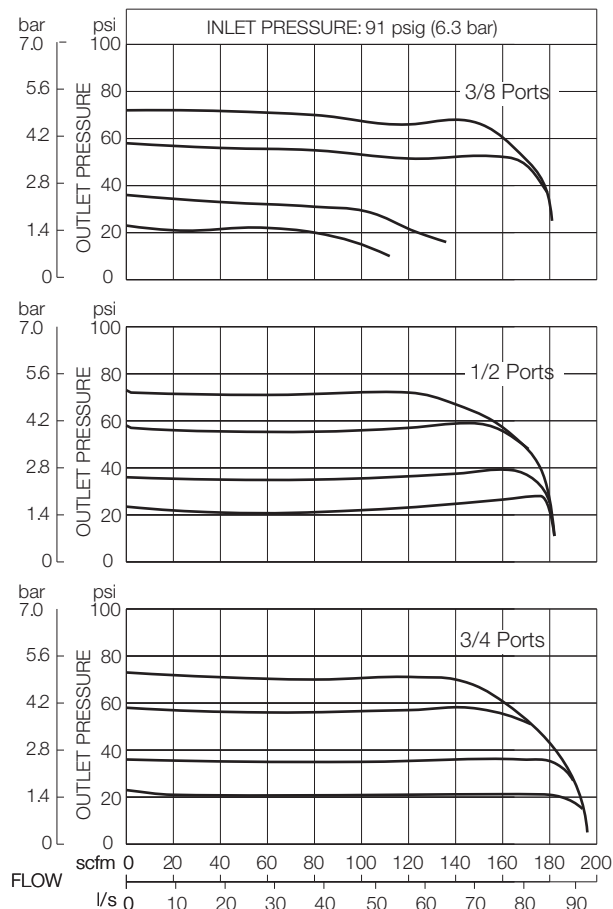

บริษัท ฟลูเทค จำกัด  
FLU-TECH CO.,LTD

845/3-4 หมู่ 3 ถ.เทพารักษ์ ต.เทพารักษ์ อ.เมือง จ.สมุทรปราการ 10270

845/3-4 Thepharak RD., T.Thepharak, A.Muang, Samutprakarn 10270 THAILAND

Tel. 0 2384 6060, Fax 0 2384 5701, Email : sales@flutech.co.th, www.flutech.co.th

## DIMENSIONS inches (mm)

A	B	C	Depth †	Weight †
				lb (kg)
3.5 (87)	2.4 (62)	1.6 (40)	2.9 (73)	2.20 (1.00)

† Less gauge.

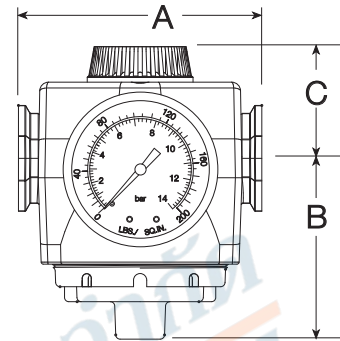

### ISO Symbol

With conventional pilot regulator

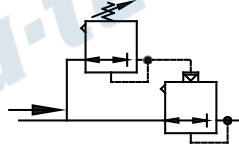

## ORDERING INFORMATION

Change the letters in the sample model number below to specify the regulator you want.

**NOTE:** Order a pilot operator such as **R55-2**, **R56-2**, or **IR100-2** separately.

**PRH380 - 3 Y G W**

### PORT SIZE

3/8 NPTF.....	3
1/2 NPTF.....	4
3/4 NPTF.....	6

### PORT TYPE

NPTF threads .....	Leave Blank
BSPP threads .....	W

### OPTIONS

None .....	Leave Blank
0-200 PSI Gauge .....	G

**OPTIONS** (More than one option can be chosen. Add in alphabetical order)

None .....	Leave Blank
Non-relieving .....	A
Cap Color: Grey is standard	
MP yellow .....	C1
Red .....	C2
Mid blue .....	C3

### MOUNTING BRACKETS

See page 356.



**บริษัท ฟลูเทค จำกัด**  
**FLU-TECH CO.,LTD**

845/3-4 หมู่ 3 ถ.เทพารักษ์ ต.เทพารักษ์ อ.เมือง จ.สมุทรปราการ 10270

845/3-4 Thepharak RD., T.Thepharak, A.Muang, Samutprakarn 10270 THAILAND

Tel. 0 2384 6060, Fax 0 2384 5701, Email : sales@flutech.co.th, www.flutech.co.th

# Full-Size VANGUARD Modular Externally Piloted Regulators

# PR100 Models Port Sizes: 1/4, 3/8, 1/2, 3/4



Model Shown: PR100-6G

- ◆ Modular or inline mounting.
- ◆ Self-relieving diaphragm design.
- ◆ Pressure gauge.
- ◆ NPTF port threads; optional BSPP threads.

**Note:** Pilot (control) regulators (order separately).

- ◆ General purpose applications order R56M-2, R60-2, R67-2, R100-2, or R380-3
- ◆ Precision applications order IR100-2, R57M-2, IR380-3 or ER valve

## SPECIFICATIONS

**Ambient/Media Temperature:**

40° to 175°F (4° to 79°C).

**Body:** Zinc.

**Dome:** Zinc.

**Fluid Media:** Compressed air.

**Inlet Pressure:** 300 psig (21 bar) maximum.

**Outlet Pressure:** Adjustable 0 – 200 psig (0 – 14 bar).

**Pilot Ports:** 1/4 NPTF

**Pressure Gauge:** 0 to 200 psig (14 bar); 1/4 NPT gauge ports front and rear.

**Seals:** Nitrile.

**Valve:** Brass.

**Valve Cap:** Nylon.

## FLOW CHARTS

Inlet Pressure: 100 psig (7 bar)

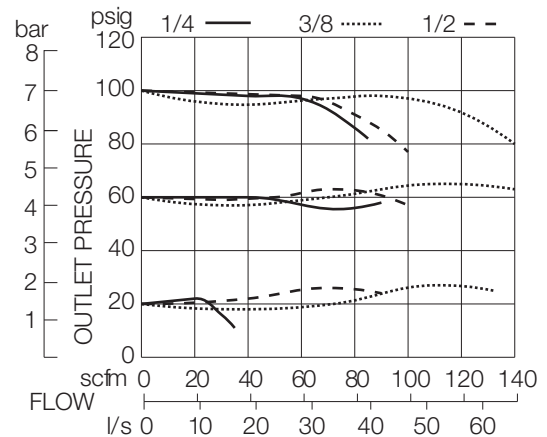

บริษัท ฟลูเทค จำกัด  
FLU-TECH CO.,LTD

845/3-4 หมู่ 3 ถ.เทพารักษ์ ต.เทพารักษ์ อ.เมือง จ.สมุทรปราการ 10270

845/3-4 Thepharak RD., T.Thepharak, A.Muang, Samutprakarn 10270 THAILAND

Tel. 0 2384 6060, Fax 0 2384 5701, Email : sales@flutech.co.th, www.flutech.co.th

## DIMENSIONS inches (mm)

A	B	C	Depth †	Weight † lb (kg)
3.5 (89)	2.4 (62)	1.3 (33)	2.8 (71)	2.06 (0.92)

† Less gauge.

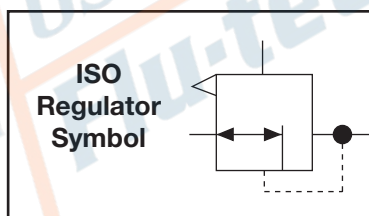
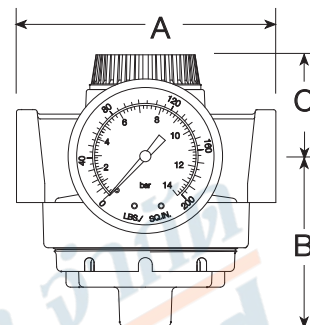

## ORDERING INFORMATION

Change the letters in the sample model number below to specify the regulator you want.

**NOTE:** Order a pilot operator such as **R55-2**, **R56-2**, or **IR100-2** separately.

**PR100 - 2 Y G W**

### PORT SIZE

1/4 NPTF.....	2
3/8 NPTF.....	3
1/2 NPTF.....	4
3/4 NPTF.....	6

### PORT TYPE

NPTF threads .....	Leave Blank
BSP threads .....	W

### OPTION

None .....	Leave Blank
0-200 PSI Gauge .....	G

### OPTION

None .....	Leave Blank
Non-relieving .....	A

### MOUNTING BRACKETS

See page 356.



**บริษัท ฟลูเทค จำกัด**  
**FLU-TECH CO.,LTD**

845/3-4 หมู่ 3 ถ.เทพารักษ์ ต.เทพารักษ์ อ.เมือง จ.สมุทรปราการ 10270

845/3-4 Thepharak RD., T.Thepharak, A.Muang, Samutprakarn 10270 THAILAND

Tel. 0 2384 6060, Fax 0 2384 5701, Email : sales@flutech.co.th, www.flutech.co.th

# Full-Size VANGUARD Modular External Relief Piloted Regulator

**PRH100 Models**  
**Port Sizes: 1/4, 3/8, 1/2, 3/4**



Model Shown: PRH100-6G

## SPECIFICATIONS

**Ambient/Media Temperature:**

40° to 175°F (4° to 79°C).

**Body:** Zinc.

**Dome:** Zinc.

**Fluid Media:** Compressed air.

**Inlet Pressure:** 300 psig (21 bar) maximum.

**Outlet Pressure:** Adjustable 0 – 200 psig (0 – 14 bar).

**Pilot Ports:** 1/4 NPTF

**Pressure Gauge:** 0 to 200 psig (14 bar); 1/4 NPT gauge ports front and rear.

**Seals:** Nitrile; optional Viton seals.

**Valve:** Brass.

**Valve Cap:** Nylon.

External relief piloted regulators separate control air from exhaust air.

- ◆ Modular or inline mounting.
- ◆ Diaphragm-type design.
- ◆ Self-relieving.
- ◆ Pressure gauge.
- ◆ NPTF port threads; optional BSPP threads.

**Note:** Pilot (control) regulators (order separately).

- ◆ General purpose applications order R56M-2, R60-2, R67-2, R100-2, or R380-3
- ◆ Precision applications order IR100-2, R57M-2, IR380-3 or ER valve

## FLOW CHARTS

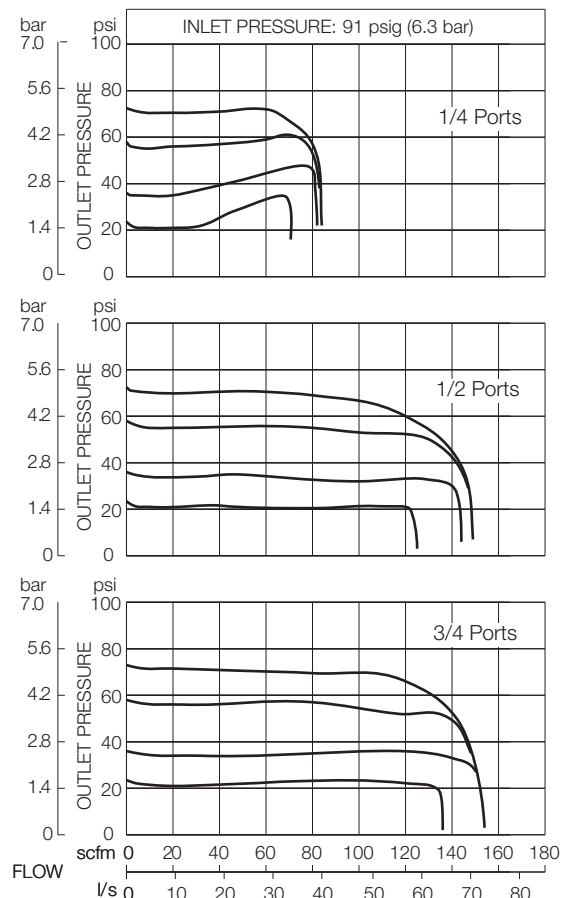

**บริษัท ฟลูเทค จำกัด**  
**FLU-TECH CO.,LTD**

845/3-4 หมู่ 3 ถ.เทพารักษ์ ต.เทพารักษ์ อ.เมือง จ.สมุทรปราการ 10270

845/3-4 Thepharak RD., T.Thepharak, A.Muang, Samutprakarn 10270 THAILAND

Tel. 0 2384 6060, Fax 0 2384 5701, Email : sales@flutech.co.th, www.flutech.co.th

## DIMENSIONS inches (mm)

A	B	C	Depth †	Weight † lb (kg)
3.5 (89)	2.4 (62)	1.3 (33)	2.8 (71)	2.06 (0.92)

† Less gauge.

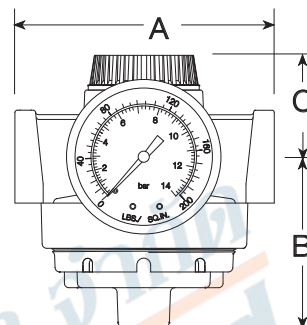

### ISO Symbol

With conventional  
pilot regulator

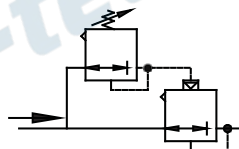

## ORDERING INFORMATION

Change the letters in the sample model number below to specify the regulator you want.

**NOTE:** Order a pilot operator such as **R55-2**, **R56-2**, or **IR100-2** separately.

**PRH100 - 2 Y G W**

### PORT SIZE

1/4 NPTF.....	2
3/8 NPTF.....	3
1/2 NPTF.....	4
3/4 NPTF.....	6

### PORT TYPE

NPTF threads .....	Leave Blank
BSPF threads .....	W

### OPTION

None .....	Leave Blank
0-200 PSI Gauge .....	G

### OPTION

None .....	Leave Blank
Viton seals.....	V

### MOUNTING BRACKETS

See page 356.



**บริษัท ฟลูเทค จำกัด**  
**FLU-TECH CO.,LTD**

845/3-4 หมู่ 3 ถ.เทพารักษ์ ต.เทพารักษ์ อ.เมือง จ.สมุทรปราการ 10270

845/3-4 Thepharak RD., T.Thepharak, A.Muang, Samutprakarn 10270 THAILAND

Tel. 0 2384 6060, Fax 0 2384 5701, Email : sales@flutech.co.th, www.flutech.co.th

# Full-Size VANGUARD High-Relief Externally Piloted Regulator

## HPR100 Models Port Sizes: 1/4, 3/8, & 1/2



Model Shown: HPR100-3G1

### SPECIFICATIONS

**Ambient/Media Temperature:**

0° to 158°F (-18° to 70°C).

**Body and Dome:** Aluminum.

**Seals:** Nitrile.

**Valve:** Brass.

**Valve Cap:** Glass filled Nylon.

**Fluid Media:** Compressed air.

**Inlet Pressure:**

10 psig (0.7 bar) minimum.

400 psig (27.6 bar) maximum.

**Outlet Pressure:** 0 to 250 psig (0 to 17.3 bar).

**Pilot Ports:** 1/4 NPTF.

**Pressure Gauge:** 0 to 200 psig (0 to 14 bar);

Optional 0 to 600 psig (0 to 41.4 bar).

1/4-NPTF Inlet/Outlet ports, 1/4-NPTF gauge ports.

3/8-NPTF Inlet/Outlet ports, 3/8-NPTF gauge ports.

1/2-NPTF Inlet/Outlet ports, 1/2-NPTF gauge ports.

Designed for systems that require high-relief and pressure regulation. Can be installed in an inaccessible location with a control regulator in an accessible location.

- ◆ Inline mounting.
- ◆ Diaphragm-type design.
- ◆ Optional pressure gauges.
- ◆ Flow rates exceed 150 scfm.
- ◆ NPTF port threads; optional BSPP threads.
- ◆ High relief characteristics up-to 200 scfm.

**Note:** Pilot (control) regulators (ordered separately).

- ◆ General purpose applications order R56M-2, R60-2, R67-2, R100-2, or R380-3
- ◆ Precision applications order IR100-2, R57M-2, IR380-3 or ER valve.

### FLOW CHARTS

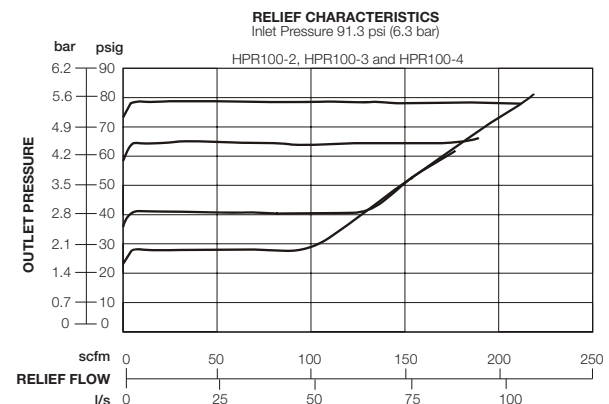
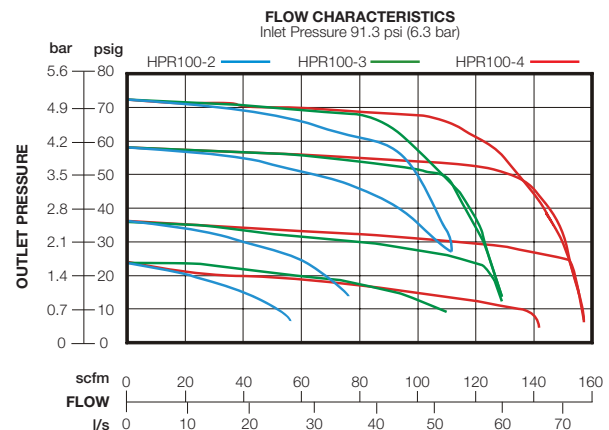

บริษัท ฟลูเทค จำกัด  
FLU-TECH CO.,LTD

845/3-4 หมู่ 3 ถ.เทพารักษ์ ต.เทพารักษ์ อ.เมือง จ.สมุทรปราการ 10270

845/3-4 Thepharak RD., T.Thepharak, A.Muang, Samutprakarn 10270 THAILAND

Tel. 0 2384 6060, Fax 0 2384 5701, Email : sales@flutech.co.th, www.flutech.co.th

## DIMENSIONS inches (mm)

A	B	C	Depth †	Weight † lb (kg)
4.18 (106.0)	3.52 (89.3)	1.54 (39.1)	4.18 (106)	4.84 (2.2)

† Less gauge.

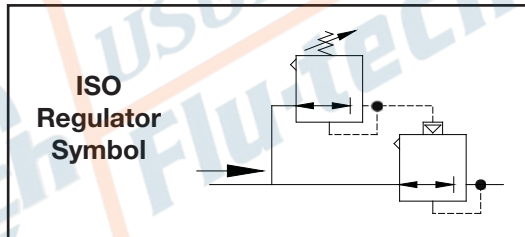
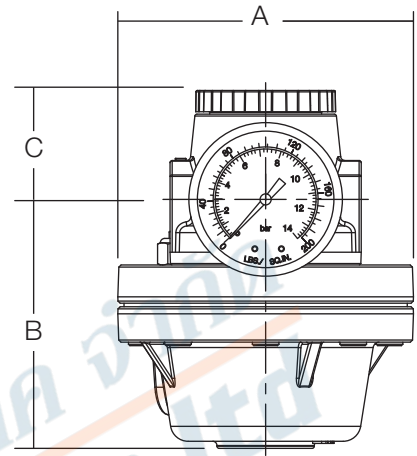

## ORDERING INFORMATION

Change the letters in the sample model number below to specify the regulator you want.

**NOTE:** Order a pilot operator such as **R55-2**, **R56-2**, or **IR100-2** separately.

# HPR100 - 3 G W

### PORT and GAUGE PORT SIZE

- 1/4-NPTF Inlet/Outlet ..... 2  
1/4-NPTF gauge ports.
- 3/8-NPTF Inlet/Outlet ..... 3  
3/8-NPTF gauge ports.
- 1/2-NPTF Inlet/Outlet ..... 4  
1/2-NPTF gauge ports.

### PORT TYPE

- NPTF threads ..... Leave Blank
- BSPP threads ..... W

### OPTION

- None ..... Leave Blank
- 0-200 PSI Gauge \* ..... G
- 0-600 PSI Gauge \* ..... G1

\* = Reducing bushings are used in any gauge ports other than 1/4". Port size 3/8 and 1/2 will require bushings. (see accessories page for gauge kits with bushings).



**บริษัท ฟลูเทค จำกัด**  
**FLU-TECH CO.,LTD**

845/3-4 หมู่ 3 ถ.เทพารักษ์ ต.เทพารักษ์ อ.เมือง จ.สมุทรปราการ 10270

845/3-4 Thepharak RD., T.Thepharak, A.Muang, Samutprakarn 10270 THAILAND

Tel. 0 2384 6060, Fax 0 2384 5701, Email : sales@flutech.co.th, www.flutech.co.th



# High-Flow VANGUARD Externally Piloted Regulators

# PR180M Models Port Sizes: 3/4, 1, 1-1/4, 1-1/2



Model Shown: PR180M-6G

- ◆ Inline mounting.
- ◆ Diaphragm-type design.
- ◆ Self-relieving.
- ◆ Pressure gauge.
- ◆ NPTF port threads; optional BSPP threads.
- ◆ @ 80 psi with 15 psi back pressure the relief is 6.25 scfm - Needs control regulator that relieves more than this.

**Note:** Pilot (control) regulators (order separately).

- ◆ General purpose applications order R56M-2, R60-2, R67-2, R100-2, or R380-3
- ◆ Precision applications order IR100-2, R57M-2, IR380-3 or ER valve

## SPECIFICATIONS

**Ambient/Media Temperature:**

40° to 175°F (4° to 79°C).

**Body:** Aluminum.

**Dome:** Zinc.

**Fluid Media:** Compressed air.

**Inlet Pressure:** 300 psig (21 bar) maximum.

**Outlet Pressure:** 0 to 200 psig (0 to 14 bar).

**NOTE:** Outlet pressure depends on the selection of the pilot regulator.

**Pilot Ports:** 1/4 NPTF.

**Pressure Gauge:** 0 to 200 psig (14 bar); 1/4 NPT gauge ports front and rear.

**Seals:** Nitrile.

**Valve:** Aluminum.

**Valve Cap:** Nylon.

## FLOW CHART

Inlet Pressure: 100 psig (7 bar)

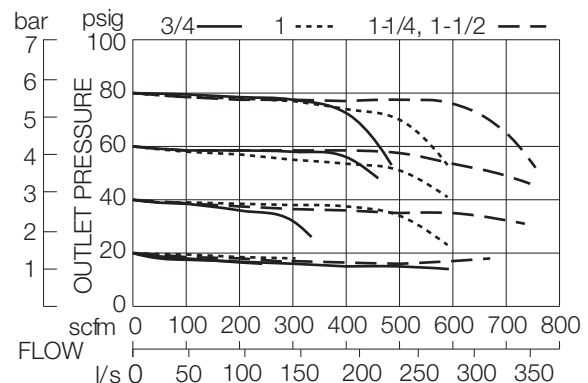

บริษัท ฟลูเทค จำกัด  
FLU-TECH CO.,LTD

845/3-4 หมู่ 3 ถ.เทพารักษ์ ต.เทพารักษ์ อ.เมือง จ.สมุทรปราการ 10270

845/3-4 Thepharak RD., T.Thepharak, A.Muang, Samutprakarn 10270 THAILAND

Tel. 0 2384 6060, Fax 0 2384 5701, Email : sales@flutech.co.th, www.flutech.co.th

**DIMENSIONS** inches (mm)

Ports	A	B	C	Depth †	Weight †
					lb (kg)
3/4 1	4.4 (111)	2.9 (74)	2.4 (62)	2.8 (71)	1.88 (0.85)
1-1/4 1-1/2	4.9 (124)	3.2 (81)	2.1 (54)	2.8 (71)	2.25 (1.02)

† Less gauge.

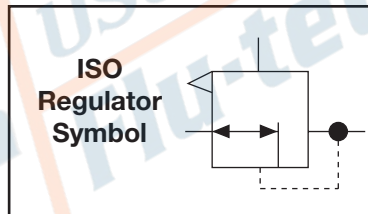
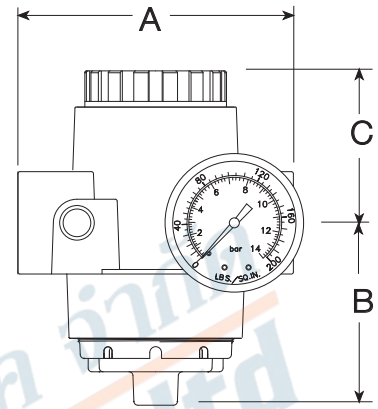

**ORDERING INFORMATION**

Change the letters in the sample model number below to specify the regulator you want.

**NOTE:** Order a pilot operator such as **R55-2**, **R56-2**, or **IR100-2** separately.

**PR180M - 6 Y G W**

**PORT SIZE**

- 3/4 NPTF ..... 6
- 1 NPTF ..... 8
- 1-1/4 NPTF ..... 10\*
- 1-1/2 NPTF ..... 12\*

**PORT TYPE**

- NPTF threads ..... Leave Blank
- BSPF threads ..... W

**OPTION**

- None ..... Leave Blank
- 0-200 PSI Gauge ..... G

**OPTION**

- None ..... Leave Blank
- Non-relieving ..... A

\* No mounting bracket available.



**บริษัท ฟลูเทค จำกัด**  
**FLU-TECH CO.,LTD**

845/3-4 หมู่ 3 ถ.เทพารักษ์ ต.เทพารักษ์ อ.เมือง จ.สมุทรปราการ 10270

845/3-4 Thepharak RD., T.Thepharak, A.Muang, Samutprakarn 10270 THAILAND

Tel. 0 2384 6060, Fax 0 2384 5701, Email : sales@flutech.co.th, www.flutech.co.th

# High-Flow VANGUARD External Relief Piloted Regulator

## PRH180M Models Port Sizes: 3/4, 1, 1-1/4, 1-1/2



Model Shown: PRH180M-8G

### SPECIFICATIONS

**Ambient/Media Temperature:**

40° to 175°F (4° to 79°C).

**Body:** Aluminum.

**Dome:** Zinc.

**Fluid Media:** Compressed air.

**Inlet Pressure:** 300 psig (21 bar) maximum.

**Outlet Pressure:** 0 to 200 psig (0 to 14 bar).

**Pilot Ports:** 1/4 NPTF.

**Pressure Gauge:** 0 to 200 psig (14 bar); 1/4 NPT gauge ports front and rear.

**Seals:** Nitrile.

**Valve:** Aluminum.

**Valve Cap:** Nylon.

**Note:** Pilot (control) regulators (order separately).

- ◆ General purpose applications order R56M-2, R60-2, R67-2, R100-2, or R380-3
- ◆ Precision applications order IR100-2, R57M-2, IR380-3 or ER valve

High-Flow external relief piloted regulator separate control air from exhaust air.

- ◆ Inline mounting.
- ◆ Diaphragm-type design.
- ◆ Self-relieving.
- ◆ Pressure gauge.
- ◆ NPTF port threads; optional BSPP threads.
- ◆ @ 80 psi with 15 psi back pressure the relief is 10 scfm.

### FLOW CHARTS

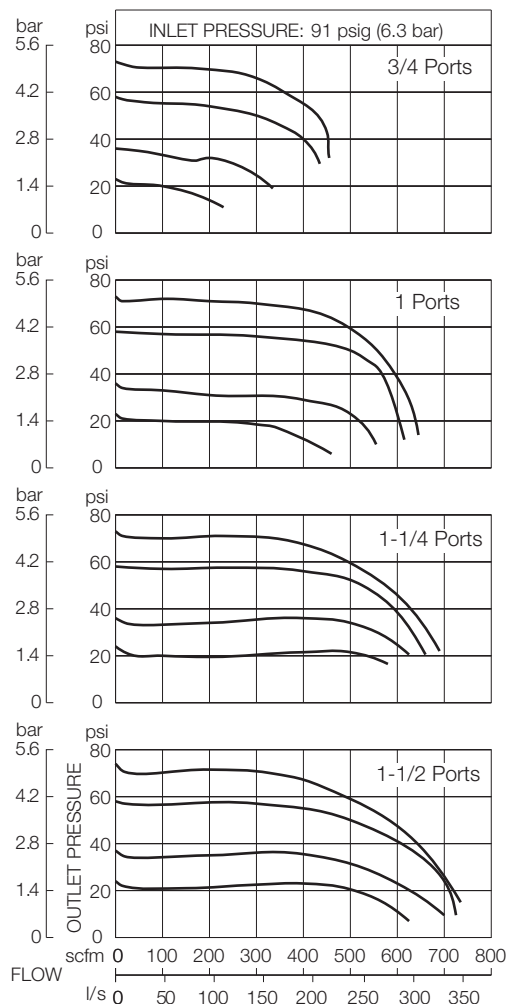

บริษัท ฟลูเทค จำกัด  
FLU-TECH CO.,LTD

845/3-4 หมู่ 3 ถ.เทพารักษ์ ต.เทพารักษ์ อ.เมือง จ.สมุทรปราการ 10270

845/3-4 Thepharak RD., T.Thepharak, A.Muang, Samutprakarn 10270 THAILAND

Tel. 0 2384 6060, Fax 0 2384 5701, Email : sales@flutech.co.th, www.flutech.co.th

**DIMENSIONS** inches (mm)

Ports	A	B	C	Depth †	Weight †
					lb (kg)
3/4	4.4	2.9	2.4	2.8	1.88
1	(111)	(74)	(62)	(71)	(0.85)
1-1/4	4.9	3.2	2.1	2.8	2.25
1-1/2	(124)	(81)	(54)	(71)	(1.02)

† Less gauge.

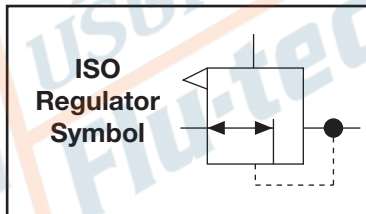
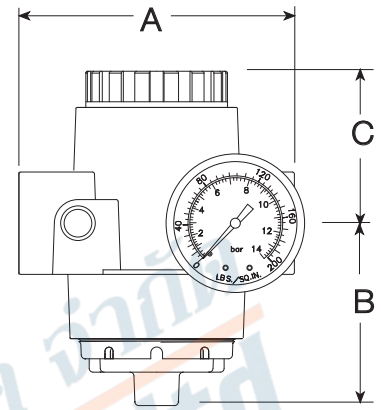

**ORDERING INFORMATION**

Change the letters in the sample model number below to specify the regulator you want.

**NOTE:** Order a pilot operator such as **R55-2**, **R56-2**, or **IR100-2** separately.

**PRH180M - 6 G W**

**PORT SIZE**

- 3/4 NPTF ..... 6
- 1 NPTF ..... 8
- 1-1/4 NPTF ..... 10\*
- 1-1/2 NPTF ..... 12\*

**PORT TYPE**

- NPTF threads ..... Leave Blank
- BSPB threads ..... W

**OPTION**

- None ..... Leave Blank
- 0-200 PSI Gauge ..... G

\* No mounting bracket available.



**บริษัท ฟลูเทค จำกัด**  
**FLU-TECH CO.,LTD**

845/3-4 หมู่ 3 ถ.เทพารักษ์ ต.เทพารักษ์ อ.เมือง จ.สมุทรปราการ 10270

845/3-4 Thepharak RD., T.Thepharak, A.Muang, Samutprakarn 10270 THAILAND  
Tel. 0 2384 6060, Fax 0 2384 5701, Email : sales@flutech.co.th, www.flutech.co.th

# High-Flow VANGUARD High-Relief Externally Piloted Regulator

## HPR180 Models Port Sizes: 3/4, 1 & 1-1/4



Model Shown: HPR180-8G1

### SPECIFICATIONS

**Ambient/Media Temperature:**

0° to 158°F (-18° to 70°C).

**Body and Dome:** Zinc.

**Seals:** Nitrile.

**Valve:** Brass.

**Valve Cap:** Glass filled Nylon.

**Fluid Media:** Compressed air.

**Inlet Pressure:**

10 psig (0.7 bar) minimum.

400 psig (27.6 bar) maximum.

**Outlet Pressure:** 0 to 250 psig (0 to 17.3 bar).

**Pilot Ports:** 1/4 NPTF.

**Pressure Gauge:** 0 to 200 psig (0 to 14 bar);

Optional 0 to 600 psig (0 to 41.4 bar).

3/4-NPTF Inlet/Outlet ports, 1/2-NPTF gauge ports.

1-NPTF Inlet/Outlet ports, 1/2-NPTF gauge ports.

1-1/4-NPTF Inlet/Outlet ports, 1/2-NPTF gauge ports.

Designed for systems that require high flow, relief and pressure regulation. Can be installed in an inaccessible location with a control regulator in an accessible location.

- ◆ Inline mounting.
- ◆ Diaphragm-type design.
- ◆ Optional pressure gauges.
- ◆ Flow rates exceed 400 scfm.
- ◆ NPTF port threads; optional BSPP threads.
- ◆ High relief characteristics up-to 200 scfm.

**Note:** Pilot (control) regulators (ordered separately).

- ◆ General purpose applications order **R56M-2, R60-2, R67-2, R100-2, or R380-3**
- ◆ Precision applications order **IR100-2, R57M-2, IR380-3** or **ER** valve.

### FLOW CHARTS

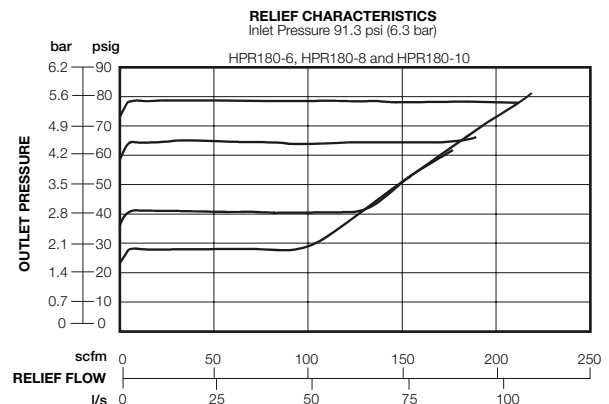
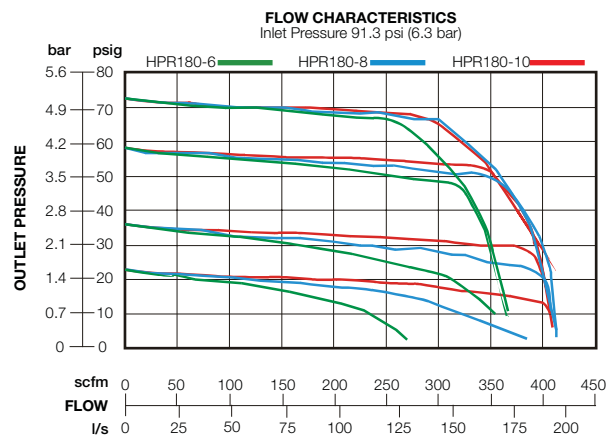

บริษัท ฟลูเทค จำกัด  
FLU-TECH CO.,LTD

845/3-4 หมู่ 3 ถ.เทพารักษ์ ต.เทพารักษ์ อ.เมือง จ.สมุทรปราการ 10270

845/3-4 Thepharak RD., T.Thepharak, A.Muang, Samutprakarn 10270 THAILAND

Tel. 0 2384 6060, Fax 0 2384 5701, Email : sales@flutech.co.th, www.flutech.co.th

**DIMENSIONS** inches (mm)

				Weight †
A	B	C	Depth †	lb (kg)
4.18 (106.0)	3.99 (101.3)	1.87 (47.5)	4.18 (106)	6.44 (3.0)

† Less gauge.

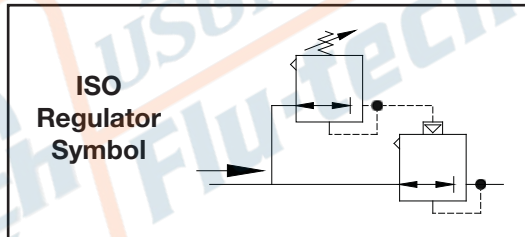
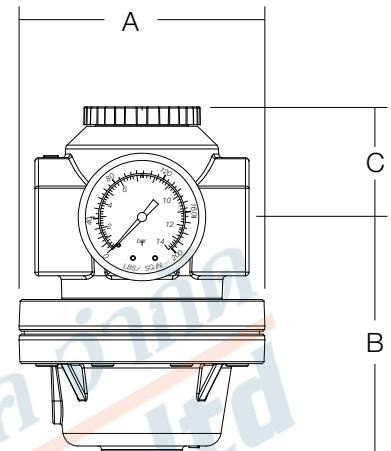

**ORDERING INFORMATION**

Change the letters in the sample model number below to specify the regulator you want.

**NOTE:** Order a pilot operator such as **R55-2**, **R56-2**, or **IR100-2** separately.

**HPR180 - 10 G W**

**PORT and GAUGE PORT SIZE**

- 3/4 NPTF Inlet/Outlet..... 6  
1/2-NPTF gauge ports.
- 1 NPTF Inlet/Outlet ..... 8  
1/2-NPTF gauge ports.
- 1-1/4 NPTF Inlet/Outlet ..... 10  
1/2-NPTF gauge ports.

**PORT TYPE**

- NPTF threads ..... Leave Blank
- BSPP threads ..... W

**OPTION**

- None ..... Leave Blank
- 0-200 PSI Gauge \* ..... G
- 0-600 PSI Gauge \* ..... G1

\* = Reducing bushings are used in any gauge ports other than 1/4".



**บริษัท ฟลูเทค จำกัด**  
**FLU-TECH CO.,LTD**

845/3-4 หมู่ 3 ถ.เทพารักษ์ ต.เทพารักษ์ อ.เมือง จ.สมุทรปราการ 10270

845/3-4 Thepharak RD., T.Thepharak, A.Muang, Samutprakarn 10270 THAILAND

Tel. 0 2384 6060, Fax 0 2384 5701, Email : sales@flutech.co.th, www.flutech.co.th

# High-Flow VANGUARD Externally Piloted Regulators

## R200 Models Port Sizes: 1-1/2, 2



Model Shown: R200-12G

- ◆ Inline mounting.
- ◆ Piston-type design.
- ◆ Self-relieving.
- ◆ Pressure gauge.
- ◆ NPTF port threads; optional BSPP threads.

**Note:** Pilot (control) regulators (order separately).

- ◆ General purpose applications order R56M-2, R60-2, R67-2, R100-2, or R380-3
- ◆ Precision applications order IR100-2, R57M-2, IR380-3 or ER valve

### SPECIFICATIONS

**Ambient/Media Temperature:**

40° to 175°F (4° to 79°C).

**Body and Dome:** Aluminum.

**Fluid Media:** Compressed air.

**Inlet Pressure:** 300 psig (21 bar) maximum.

**Outlet Pressure:** 0 to 200 psig (0 to 14 bar).

**NOTE:** Outlet pressure depends on the selection of the control regulator.

**Pilot Ports:** 1/4 NPTF.

**Pressure Gauge:** 0 to 200 psig (14 bar); 1/4 NPT gauge ports front and rear.

**Seals:** Nitrile; optional Viton seals.

**Valve:** Brass.

**Valve Cap:** Aluminum.

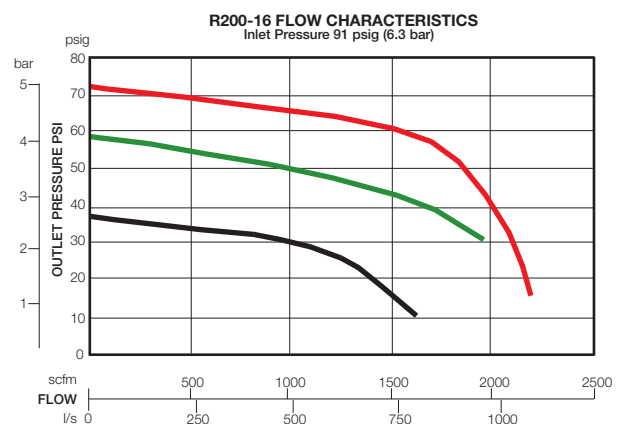

บริษัท ฟลูเทค จำกัด  
FLU-TECH CO.,LTD

845/3-4 หมู่ 3 ถ.เทพารักษ์ ต.เทพารักษ์ อ.เมือง จ.สมุทรปราการ 10270

845/3-4 Thepharak RD., T.Thepharak, A.Muang, Samutprakarn 10270 THAILAND  
Tel. 0 2384 6060, Fax 0 2384 5701, Email : sales@flutech.co.th, www.flutech.co.th

## DIMENSIONS inches (mm)

A	B	C	Depth †	Weight †
				lb (kg)
6.4 (162)	5.0 (127)	3.0 (76)	5.8 (147)	8.94 (4.06)

† Less gauge.

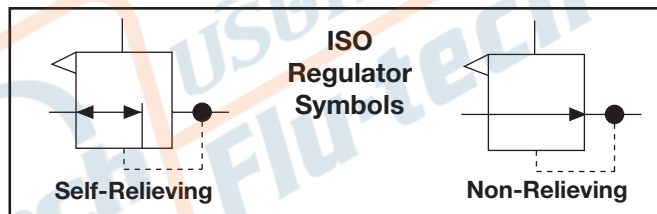
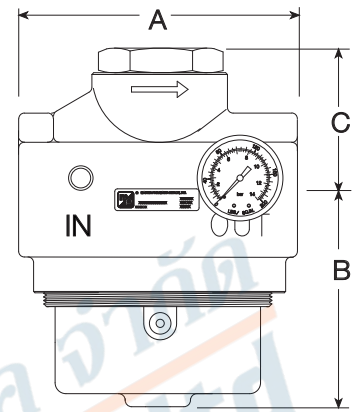

## ORDERING INFORMATION

Change the letters in the sample model number below to specify the regulator you want.

**NOTE:** Order a control regulator such as R55M, R56M, R57M, R100, R380, IR100, or IR180 separately.

**R20 0 - 12 Y G W**

### REGULATOR TYPE

Standard Regulator ..... 0  
 Standard Regulator with ..... 2  
 internal bias spring and gauge  
 port plugged.

### PORT SIZE

1-1/2 NPTF ..... 12  
 2 NPTF ..... 16

### OPTIONS (More than one option can be chosen)

None ..... Leave Blank  
 Non-relieving ..... A  
 Constant bleed ..... Q  
 Option '0' must be chosen  
 under REGULATOR TYPE.  
 Viton seals ..... V

### PORT TYPE

NPTF threads ..... Leave Blank  
 BSPP threads ..... W

### OPTION

None ..... Leave Blank  
 0-200 PSI Gauge ..... G



**บริษัท ฟลูเทค จำกัด**  
**FLU-TECH CO.,LTD**

845/3-4 หมู่ 3 ถ.เทพารักษ์ ต.เทพารักษ์ อ.เมือง จ.สมุทรปราการ 10270

845/3-4 Thepharak RD., T.Thepharak, A.Muang, Samutprakarn 10270 THAILAND

Tel. 0 2384 6060, Fax 0 2384 5701, Email : sales@flutech.co.th, www.flutech.co.th



# High-relief pilot operated regulator

## HPR251 Models Port Sizes: 1-1/2, 2



Model Shown: HPR251-12G

### SPECIFICATIONS

**Inlet Pressure Range:**

10 PSIG (min) to 450 PSIG (max) (0.7 TO 31 bar)

**Outlet PSI Range:** 0-250 PSI (17.2 bar)

**Operating Temp:** 0°F TO 175°F (-18°C to 79°C)  
(Air moisture content must be dry)

**Flow Rating:** Flow rates exceed 2,000 SCFM.

**Body:** Cast aluminum

**Dome:** Cast aluminum

**Cap:** Teflon coated aluminum

**Valve:** Nitrile bonded aluminum

**Elastomers:** Nitrile

**Ports:** 2" or 1-1/2-NPTF

**Gauge Ports:** 1/4-NPTF

**Exhaust Port:** 3/4-NPTF

Designed for systems that require high flow, high-relief and pressure regulation. This unit can be installed in an inaccessible location with a control regulator in an accessible location.

- ◆ Diaphragm design. Excellent pressure regulation and stability.
- ◆ High-relief characteristics up to 200 SCFM.
- ◆ Balanced valve minimizes effect of pressure changes on inlet pressure.
- ◆ Inline mounting.
- ◆ 3/4-14 NPTF exhaust port.
- ◆ Self relieving.
- ◆ NPTF port threads; ISO G type (parallel) optional
- ◆ Integral pilot regulator porting.
- ◆ 1/4-18 NPTF auxiliary inlet pressure port

**NOTE:**

Pilot (control) regulators (Order separately).

- ◆ General purpose order R56M-2, R350-2 and R67-2
- ◆ Precision applications order ER valve, IR380-2, and R57M-2.

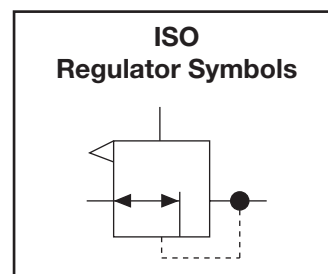

บริษัท ฟลูเทค จำกัด  
FLU-TECH CO.,LTD

845/3-4 หมู่ 3 ถ.เทพารักษ์ ต.เทพารักษ์ อ.เมือง จ.สมุทรปราการ 10270

845/3-4 Thepharak RD., T.Thepharak, A.Muang, Samutprakarn 10270 THAILAND  
Tel. 0 2384 6060, Fax 0 2384 5701, Email : sales@flutech.co.th, www.flutech.co.th

## DIMENSIONS inches (mm)

PORTS	A	B	C	DEPTH †	WEIGHT lb (kg) †
1-1/2	6 (152.4)	3.5 (88.9)	3.7 (94)	5.5 (139.7)	7.15 (3.25)
2	6 (152.4)	3.5 (88.9)	3.7 (94)	5.5 (139.7)	6.87 (3.12)

† Less gauge.

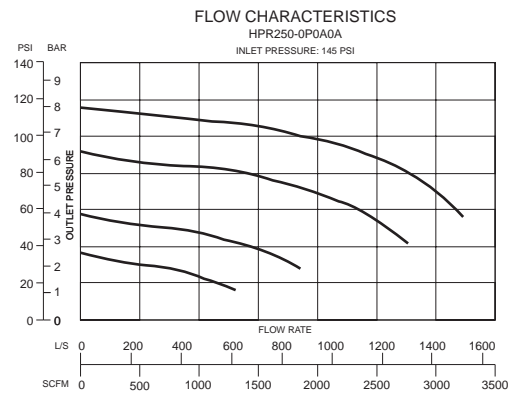
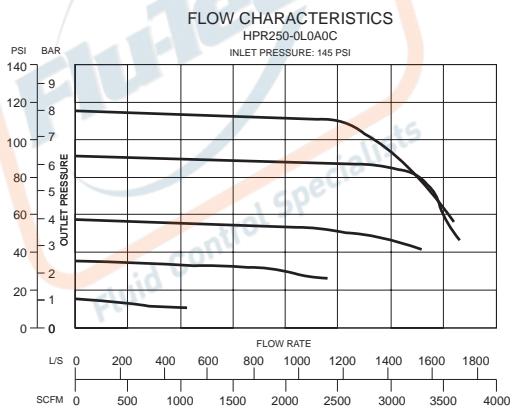
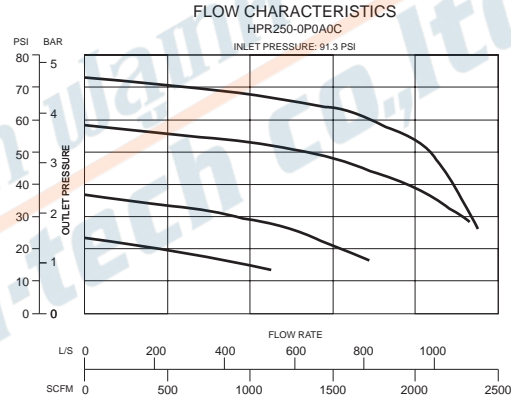
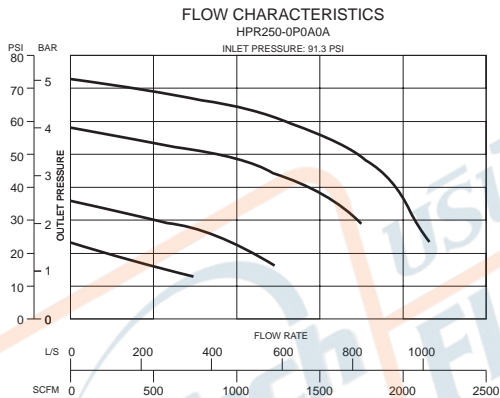
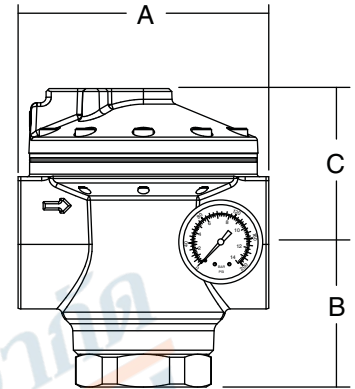

## ORDERING INFORMATION

Change the letters in the sample model number below to specify the regulator you want.

# HPR251 - 12 A G W

### PORT SIZE

1-1/2 NPTF ..... 12  
2 NPTF ..... 16

### OPTIONS

(More than one option can be chosen)

None ..... Leave Blank  
Relieving ..... Leave Blank  
Non-relieving ..... A

### PORT TYPE

NPTF threads ..... Leave Blank  
BSP threads ..... W

### GAUGE OPTION

None ..... Leave Blank  
0-200 PSI Gauge ..... G  
0-300 PSI Gauge ..... G2



**บริษัท ฟลูเทค จำกัด**  
**FLU-TECH CO.,LTD**

845/3-4 หมู่ 3 ถ.เทพารักษ์ ต.เทพารักษ์ อ.เมือง จ.สมุทรปราการ 10270

845/3-4 Thepharak RD., T.Thepharak, A.Muang, Samutprakarn 10270 THAILAND

Tel. 0 2384 6060, Fax 0 2384 5701, Email : sales@flutech.co.th, www.flutech.co.th

# High-relief pilot operated regulator with integral control regulator

## HPR250 Models Port Sizes: 1-1/2, 2



Model Shown: HPR250-0B0B0A

Designed for systems that require high flow, high-relief and pressure regulation. This unit can be installed in an inaccessible location with a control regulator in an accessible location.

- ◆ Diaphragm design. Excellent pressure regulation and stability.
- ◆ High-relief characteristics up to 200 SCFM.
- ◆ Balanced valve minimizes effect of pressure changes on inlet pressure.
- ◆ Inline mounting.
- ◆ 3/4-14 NPTF exhaust port.
- ◆ Self relieving.
- ◆ NPTF port threads; ISO G type (parallel) optional
- ◆ Integral pilot regulator porting.
- ◆ 1/4-18 NPTF auxiliary inlet pressure port



### INTERNAL PILOT REGULATOR OPTION

Constant bleed feature provides quick response to pressure changes .  
Finger adjustment.



### FEED BACK INTEGRAL PILOT REGULATOR OPTION

Provides superior pressure regulation under changing flow demands. Where changes in flow are not sudden or cyclic.



### GENERAL PURPOSE INTEGRAL PILOT REGULATOR OPTION

Provides good pressure regulation, rapid response to changing flow demands, excellent stability.

### WARNING - FEEDBACK REGULATORS

The feedback line must sense the pilot operated regulator outlet pressure and must be connected before turning on the air supply. If it is not connected, the pilot operated regulator outlet pressure will rapidly increase to the inlet pressure when the adjusting knob on the pilot regulator is turned clockwise.



## DIMENSIONS inches (mm)

PORTS	A	B	C	DEPTH †	WEIGHT	WEIGHT	WEIGHT
					lb (kg) †	lb (kg) †	lb (kg) †
1-1/2	6.6 (167.6)	3.5 (88.9)	6.2 (157.4)	5.5 (139.7)	8.70 (3.95) with IR230	8.93 (4.05) with R230	9.13 (4.15) with FB230
2	6.6 (167.6)	3.5 (88.9)	6.2 (157.4)	5.5 (139.7)	8.42 (3.82)	8.65 (3.93)	8.85 (4.05)

† Less gauge.

### SPECIFICATIONS

**Inlet Pressure Range:**

10 PSIG (min) to 450 PSIG (max) (0.7 TO 31 bar)

**Outlet PSI Range:** 0-250 PSI (17.2 bar)

**Operating Temp:** 0°F TO 175°F (-18°C to 79°C)  
(Air moisture content must be dry)

**Flow Rating:** Flow rates exceed 2,000 SCFM.

**Body:** Cast aluminum

**Dome:** Cast aluminum

**Cap:** Teflon coated aluminum

**Valve:** Nitrile bonded aluminum

**Elastomers:** Nitrile

**Ports:** 2" or 1-1/2-NPTF

**Gauge Ports:** 1/4-NPTF

**Exhaust Port:** 3/4-NPTF

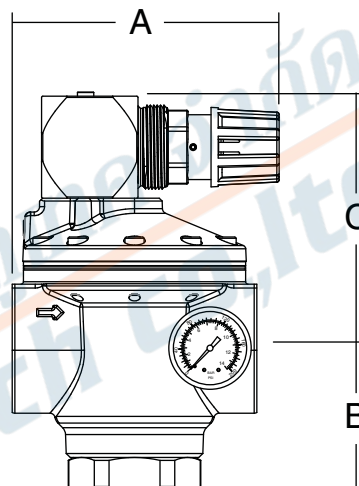

#### ISO SYMBOLS

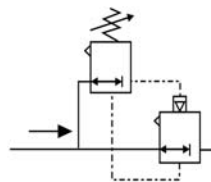

**HPR250 with FEEDBACK**  
Pilot regulator.

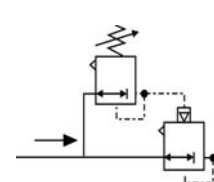

**HPR250 with CONVENTIONAL**  
Pilot regulator.

### ORDERING INFORMATION

Change the letters in the sample model number below to specify the regulator you want.

## HPR250 - 0 A 0 A 0 A - A

**PILOT REGULATOR**

- HPR251 ..... 0
- HPR251-A (non relieving) ..... 1

**CONTROL REGULATOR**

- FB230-Q (feed back) ..... A
- IR230 (internal pilot) ..... B
- R230 (general purpose) ..... C
- R230-Q (contsant bleed) ..... M

**PORT SIZE**

- 1-1/2 NPTF ..... A
- 1-1/2-BSP ..... B
- 2-NPTF ..... C
- 2-BSP ..... D

**EXTERNAL CONNECTION**

- None (used on all products except ... 0  
FB230, feed back controller.
- Copper feed back line tubing ..... 1  
(only use for FB230-Q).

**GAUGE OPTIONS**

- No gauge ..... A
- 0-200 psig (gauge on pilot regulator .. B  
only).
- 0-300 psig (gauge on pilot regulator .. E  
only).



**บริษัท ฟลูเทค จำกัด**  
**FLU-TECH CO.,LTD**

845/3-4 หมู่ 3 ถ.เทพารักษ์ ต.เทพารักษ์ อ.เมือง จ.สมุทรปราการ 10270

845/3-4 Thepharak RD., T.Thepharak, A.Muang, Samutprakarn 10270 THAILAND  
Tel. 0 2384 6060, Fax 0 2384 5701, Email : sales@flutech.co.th, www.flutech.co.th

FLOW CHARACTERISTICS  
HPR250-0P0A0A

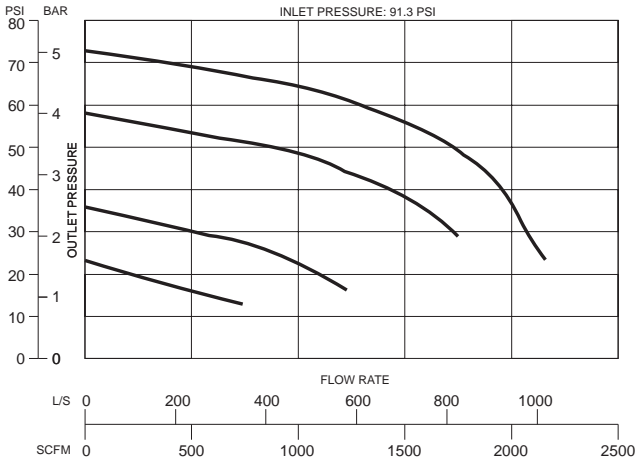

FLOW CHARACTERISTICS  
HPR250-0P0A0C

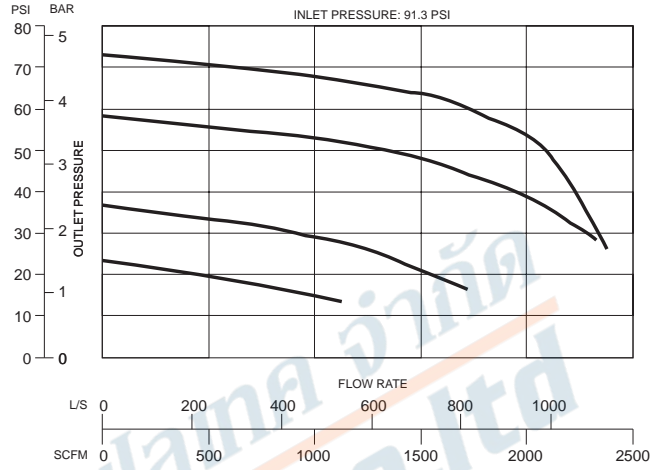

FLOW CHARACTERISTICS  
HPR250-0L0A0C

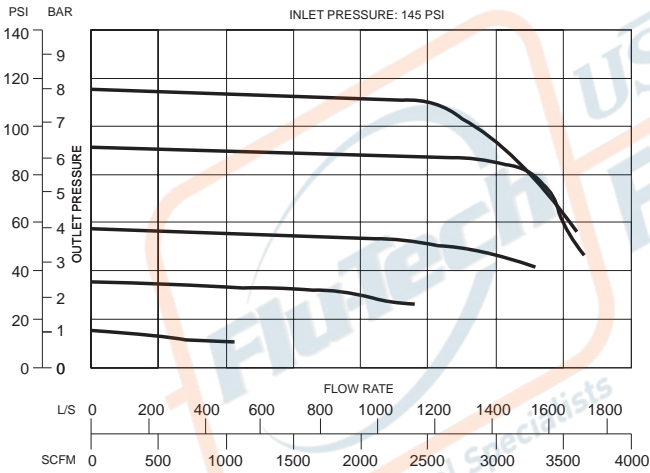

FLOW CHARACTERISTICS  
HPR250-0P0A0A

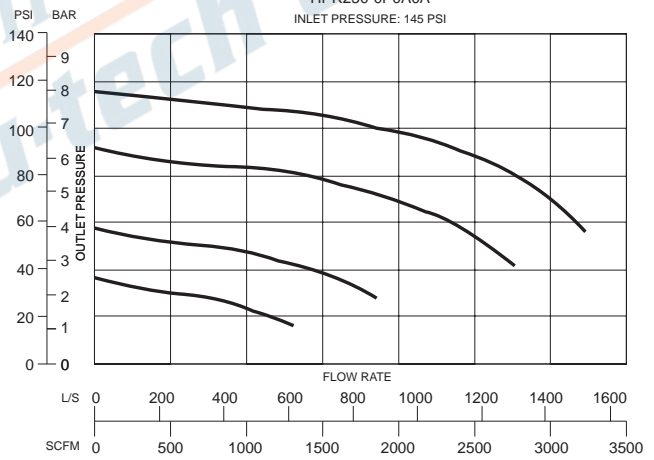

SEAL KIT	DESCRIPTION
A250-44	<b>SEAL KIT:</b> inclusive for HPR251 pilot operated regulator and all its pilot (control regulators. Includes all o-rings/seals, breather filter and screen. Ther may be un-used parts in kit depending on which pilot model is being serviced.
A251-91	<b>SEAL KIT:</b> applies only to the <b>HPR251</b> . Includes diaphragm assembly and 2 o-rings.
A250-40	<b>SEAL KIT:</b> applies only to <b>HPR250</b> . Includes all o-rings/seals and screen for both pilot and pilot operated regulators.

DIAPHRAGM KITS	DESCRIPTION
A251-71	<b>HPR251 DIAPHRAGM KIT.</b> Includes diaphragm assembly and 2 o-rings.
A230-51	<b>R230-*Q and IR230 diaphragm kit.</b> Includes diaphragm assembly and 1 o-ring.
A230-52	<b>R230 and FB230 diaphragm kit.</b> Includes diaphragm assembly and 1 o-ring.

VALVE KITS	DESCRIPTION
A251-81	<b>HPR251 valve kit.</b> Includes valve, valve spring, washer, retaining ring and 2 o-rings.
A230-63	<b>R230, R230-*Q and IR230 valve kit.</b> Includes valve, valve spring and 2 o-rings.
A230-64	<b>FB230 valve kit.</b> Includes valve with bleed, valve spring and 2 o-rings.

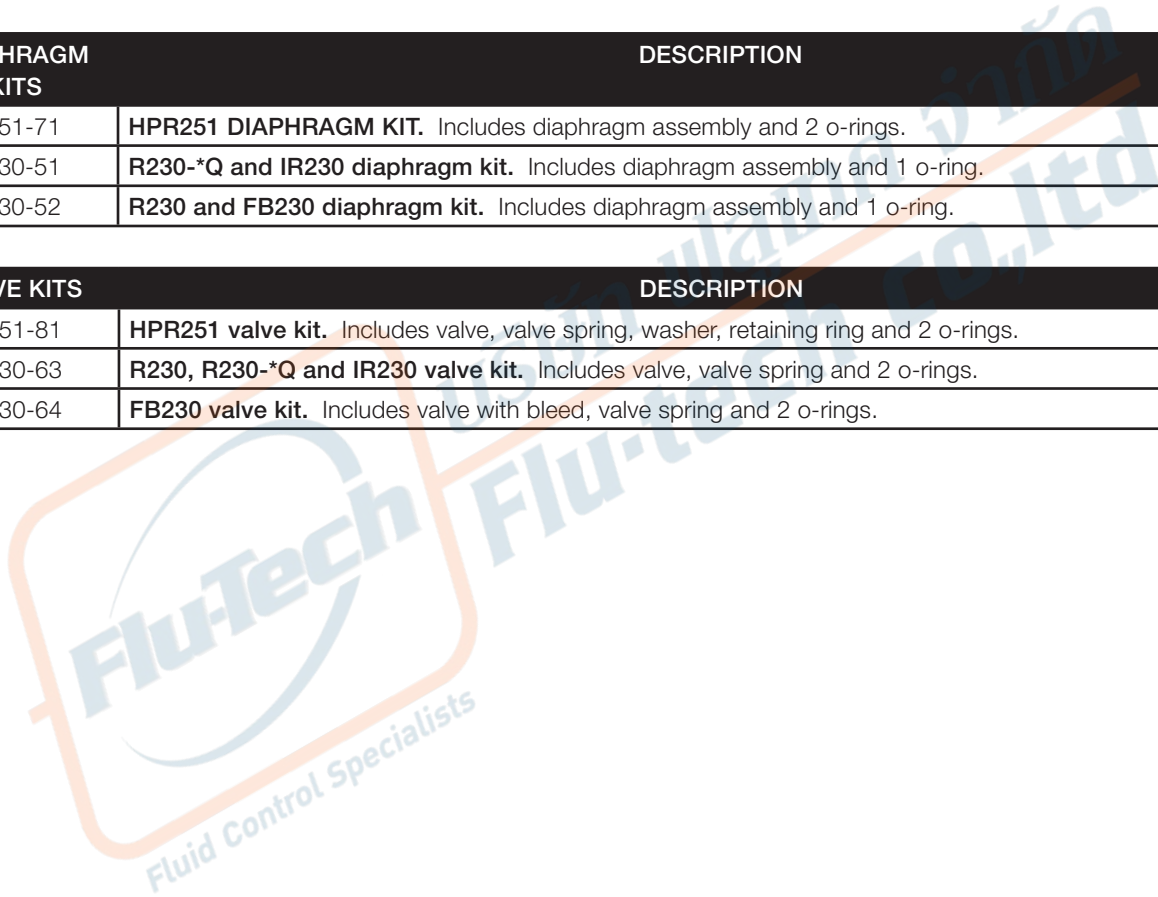

# High-Flow VANGUARD Externally Piloted Regulators

## PR300 Models Port Sizes: 3



Model Shown: PR300-24G

- ◆ Inline mounting.
- ◆ Piston-type design.
- ◆ Self-relieving.
- ◆ Pressure gauge.
- ◆ Optional remote sensing.
- ◆ Aluminum body and dome.
- ◆ Flow rates exceeding 4,000 SCFM
- ◆ NPTF port threads; optional BSPP threads.

**Note:** Pilot (control) regulators (order separately).

- ◆ General purpose applications order R56M-2, R60-2, R67-2, R100-2, or R380-3
- ◆ Precision applications order IR100-2, R57M-2, IR380-3 or ER valve

### SPECIFICATIONS

**Ambient/Media Temperature:**

40° to 175°F (4° to 79°C).

**Body and Dome:** Aluminum.

**Fluid Media:** Compressed air.

**Inlet Pressure:** 300 psig (21 bar) maximum.

**Outlet Pressure:** 0 to 200 psig (0 to 14 bar).

**NOTE:** Outlet pressure depends on the selection of the control regulator.

**Pilot Ports:** 1/4 NPTF.

**Pressure Gauge:** 0 to 200 psig (14 bar); 1/4 NPT gauge ports front and rear.

**Seals:** Nitrile, Optional Viton

**Valve:** Aluminum.

**Valve Cap:** Aluminum.

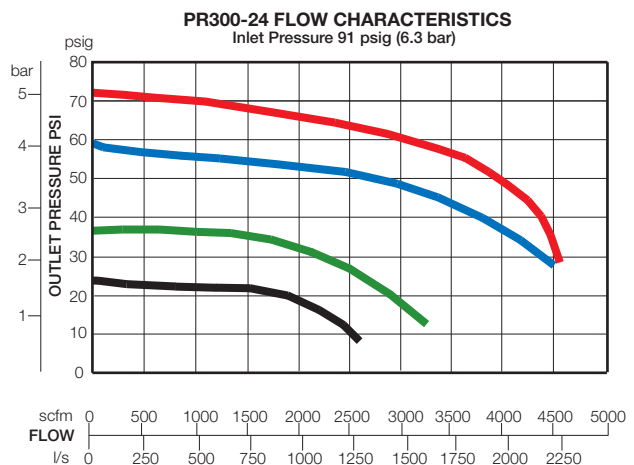

บริษัท ฟลูเทค จำกัด  
FLU-TECH CO.,LTD

845/3-4 หมู่ 3 ถ.เทพารักษ์ ต.เทพารักษ์ อ.เมือง จ.สมุทรปราการ 10270

845/3-4 Thepharak RD., T.Thepharak, A.Muang, Samutprakarn 10270 THAILAND

Tel. 0 2384 6060, Fax 0 2384 5701, Email : sales@flutech.co.th, www.flutech.co.th

## DIMENSIONS inches (mm)

A	B	C	Depth †	Weight † lb (kg)
8.40 (214)	7.36 (187)	3.74 (95)	8.00 (203)	21.7 (9.88)

† Less gauge.

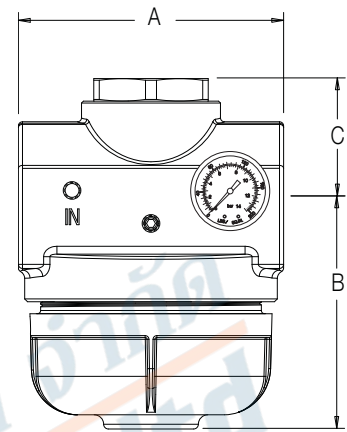

## ORDERING INFORMATION

Change the letters in the sample model number below to specify the regulator you want.

**NOTE:** Order a control regulator such as R55M, R56M, R57M, R100, R380, IR100, or IR380 separately.

**PR30 0 - 24 A G W**

### REGULATOR TYPE

- Standard Regulator .....0
- Remote Sensing Regulator .....1
- Standard Regulator with .....2  
internal Bias spring and gauge  
port plugged.
- Remote Sensing Regulator .....3  
with internal Bias spring and  
gauge port plugged.

### PORT SIZE

- 3 NPTF .....24

### OPTIONS

- Relieving .....Leave Blank
- Non-relieving .....A
- Constant bleed .....Q  
**Option '0' must be chosen  
under REGULATOR TYPE.**
- Viton Seals .....V

### PORT TYPE

- NPTF threads ..... Leave Blank
- BSPP threads ..... W

### GAUGE OPTION

- None ..... Leave Blank
- 0-200 PSI Gauge ..... G



**บริษัท ฟลูเทค จำกัด**  
**FLU-TECH CO.,LTD**

845/3-4 หมู่ 3 ถ.เทพารักษ์ ต.เทพารักษ์ อ.เมือง จ.สมุทรปราการ 10270

845/3-4 Thepharak RD., T.Thepharak, A.Muang, Samutprakarn 10270 THAILAND

Tel. 0 2384 6060, Fax 0 2384 5701, Email : sales@flutech.co.th, www.flutech.co.th