









Flow rate controller for gases

- Reliable and automated flow control on site
- Stable control of the set point, independent on pressure fluctuations
- Programmable alarm functions (pressure monitoring)
- Simple start-up by manual setpoint setting and display
- Leakage air compensation programmable for dense phase conveying systems

Product variants described in the data sheet may differ from the product presentation and description.

Can be combined with

	Type 6281 Servo-assisted 2/2 way diaphragm valve	▶
	Type 2100 Pneumatically operated 2/2-way angle seat valve ELEMENT for decentralized automation	▶
	Type 8805 Ball valve / Butterfly valve with pneumatic rotary actuator	▶
	Type 8653 AirLINE Field - the valve island optimised for process automation	▶
	Type 8746 Mass flow controller (MFC) / Mass flow meter (MFM) for gases	▶
	Type 8400 Screw-in temperature threshold detector/transmitter with display	▶

Type description

The flow rate controller type 8750 represents a closed flow control loop to measure and control gases using the differential pressure principle. The reliable and robust system consists of an ELEMENT control valve, type 2301, the compact process controller type 8693 put on top of the valve and two pressure transmitters, type 8325. The Bürkert flow rate controller does not need a separate flow meter. The valve seat serves as variable orifice. From the pressure difference across the valve and the given density and temperature a volume flow, referring to the conditions programmed, can be calculated. For that the process controller uses the flow characteristics of the valve and the scales of the pressure transmitters programmed. The volume flow set can then be adjusted by changing the stroke of the control valve. The flow rate controller offers a high repeatability and large measuring range. Beneficial is that the control itself is used for both, controlling the flow and measuring over an orifice. With the variable orifice of the control valve the measurement range is increased significantly. Low assembly costs and easy commissioning are further advantages of this unique product.

DTS 1000089368 EN Version: M Status: RL (released | freigegeben | valide) printed: 02.11.2021

Table of contents

1. General technical data	3
2. Materials	4
2.1. Chemical Resistance Chart – Bürkert resistApp.....	4
2.2. Material specifications.....	4
ELEMENT version, actuator M (70 mm), N (90 mm), P (130 mm).....	4
CLASSIC version, actuator L (225 mm).....	5
Standard pressure transmitter.....	5
3. Approvals	5
4. Dimensions	6
4.1. Overall device.....	6
4.2. Connection flange.....	7
5. Performance specifications	8
5.1. Fluidic data.....	8
Flow characteristics of the control valve Type 2301.....	8
Overview of fluidic data for flow under seat.....	8
6. Product operation	9
6.1. Flow measurement principle.....	9
7. Product installation	9
7.1. Piping upstream of the fluid flow regulator.....	9
7.2. Electrical connections.....	10
PROFIBUS DP.....	11
8. Ordering information	11
8.1. Bürkert eShop – Easy ordering and quick delivery.....	11
8.2. Recommendation regarding product selection.....	12
8.3. Bürkert product filter.....	12
8.4. Ordering chart for flange.....	12
8.5. Ordering chart accessories.....	13

1. General technical data

Product properties	
Dimensions	Detailed information can be found in chapter "4. Dimensions" on page 6.
Materials	Detailed information can be found in chapter "2. Materials" on page 4.
Design	Globe control valve with integrated flow measurement and control
Nominal diameter	DN 15...DN 100
Port connection	Flange according to DIN EN 1092 - 1, ANSI B 16.5 or JIS 10K
Safety setting in case of power failure	Closed (Control function A)
Flow direction	Against closing direction (under seat)
Performance data	
Operating pressure	Valve: 0 bar(g)...16 bar(g)
Nominal pressure (max.)	PN 25 (DIN EN 1333), Class 150 (DIN EN 1759)
Pilot pressure	5.5...7 bar (actuator M, N, P, see "ELEMENT version, actuator M (70 mm), N (90 mm), P (130 mm)" on page 4) 5...6 bar (actuator L, see "CLASSIC version, actuator L (225 mm)" on page 5) Optional on request: version for reduced control pressure from 3.5 bar
Seat leakage acc. to DIN EN 60534 - 4	Leakage class VI for PTFE (soft sealing)
K _{vs} values	2.1 m ³ /h...140 m ³ /h, see "5.1. Fluidic data" on page 8
Operating characteristic	Linear or equal percentage
Theoretical range ability	Up to 50:1
Flow rate measurement	
Measured variable	Volume flow, reference conditions programmable
Measuring principle	Differential pressure via orifice plate and pressure transmitter on the inlet and outlet side of the orifice plate
Pressure measurement ranges	0...100 mbar to 0...16 bar
Pressure measuring principle	Piezoresistive
Pressure measuring error	≤0.5% of full scale
Electrical data	
Operating voltage	24 V DC ± 10%
Max. residual ripple	10%
Electrical connection	Operating voltage: circular connector M12x1, 4 pin Analogue input/output signals (for setpoint and actual value): circular connector M12x1, 8 pin Additionally for Bus communication: M12x1, 5 pin Internal signals (for connecting the pressure transmitters): circular connector M8x1, 4 pin
Communication/signal interface	Analogue (4...20 mA, 0...10 V) or digital (PROFIBUS DP)
Medium data	
Medium	Air, oxygen, nitrogen, carbon dioxide, neutral gases, fuel gases
Medium temperature	-10...80 °C
Control medium	Air or neutral gases acc. to DIN ISO 8573 - 1: dust Cl. 7 (<40 µm), particle density Cl. 5 (<10 mg/m ³), pressure dew point Cl. 3 (≤20 °C), oil conc. Cl. X (<25 mg/m ³)
Process/Port connection & communication	
Pilot air ports	Threaded connection G 1/8, stainless steel
Approvals and certificates	
Approval	Explosion protection: ATEX for zone 3G on request
Conformity	Materials in contact with medium conform to EG1935/2004 and FDA Oxygen conformity for DN 15 (up to +60 °C) on request Fuel gases (seals according to EN549)
Certificate	2.2 or 3.1 certificate on request
Environment and installation	
Ambient temperature	0...55 °C
Degree of protection	IP65 / IP67 acc. to EN 60529

2. Materials

2.1. Chemical Resistance Chart – Bürkert resistApp



Bürkert resistApp – Chemical Resistance Chart

You want to ensure the reliability and durability of the materials in your individual application case? Verify your combination of media and materials on our website or in our resistApp.

[Start Chemical Resistance Check](#)

2.2. Material specifications

ELEMENT version, actuator M (70 mm), N (90 mm), P (130 mm)

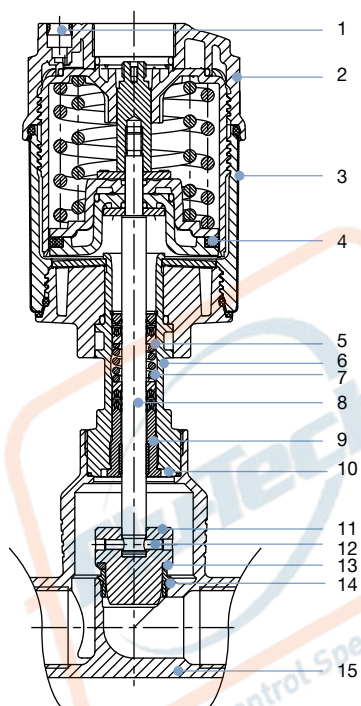

No.	Element	Material
1	Pilot air ports	Push-in connector PP
2	Actuator	PPS
3	Cover	Stainless steel 1.4561 (316Ti)
4	Piston seal	FKM
5	Spring	Stainless steel 1.4310
6	Pipe	Stainless steel 1.4401 (316)
7	Spindle sealing	PTFE V-Rings (filled), with spring compensation
8	Spindle	Stainless steel 1.4401 (316)/1.4404 (316L)
9	Spindle guide	Stainless steel 1.4404 (316L), PTFE filled
10	Body seal	Graphite or PTFE
11	Control cone	Stainless steel 1.4571
12	Spring straight pin	Stainless steel 1.4310
13	Seat seal	PTFE
14	Valve seat with O-Ring	Stainless steel 1.4571, EPDM
15	Valve body	Stainless steel CF3M (316L)
-	Pipe for inlet and outlet section ^{1.)}	Stainless steel 1.4404 / 1.4435
-	Pressure sensor sleeve ^{1.)}	Stainless steel 1.4404
-	Connection flange ^{1.)}	Stainless steel 1.4404 (316L)

1.) Not shown in the drawing.

DTS 1000089368 EN Version: M Status: RL (released | freigegeben | validé) printed: 02.11.2021

CLASSIC version, actuator L (225 mm)

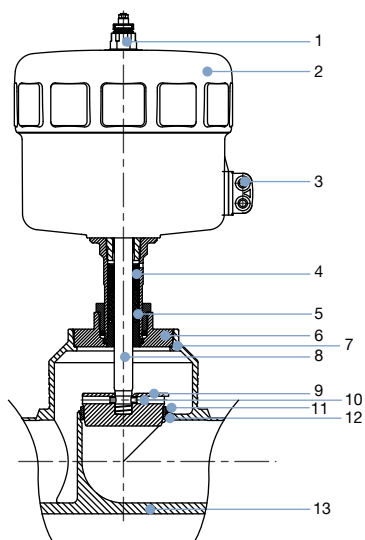

No.	Element	Material
1	Adapter	Stainless steel 1.4305
2	Actuator	Polyamide (PA)
3	Pilot air ports	Stainless steel 1.4305
4	Spindle sealing	PTFE V-Rings (filled), with spring compensation
5	Spring	Stainless steel 1.4568
6	Nipple	Stainless steel 1.4404
7	Body seal	Graphite or PTFE
8	Spindle	Stainless steel 1.4404
9	Control cone	Stainless steel 1.4571
10	Spring straight pin	Stainless steel 1.4310
11	Seat seal	PTFE
12	Valve seat with O-Ring	Stainless steel 1.4571, EPDM
13	Valve body	Stainless steel CF3M (316L)
-	Pipe for inlet and outlet section ^{1.)}	Stainless steel 1.4404 / 1.4435
-	Pressure sensor sleeve ^{1.)}	Stainless steel 1.4404
-	Connection flange ^{1.)}	Stainless steel 1.4404 (316L)

1.) Not shown in the drawing.

Standard pressure transmitter

Description	Material
Non-wetted parts	
Body standard version	Stainless steel 1.4571 (316Ti)
Wetted parts	
Standard version < 0.4 bar	Stainless steel 1.4571 (316Ti)
Standard version ≥ 0.4 bar	Stainless steel 1.4404 (316L) (for ≤ 10 bar) Stainless steel 1.4534 (13-8 PH) (for > 10 bar)
Flush diaphragm version (standard)	Stainless steel 1.4571 (316Ti), FKM seal

3. Approvals

Note:

All approvals or conformities are not included in a standard unit and must be requested separately.

Approval	Description
	Conformity of all materials in contact with the medium EC regulation 1935/2004 FDA – Code of Federal Regulations Title 21 Paragraph 177 (CFR 21 177.2600)
	Oxygen Suitable for use with gaseous oxygen for medium temperature up to 60 °C and operating pressure up to 16 bar(g) (option), manufacturer's declaration possible for DN 15
	Explosion proof Ex-marking of the components according to the following table
	Fuel gases Valve seals conform to EN549 (elastomers for gas appliances), suitable for medium temperature 0 °C...60 °C, ambient temperature - 10...60 °C and operating pressures 0...16 bar(g) (option)

Unit	Ex marking of the component
Valve Type 2301	EPS 18 ATEX 2 008 X / IECEx EPS 18.0007 X mech. Ex h IIC T4 Gb / Ex h IIIC T135 °C Db
Control unit Type 8693	ATEX II 3G Ex ec IIC T4 Gc, II 3D Ex tc IIIC T135° Dc
Pressure transmitter	IECEx + ATEX II 3G Ex nA IIC T4/T5/T6 Gc X, II 3D Ex tc IIIC T90 °C Dc
Cable sockets for pressure transmitter connection on the control unit	ATEX II 2G Ex eb IIC T5 Gb

Visit product website ▶



4. Dimensions

4.1. Overall device

Note:

Dimensions in mm

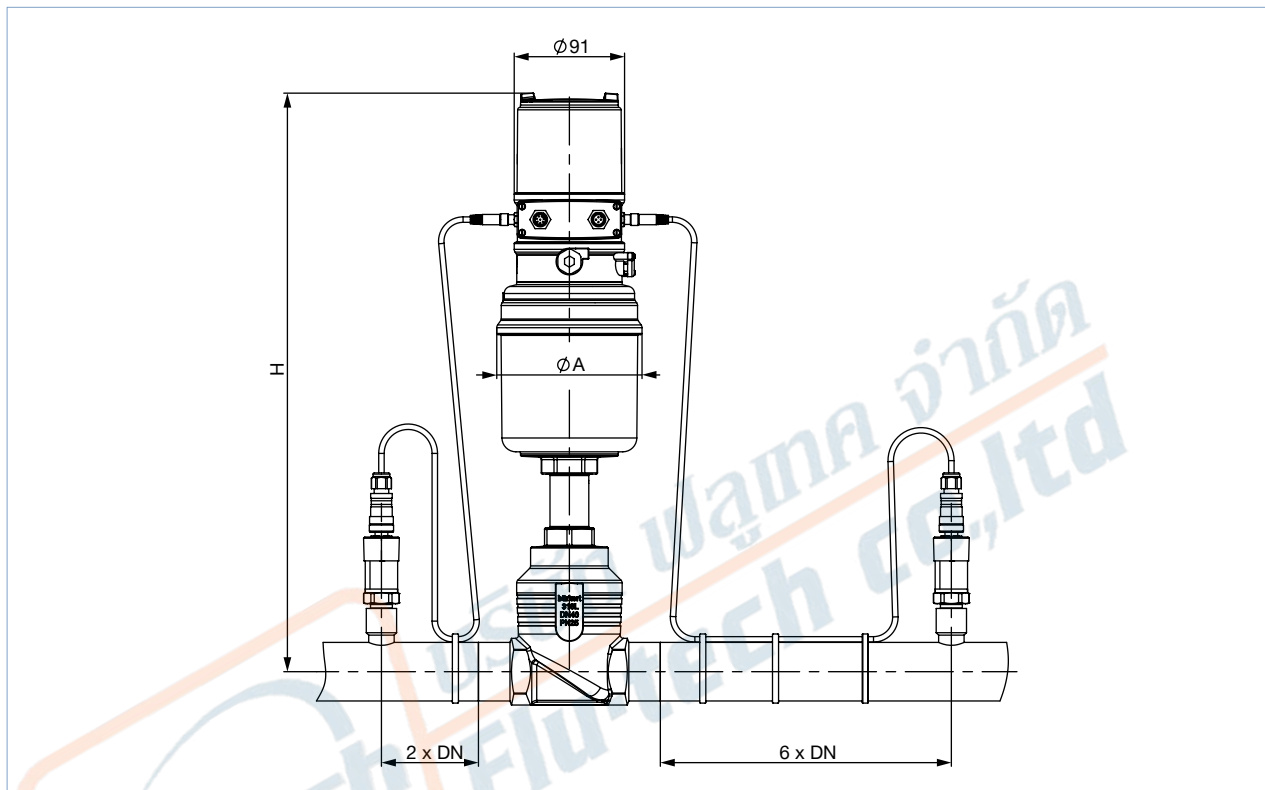

DN (pipe connection)	Actuator size	Ø A	H
		[mm]	[mm]
15	Ø70 (M) ELEMENT	91	383
25	Ø70 (M) ELEMENT	91	392
40	Ø90 (N) ELEMENT	120	478
50	Ø130 (P) ELEMENT	159	536
65	Ø130 (P) ELEMENT	159	590
80	Ø130 (P) ELEMENT	159	598
100	Ø225 (L) CLASSIC	261	640
	Ø130 (P) ELEMENT	159	608
	Ø225 (L) CLASSIC	261	650

4.2. Connection flange

Note:

Dimensions in mm

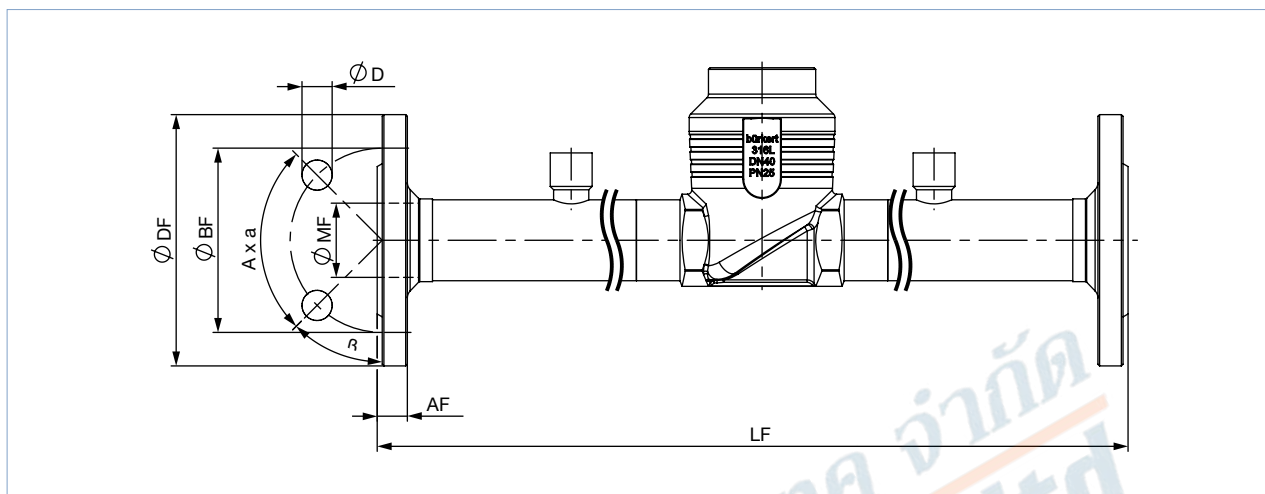

Nominal diameter (pipe)	DIN EN 1092 PN 25							JIS 10K							
	DN	Ø DF	LF	Ø BF	AF	Ø D	A x α	Ø MF	Ø DF	LF	Ø BF	AF	Ø D	A x α	Ø MF
15	95	300	65	16	14	14	4 x 90°	18.1	95	300	70	12	15	4 x 90°	18.1
25	115	500	85	18	14	14	4 x 90°	29.7	125	500	90	14	19	4 x 90°	29.7
40	150	700	110	18	18	18	4 x 90°	44.3	140	700	105	16	19	4 x 90°	44.3
50	165	800	125	20	18	18	4 x 90°	56.3	155	800	120	16	19	4 x 90°	56.3
65	185	1000	145	22	18	18	8 x 45°	66.0	175	1000	140	18	19	4 x 90°	71.5
80	200	1200	160	24	18	18	8 x 45°	81.0	185	1200	150	18	19	8 x 45°	84.3
100	235	1400	190	24	22	22	8 x 45°	100.0	292	1400	175	18	19	8 x 45°	109.1

Nominal diameter (pipe)	ANSI B 16.5 Class 150							
	NPS	Ø DF	LF	Ø BF	AF	Ø D	A x α	Ø MF
½" (DN 15)	89	300	60.5	11.2	15.7	15.7	4 x 90°	15.7
1" (DN 25)	108	500	79.2	14.2	15.7	15.7	4 x 90°	26.7
1½" (DN 40)	127	700	98.6	17.5	15.7	15.7	4 x 90°	40.9
2" (DN 50)	152	800	120.7	19.1	19.1	19.1	4 x 90°	52.6
2½" (DN 65)	178	1000	139.7	22.3	19.1	19.1	4 x 90°	62.7
3" (DN 80)	190	1200	152.5	23.9	19.1	19.1	4 x 90°	78.0
4" (DN 100)	229	1400	190.5	23.9	19.1	19.1	8 x 45°	102.4

5. Performance specifications

5.1. Fluidic data

Flow characteristics of the control valve Type 2301

- K_v value [m^3/h] and flow characteristic according to DIN EN 60534-2-4
- K_{vs} shows the maximum adjustable flow capacity of a control valve series. The K_v value [m^3/h] is measured in accordance with DIN EN 60534-2-3 with water (5...40 °C) and a pressure drop of 1 bar across the valve.

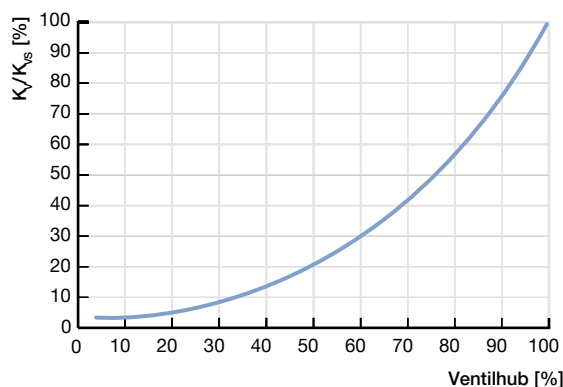

Equal percentage characteristics - detailed K_v values see below.

Overview of fluidic data for flow under seat

Note:

We will be happy to design the appropriate valve size of the fluid quantity regulator for you. Please provide us with your valve design data using the last page of this data sheet.

Nominal diameter (pipe)		Seat size	Actuator size	K_v value at stroke [m^3/h]						K_{vs} value [m^3/h]
DN	NPS			5%	10%	30%	50%	70%	90%	
15	½"	8	70 (M)	–	0.080	0.13	0.27	0.63	1.6	2.1
		10	70 (M)	–	0.11	0.19	0.49	1.1	2.5	3.1
		15	70 (M)	0.14	0.17	0.35	0.80	1.8	3.7	4.3
25	1"	15	70 (M)	0.14	0.17	0.35	0.80	1.8	4.1	5.3
		20	70 (M)	0.20	0.25	0.47	1.1	2.5	5.4	7.2
		25	70 (M)	0.35	0.38	1.0	2.2	5.1	9.4	12.0
40	1½"	25	90 (N)	0.38	0.48	0.95	1.9	3.7	7.2	9.4
		32	90 (N)	0.45	0.55	1.1	2.5	5.0	10.8	14.4
		40	90 (N)	0.55	0.67	1.5	3.2	6.5	13.6	17.5
50	2"	32	130 (P)	0.48	0.60	1.3	3.2	6.9	16.0	21.0
		40	130 (P)	0.60	0.70	1.7	4.0	9.2	18.9	24.5
		50	130 (P)	0.90	1.1	2.9	6.8	15.5	29.5	37.0
65	2½"	40	130 (P)	0.65	0.75	1.8	4.3	10.4	22.0	29.0
		50	130 (P)	1.0	1.2	3.1	6.7	16.0	35.0	45.0
		65	130 (P)	1.6	2.0	5.0	13.5	33.0	56	65.0

Nominal diameter (pipe)		Seat size	Actuator size	K _v value at stroke [m ³ /h]						K _{vs} value [m ³ /h]
DN	NPS			5%	10%	30%	50%	70%	90%	
80	3"	50	130 (P)	1.0	1.2	3.4	8.3	19.0	35.0	45.0
		65	130 (P)	1.6	2.0	5.0	13.0	35.0	61	73
			225 (L)	1.4	1.7	3.8	8.2	19.5	50	70
		80	130 (P)	2.5	3.4	10.7	27.0	58	87	100
			225 (L)	2.1	2.6	7.0	16.0	40.0	83	100
100	4"	65	130 (P)	1.4	1.8	5.0	15.0	37.0	64	77
			225 (L)	1.4	1.7	3.8	8.3	20.0	51	75
		80	130 (P)	2.2	3.1	10.3	30.0	66	97	110
			225 (L)	2.1	2.6	7.0	17.0	44.0	89	115
		100	130 (P)	3.8	5.2	15.0	46.5	90	128	140
			225 (L)	3.2	3.9	9.0	20.5	51	118	140

6. Product operation

6.1. Flow measurement principle

The valve seat of the control valve represents a variable orifice. By measuring the pressure upstream and downstream of this orifice and a programmed flow characteristic of the corresponding valve, the current flow rate can be determined. This is compared with the flow setpoint transmitted to the unit. In the event of a control deviation, the valve and thus the orifice are adjusted exactly so that the setpoint and actual value match. To determine the flow rate, the density of the gas and the reference conditions, among other things, must be set in the controller during commissioning. The temperature of gas that is usually present is also permanently programmed in. The control parameters of the PI controller must also be determined and set during commissioning. If the outlet pressure fluctuates, the unit automatically reacts to this by detecting a control deviation between the setpoint and actual value and adjusting the valve so that this disappears.

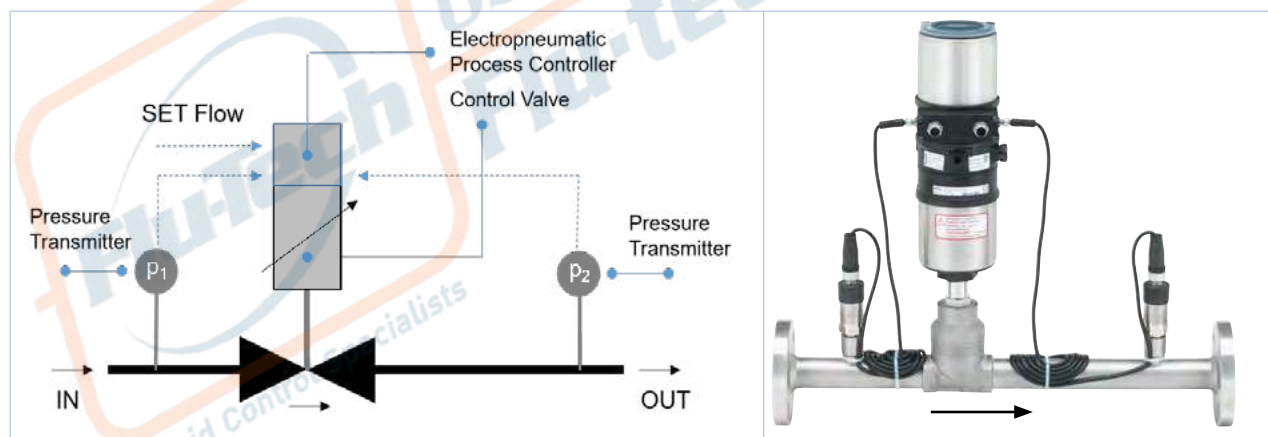

7. Product installation

7.1. Piping upstream of the fluid flow regulator

For high accuracy, the inlet distances upstream of the fluid quantity regulator must be observed in accordance with EN ISO 5167 - 1. The outlet section downstream of the valve is already integrated in the system. Depending on the installation situation, an inlet distance corresponding to 15...20 times the pipe diameter is recommended.

7.2. Electrical connections

Multipole connection

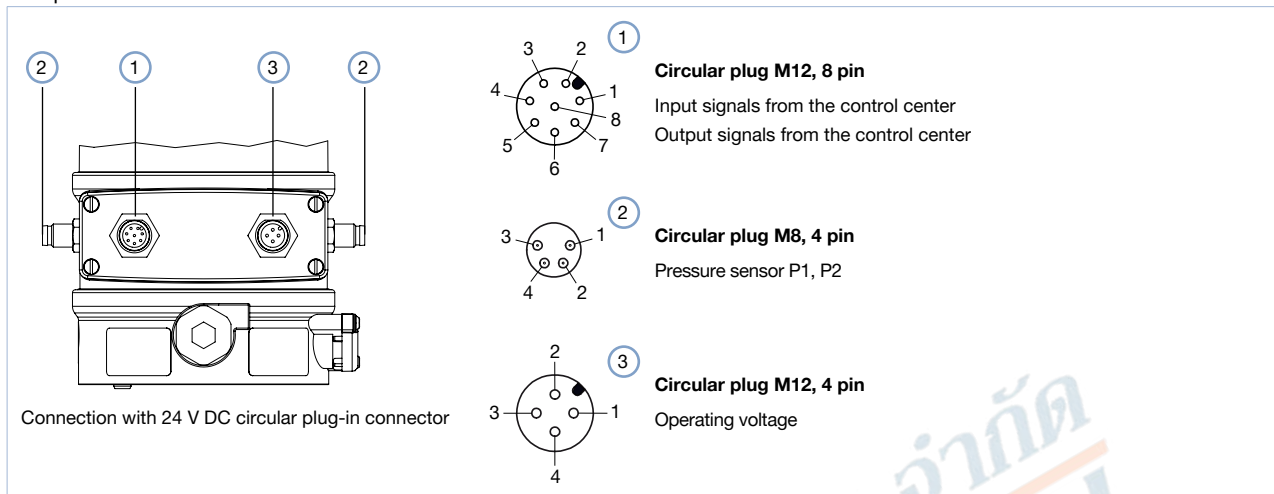

Circular plug M12, 8 pin		
Pin	Wire colour ^{1.)}	Assignment
Set-point value, digital input		
8	Red	Set-point value + (0/4...20 mA / 0...5/10 V)
7	Blue	Set-point value GND
1	White	Digital input +
Input/output signals		
6	Pink	Analogue position feedback +
5	Grey	Analogue position feedback GND
4	Yellow	Digital output 1
3	Green	Digital output 2
2	Brown	Digital outputs GND

1.) The colours indicated refer to the connection cable (919267) available as an accessory.

Circular plug M8, 4 pin (pressure sensor)		
Pin	Wire colour	Assignment
Set-point value, digital input		
1	Brown	+24 V pressure sensor power supply
2	White	4...20 mA output from pressure sensor

Circular plug M12, 4 pin (operating voltage)		
Pin	Wire colour ^{1.)}	Assignment
Set-point value, digital input		
1	Brown	Operating voltage +24 V DC
3	Blue	Operating voltage GND

1.) The colours indicated refer to the connection cable (919267) available as an accessory.

DTS 1000089368 EN Version: M Status: RL (released | freigegeben | valide) printed: 02.11.2021

PROFIBUS DP

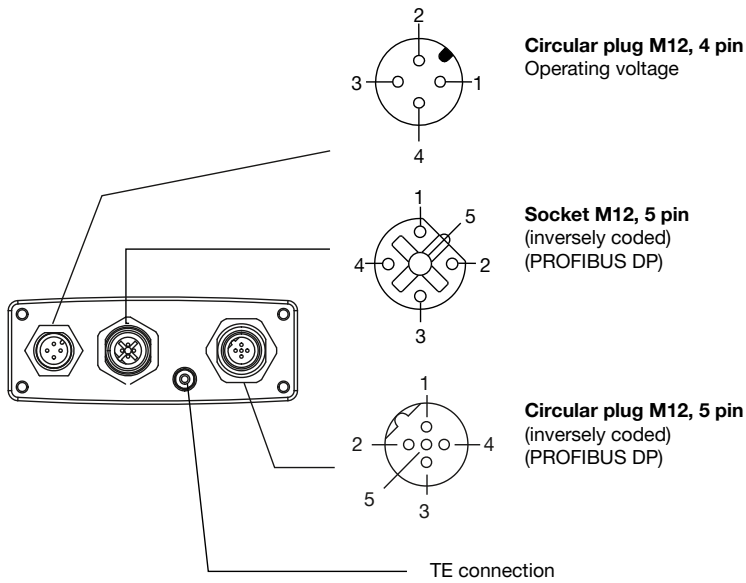

Socket/circular plug M12, 5 pin - Fieldbus connection

Pin	Configuration
1	VP+5
2	RxD/TxD-N
3	DGND
4	RxD/TxD-P
5	Not connected
Thread	Shield/protective earth

Circular plug M12, 4 pin - operating voltage

Pin	Wire colour ^{1.)}	Configuration
1	Brown	+24 V
3	Blue	GND

1.) The wire colours indicated refer to the connection cable available as an accessory with the Article no. 918038.

8. Ordering information

8.1. Bürkert eShop – Easy ordering and quick delivery



Bürkert eShop – Easy ordering and fast delivery

You want to find your desired Bürkert product or spare part quickly and order directly? Our online shop is available for you 24/7. Sign up and enjoy all the benefits.

[Order online now](#)

8.2. Recommendation regarding product selection

Note:

For optimal sizing of the actuator in the fluid quantity regulator (nominal valve size), the pressure values immediately upstream and downstream of the fluid quantity regulator (p_1 , p_2) at this flow rate Q_{Nom} should be known in addition to the required maximum flow rate Q_{Nom} . These are generally not identical with the inlet and outlet pressure of the entire system, because additional flow resistances (pipes, additional shut-off valves, nozzles, etc.) are usually present both upstream and downstream of the fluid quantity regulator. In the **product questionnaire form** at the end of the document, the pressure values, immediately upstream and downstream of the fluid volume regulator, must always be stated. If these are not known or accessible by measurement, an estimation, taking into account the approximate pressure drops across the flow resistances upstream and downstream of the fluid quantity regulator at Q_{Nom} , is necessary. The specification of the maximum expected inlet pressure $p_{1, max}$ is necessary to ensure the tight-closing function of the actuator in all operating conditions.

8.3. Bürkert product filter



Bürkert product filter – Get quickly to the right product

You want to select products comfortably based on your technical requirements? Use the Bürkert product filter and find suitable articles for your application quickly and easily.

[Try out our product filter](#)

8.4. Ordering chart for flange

Note:

- Flange acc. to DIN EN 1092-1 with PTFE valve seat seal
- For the design of the fluid flow controller, please request advice. Please contact your local sales centre. Please also use the **product enquiry form** at the end of this data sheet.

Connection and seat size	Actuator size	K _{vs} value [m ³ /h]	Pressure range [bar(ü)]	Air volume ^{1.)} at p ₁ = 6 and p ₂ = 3 bar(g)		Article no.
				Q _{max} [Nm ³ /h]	Q _{min} [Nm ³ /h]	
DN 15	M (70 mm)	4.3	0...10	350	20	280436 ☒
DN 25	M (70 mm)	12.0	0...10	900	40	280437 ☒
DN 40	N (90 mm)	17.5	0...10	1300	70	280438 ☒
DN 50	P (130 mm)	37.0	0...10	2900	120	280439 ☒
DN 65	P (130 mm)	65.0	0...10	5500	200	280440 ☒
DN 80	P (130 mm)	100	0...10	8500	350	280441 ☒
DN 100	P (130 mm)	140	0...6	12000	500	280442 ☒

1.) For reference, the air volume ranges are listed at a typical inlet pressure of 6 bar(g). The values refer to air at a temperature of 20 °C. The ranges apply to the valve position range of 10 %...90 %.

Further versions on request



Additional

- Specific pressure ranges
- Alternative seat seals
- Reduced control pressure from 3.5 bar

8.5. Ordering chart accessories

Note:

Spare parts for the valve seat and control cone can be ordered in the form of spare parts sets. Please refer to the operating instructions for the appropriate Article no.

Description	Article no.
M12 socket, 8 pin with 5 m cable	919267 
M12 socket, 4 pin with 5 m cable	918038 
Communication adapter for connection to a computer, incl. extension cable	227093 
Silencer G 1/8 for the control air outlet	780779 