



Mass flow controller for gases (MFC)

- Nominal flow ranges from 20 l/min up to 1500 l/min
- High measuring accuracy and repeatability
- Fast settling times
- Protection class IP65
- Optional: Fieldbus interface

Product variants described in the data sheet may differ from the product presentation and description.

Can be combined with



Type 0330

Direct-acting 2/2 or 3/2-way pivoted armature valve



Type 6027

Direct-acting 2/2 way plunger valve

Type description

The mass flow controller (MFC) Type 8626 is suitable for controlling the mass flow of high gas quantities. The thermal inline sensor is located directly in the gas stream and therefore achieves very fast response times. A direct-acting proportional valve from Bürkert guarantees, as the actuator, high response sensitivity. The integrated PI controller ensures excellent control characteristics of the MFC. The 8626 can optionally be calibrated for two different gases; the user can toggle between these two gases. As electrical interfaces both, analogue standard signals and fieldbuses are available. The mass flow controller Type 8626 is especially designed for use in harsh environments due to a low sensitivity to contamination and the high IP protection class. The MFC is ideal for various applications, e.g. burner controls, heat treatment, metallurgy, the food and beverage industry, environmental technology, material coatings, fuel cell technology or test benches.

Table of contents

1. General technical data	3
2. Materials	4
2.1. Chemical Resistance Chart – Bürkert resistApp.....	4
3. Dimensions	5
3.1. MFC 8626 with valve type 2873 (9 W coil)	5
3.2. MFC 8626 with valve type 2873 (9 W coil) and base block for large nominal flow rates	5
3.3. MFC 8626 with valve type 2875 (16 W coil)	6
3.4. MFC 8626 with valve type 2875 (16 W coil) and base block for large nominal flow rates	6
3.5. MFC 8626 with valve type 6024 (18 W coil)	7
3.6. MFC 8626 with valve type 6024 (18 W coil) and base block for large nominal flow rates	7
3.7. MFC 8626 with valve type 2836 (24 W coil)	8
3.8. MFC 8626 with valve type 2836 (24 W coil) and base block for large nominal flow rates	8
4. Device / process connections	9
4.1. Pin assignment	9
5. Performance specifications	11
5.1. Flow characteristic.....	11
Nominal flow range of typical gases.....	11
6. Product operation	11
6.1. Measuring principle	11
7. Ordering information	12
7.1. Bürkert eShop – Easy ordering and quick delivery.....	12
7.2. Recommendation regarding product selection	12
7.3. Bürkert product filter.....	12
7.4. Ordering chart accessories.....	12
7.5. Adapter sketch.....	13

1. General technical data

Product properties	
Dimensions	Detailed information can be found in chapter "3. Dimensions" on page 5.
Materials	
Housing	Aluminium (black anodized) or stainless steel
Body	Aluminium (coated)
Seal	FKM or EPDM
Weight	2.5 kg (Al, 16 W valve) 4.5 kg (VA, 16 W valve)
LED display	Indication for: 1. Power 2. Communication 3. Limit 4. Error
Performance data	
Operating pressure (max.)	10 bar (depending on the nominal valve size)
Response time (t95 %)	< 500 ms
Nominal flow range ¹⁾ (Q _{Nom})	20...1500 l _v /min ²⁾ , Reference medium N ₂ (higher flow rates on request) Detailed information can be found in chapter "5.1. Flow characteristic" on page 11.
Measuring accuracy	± 1.5 % o. R. ³⁾ ± 0.3 % F. S. ⁴⁾
Repeatability	± 0.1 % F. S.
Measuring range	1:50 (With vertical installation position with flow from top to bottom the measuring range is 1:10)
Actuator (normally closing)	
Nominal valve sizes	0.8...12 mm
k _{vs} -values	0.02...2.8 m ³ /h
Electrical data	
Electrical connection	
Standard	Socket M16, round, 8 pin and socket D-Sub HD15, 15 pin
Additionally for PROFIBUS DP	M12 socket, 5 pin or D-Sub 9 pin
Additionally for CANopen	Plug M12, 5 pin or D-Sub 9 pin
RS485 version only	Plug D-Sub 9 pin
Operating voltage	24 V DC
Power consumption (max.)	12.5 W...37 W (depending on version)
Residual ripple (at DC)	< 2 %
Voltage tolerance	± 10 %
Medium data	
Operating medium	Neutral, non-contaminated gases, others on request
Calibration medium	Operating gas or air with conversion factor
Temperature of gas	-10...+70 °C (-10...+60 °C for oxygen)
Process/Port connection & communication	
Port connection	G ¼, G ⅜, G ½, G ¾, G 1 NPT ¼, NPT ⅜, NPT ½, NPT ¾, NPT 1 With screw-in fitting For more detailed information, please refer to the product enquiry form at the end of the document.
Analogue communication	
Output signal (Actual value)	Analogue signal version: 0...5 V, 0...10 V, 0...20 mA or 4...20 mA Field bus version: None RS485 version (only D-Sub, 9 pin): None
Max. Current Voltage output	Analogue signal version: 10 mA Field bus version: None RS485 version (only D-Sub, 9 pin): None
Max. Load current output	Analogue signal version: 600 Ω Field bus version: None RS485 version (only D-Sub, 9 pin): None
Fieldbus option	
(D-Sub HD15 covered by sealing cap), pins for analogue inputs/outputs not assigned)	Analogue signal version: None Fieldbus version: PROFIBUS-DP, CANopen RS485 version (only D-Sub, 9 pin): Modbus RTU (via RS interface)

Digital communication

Possible via adapter:	Analogue signal version: RS232 (supports Modbus RTU) RS485, RS422 or USB
Possible via adapter:	Fieldbus version: None RS485 version (only D-Sub, 9 pin): RS485, RS422 USB

Binary inputs

(Default, other functions selectable)	Analogue signal version: Three: 1. Start Autotune / 2. not assigned / 3. not assigned Fieldbus version:: Three: 1. Start Autotune / 2. not assigned / 3. not assigned RS485 version (only D-Sub, 9 pin): One: not assigned
---------------------------------------	--

Binary outputs

(Default, other functions selectable)	Analogue signal version: Two relay outputs: 1. Limit (Q_{Nom} almost reached) 2. Error (e.g. sensor fault) Load capacity: max. 60 V, 1 A, 60 VA Fieldbus version: Two relay outputs: 1. Limit (Q_{Nom} almost reached) 2. Error (e.g. sensor fault) Load capacity: max. 60 V, 1 A, 60 VA RS485 version (only D-Sub, 9 pin): One relay output: 1. Limit (Q_{Nom} almost reached) Load capacity: max. 25 V, 1 A, 25 VA
---------------------------------------	--

Environment and installation

Installation position	Horizontal or vertical
Ambient temperature	-10...+45 °C (higher temperatures on request)
Degree of protection (with connected cables)	IP50 (Version RS485, RS422) IP65

2. Materials**2.1. Chemical Resistance Chart – Bürkert resistApp****Bürkert resistApp – Chemical Resistance Chart**

You want to ensure the reliability and durability of the materials in your individual application case? Verify your combination of media and materials on our website or in our resistApp.

[Start Chemical Resistance Check](#)

3. Dimensions

3.1. MFC 8626 with valve type 2873 (9 W coil)

Note:

Dimensions in mm

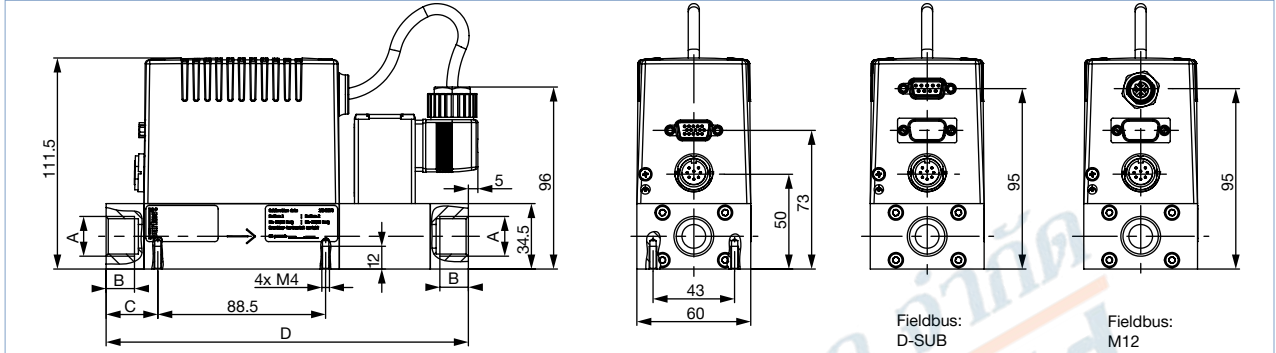

A	B	C	D
G ¼; NPT ¼	10	22.25	181
G ⅜; NPT ⅜	11	22.25	181
G ½; NPT ½	14	27.25	191
G ¾; NPT ¾	15	27.25	191

3.2. MFC 8626 with valve type 2873 (9 W coil) and base block for large nominal flow rates

Note:

Dimensions in mm

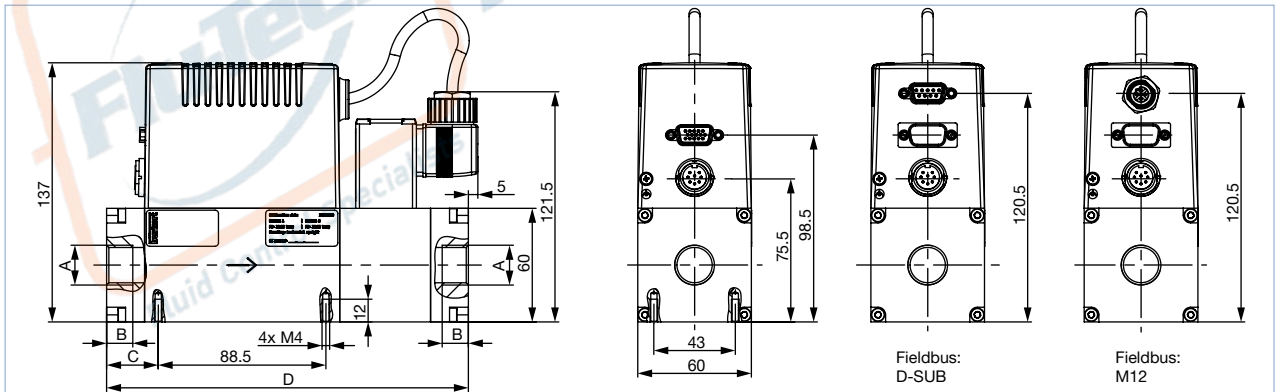

A	B	C	D
G ⅜; NPT ⅜	12	27.25	191
G ½; NPT ½	14	27.25	191
G ¾; NPT ¾	15	27.25	191
G 1	17	27.5	191

DTS 100001124 EN Version: U Status: RL (released | freigegeben | valide) printed: 27.09.2021

3.3. MFC 8626 with valve type 2875 (16 W coil)

Note:

Dimensions in mm

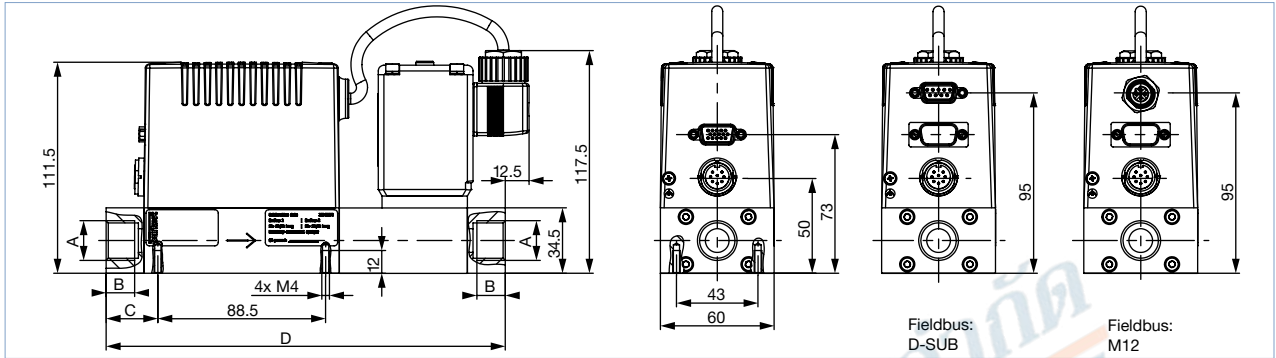

A	B	C	D
G ¼; NPT ¼	10	22.25	200.5
G ⅜; NPT ⅜	11	22.25	200.5
G ½; NPT ½	14	27.25	210.5
G ¾; NPT ¾	15	27.25	210.5

3.4. MFC 8626 with valve type 2875 (16 W coil) and base block for large nominal flow rates

Note:

Dimensions in mm

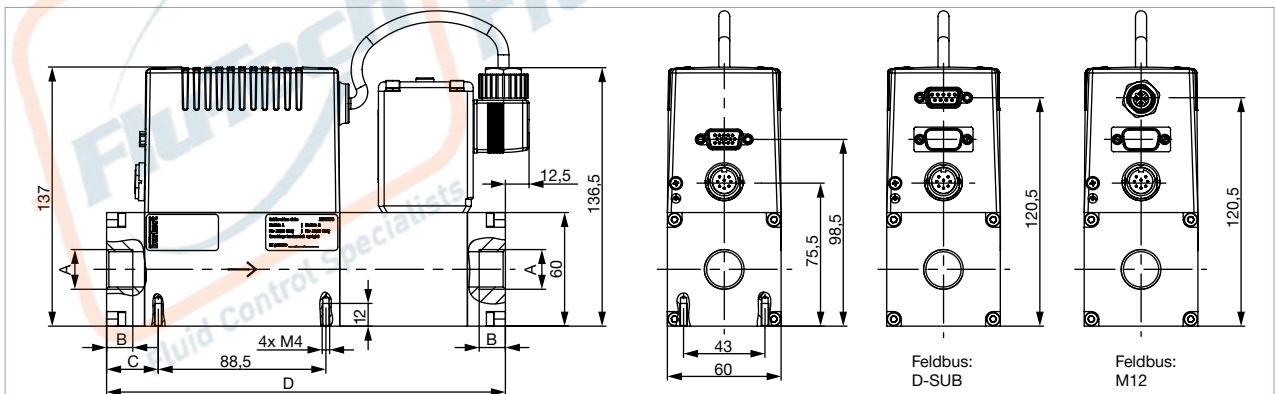

A	B	C	D
G ⅜; NPT ⅜	12	27.25	210.5
G ½; NPT ½	14	27.25	210.5
G ¾; NPT ¾	15	27.25	210.5
G 1	17	27.5	210.5

DTS 100001124 EN Version: U Status: RL (released | freigegeben | valide) printed: 27.09.2021

3.5. MFC 8626 with valve type 6024 (18 W coil)

Note:

Dimensions in mm

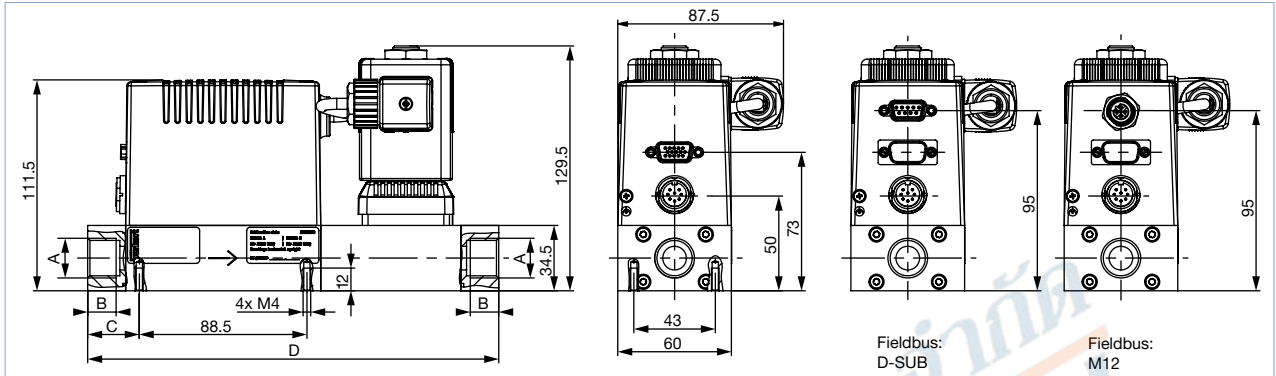

A	B	C	D
G ¼; NPT ¼	10	22.25	207
G ⅜; NPT ⅜	11	22.25	207
G ½; NPT ½	14	27.25	217
G ¾; NPT ¾	15	27.25	217

3.6. MFC 8626 with valve type 6024 (18 W coil) and base block for large nominal flow rates

Note:

Dimensions in mm

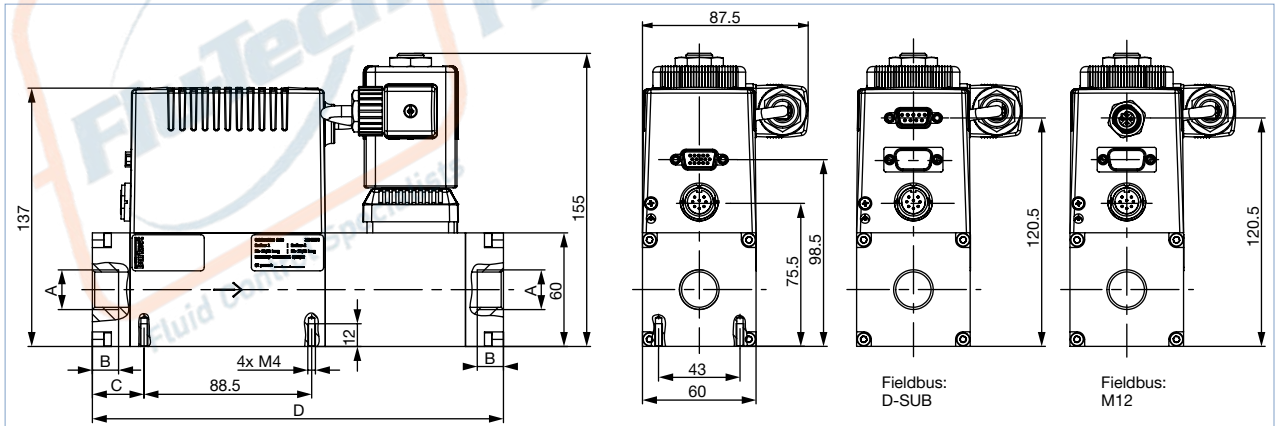

A	B	C	D
G ⅜; NPT ⅜	12	27.25	217
G ½; NPT ½	14	27.25	217
G ¾; NPT ¾	15	27.25	217
G 1	17	27.5	217

DTS 100001124 EN Version: U Status: RL (released | freigegeben | valide) printed: 27.09.2021

3.7. MFC 8626 with valve type 2836 (24 W coil)

Note:

Dimensions in mm

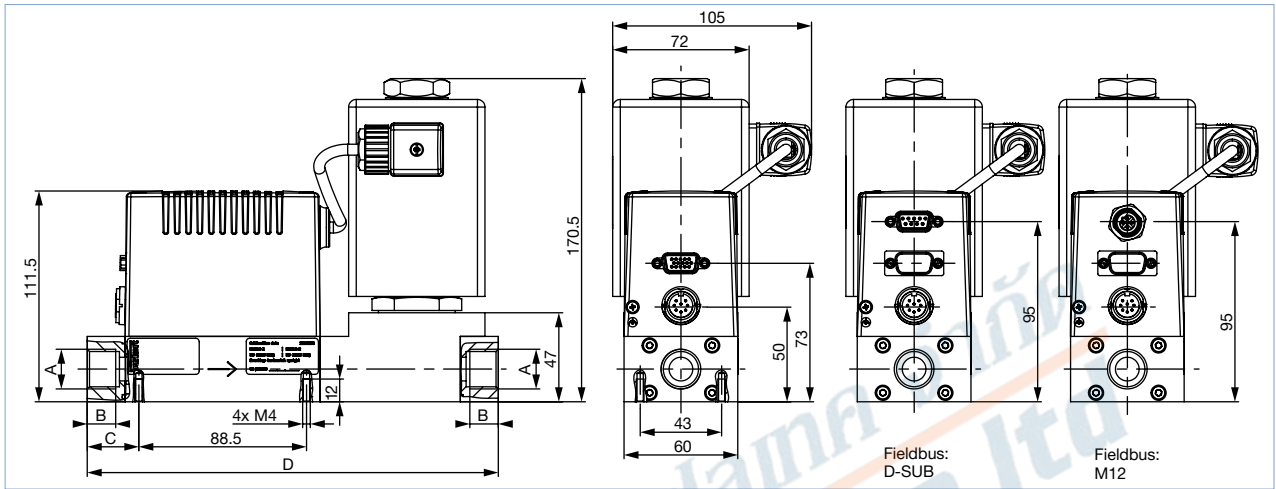

A	B	C	D
G ¼; NPT ¼	10	22.25	207
G ⅝; NPT ⅝	11	22.25	207
G ½; NPT ½	14	27.25	217
G ¾; NPT ¾	15	27.25	217

3.8. MFC 8626 with valve type 2836 (24 W coil) and base block for large nominal flow rates

Note:

Dimensions in mm

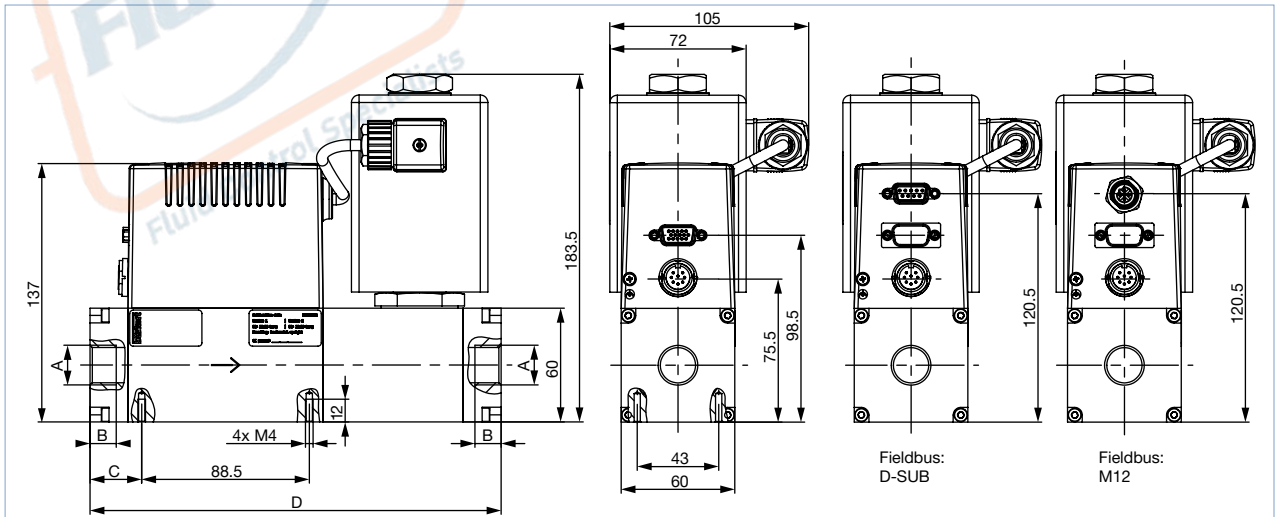

A	B	C	D
G ⅝; NPT ⅝	12	27.25	217
G ½; NPT ½	14	27.25	217
G ¾; NPT ¾	15	27.25	217
G 1	17	27.5	217

DTS 100001124 EN Version: U Status: RL (released | freigegeben | valide) printed: 27.09.2021

4. Device / process connections

4.1. Pin assignment

Note:

- Optional Pin 1 and 2 with bus version as transmitter input possible.
- The cable length for RS232/actual value signal is limited to 30 meters.

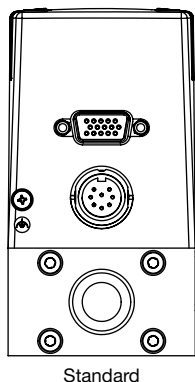

Terminal block 4 pin	Pin	Assignment	
		Analogue control unit	Bus control
	1	Set value input +	Not connected
	2	Set value input GND	Not connected
	3	Actual value output +	Not connected
	4	Binary input 2	
	5	12 V output (only for factory use)	
	6	RS232 TxD (direct connection to computer)	
	7	Binary input 1	
	8	GND (for binary inputs)	
	9	Only internal use (do not connect!)	
	10	12 V output (only for internal company use)	
	11	12 V output (only for internal company use)	
	12	Binary input 3	
	13	Actual value output GND	Not connected
	14	RS232 RxD (direct connection to computer)	
	15	DGND (for RS232-interface)	

Socket M16 round 8 pin	Pin	Assignment
	1	24 V-Supply +
	2	Relay 1 – reference contact
	3	Relay 2 – reference contact
	4	Relay 1 – normally closed
	5	Relay 1 – normally open
	6	24 V-Supply GND
	7	Relay 2 – normally open
	8	Relay 2 – normally closed

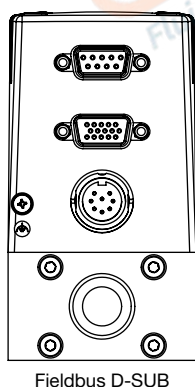

Socket D-Sub 9 pin (only for fieldbus version)	Pin	Assignment	
		PROFIBUS DP	CANopen
	1	Shield	Shield
	2	Not connected	CAN-L data line
	3	RxD/TxD - P (B-line)	GND
	4	RTS (control signal for repeater)	Not connected
	5	GND	Not connected
	6	VDD (only for termination resistor)	Not connected
	7	Not connected	CAN-H data line
	8	RxD/TxD - N (A-line)	Not connected
	9	Not connected	Not connected

DTS 100001124 EN Version: U Status: RL (released | freigegeben | valide) printed: 27.09.2021

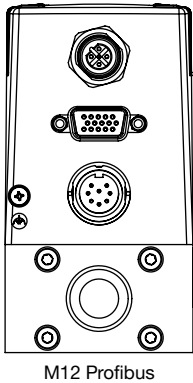

PROFIBUS DP – Socket B-coded M12 (DPV1 max. 12 Mbaud)

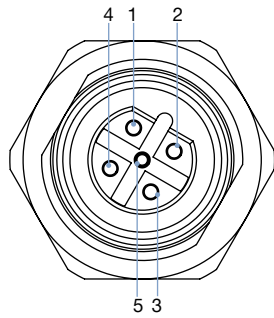

Pin	Assignment
1	VDD (only for termination resistor)
2	RxD/TxD – N (A-line)
3	DGND
4	RxD/TxD – P (B-line)
5	Not connected

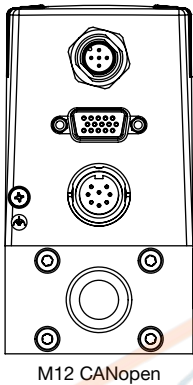

CANopen – Plug A-coded M12

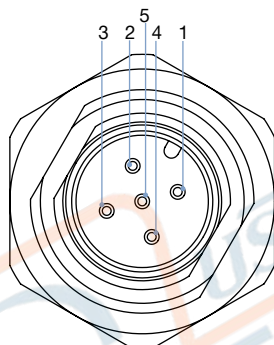

Pin	Assignment
1	Shield
2	Not connected ¹⁾
3	DGND
4	CAN_H
5	CAN_L

1.) Optional configuration with 24 V DC possible for power supply via fieldbus connector. With this no power supply connection on round M16 plug needed.

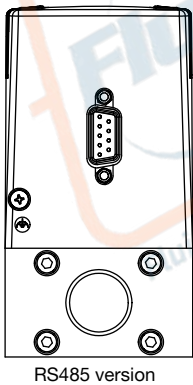

Plug D-Sub 9 pin

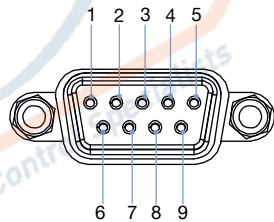

Pin	Assignment
1	Binary input (related to GND Pin2)
2	GND
3	Power supply +24 V DC
4	Relay, normally opened
5	Relay, normally closed
6	TX+ (RS485-Y) – bridge with pin 9 at half duplex
7	TX- (RS485-Z) – bridge with pin 8 at half duplex
8	RX- (RS485-B)
9	RX+ (RS485-A)

DTS 100001124 EN Version: U Status: RL (released | freigegeben | valide) printed: 27.09.2021

5. Performance specifications

5.1. Flow characteristic

Nominal flow range of typical gases

Note:

All values regarding 1.013 bar(a) and 0 °C (Index N)

Gas	Min. Q_{Nom} [L _N /min]	Max. Q_{Nom} [L _N /min]
Acetylene	20	975
Ammonia	20	1250
Argon	20	1500
Carbon dioxide	20	800
Air	20	2500
Methane	20	750
Propane	20	400
Oxygen	20	2500
Nitrogen	20	2500

6. Product operation

6.1. Measuring principle

This sensor works as a hot-film anemometer in the so-called CTA operational mode (Constant Temperature Anemometer). To do this, two resistors with precisely specified temperature coefficients located directly in the media flow and three resistors located outside the flow are connected together to form a bridge.

The first resistor in the gas flow (R_T) measures the fluid temperature, while the second, low-value resistor (R_S) is heated so that it is maintained at a fixed, predefined over-temperature with respect to the fluid temperature.

The heating current required to maintain this is a measure of the heat being removed by the flowing gas, and represents the primary measurement.

An adequate flow conditioning within the MFM and the calibration with high-quality flow standards ensure that the mass of gas flowing per time unit can be derived from the primary signal with high accuracy.

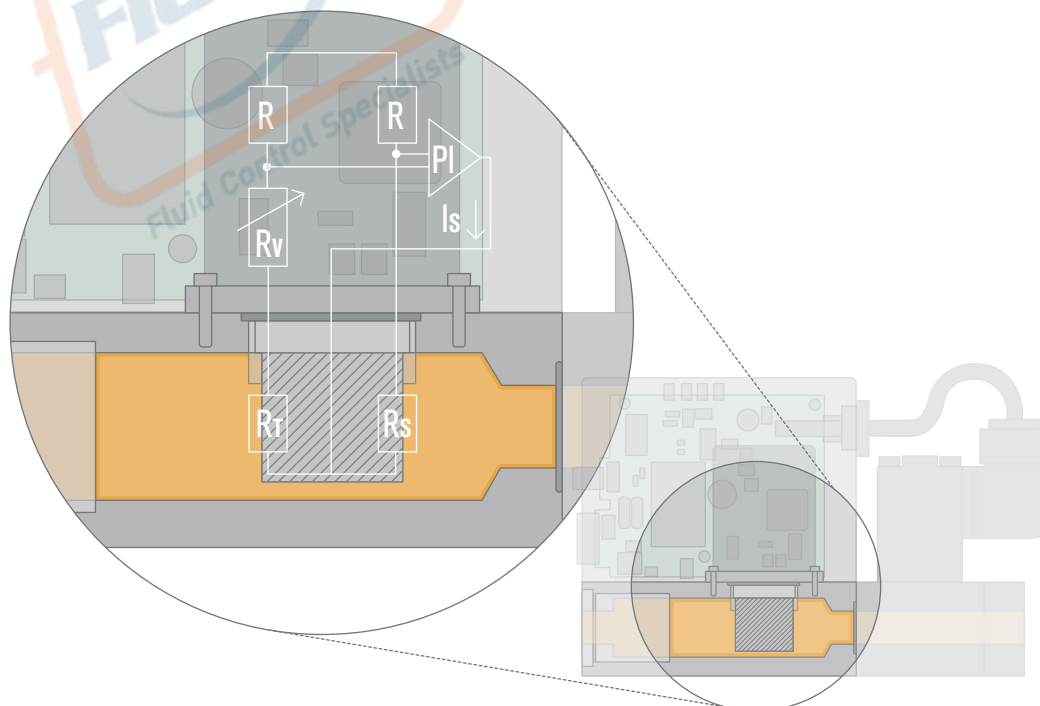

7. Ordering information

7.1. Bürkert eShop – Easy ordering and quick delivery



Bürkert eShop – Easy ordering and fast delivery

You want to find your desired Bürkert product or spare part quickly and order directly? Our online shop is available for you 24/7. Sign up and enjoy all the benefits.

[Order online now](#)

7.2. Recommendation regarding product selection

Note:

Please use the **Product Enquiry Form** at the end of this document for unit design details and send us a copy of the enquiry with information about the application.

For the proper choice of the actuator orifice within the MFC, not only the required maximum flow rate Q_{Nom} , but also the pressure values directly before and after the MFC (p_1 , p_2) at this flow rate Q_{Nom} should be known. In general, these pressures are not the same as the overall inlet and outlet pressures of the whole plant, because usually there are additional flow resistors (tubing, additional shut-off valves, nozzles etc.) present both before and after the controller.

Please use the **Product Enquiry Form** at the end of this document to indicate the pressures directly before and after the MFC. If these should be unknown or not accessible to a measurement, estimates are to be made by taking into account the approximate pressure drops over the flow resistors before and after the MFC, respectively, at a flow rate of Q_{Nom} . In addition, please quote the maximum inlet pressure $p_{1, max}$ to be encountered. This data is needed to make sure the actuator is able to provide a close-tight function within all the specified modes of operation.

7.3. Bürkert product filter



Bürkert product filter – Get quickly to the right product

You want to select products comfortably based on your technical requirements? Use the Bürkert product filter and find suitable articles for your application quickly and easily.

[Try out our product filter](#)

7.4. Ordering chart accessories

Description	Article no.
Connections/Cables	
Round plug M16, 8 pin (solder connection)	918299
Round plug M16, 8 pin with 5 m cable	787733
Round plug M16, 8 pin with 10 m cable	787734
Plug D-Sub HD15, 15 pin with 5 m cable	787735
Plug D-Sub HD15, 15 pin with 10 m cable	787736
Adapters¹⁾	
RS232 adapter for connection to a computer, connection with an extension cable (Article no. 917039)	654757
Extension cable for RS232 9 pin socket/plug 2 m	917039
RS422 adapter (RS485 compatible)	666370
USB adapter	670696
USB connection cable 2 m	772299

Description	Article no.
Adapter for manual setting of bus address	667525
Communication software Mass Flow Communicator	LINK ▶
Accessories for Fieldbus	
PROFIBUS-DP (B-coded)	
Plug M12 ^{2.)}	918198
Socket M12 (coupling) ^{2.)}	918447
Y-junction ^{2.)}	902098
T-junction	918531
Termination resistor	902553
GSD-File (PROFIBUS), EDS-File (CANopen)	LINK ▶
CANopen (A-coded)	
Plug M12 ^{2.)}	917115
Socket M12 (coupling) ^{2.)}	917116
Y-Stück ^{2.)}	788643
T-junction	On request
Termination resistor	On request
GSD-File (PROFIBUS), EDS-File (CANopen)	LINK ▶

1.) The adapters serve mainly for initial operation or diagnosis. Those are not obligatory for continuous operation.

2.) The M12 single connectors as listed here are not suitable for their simultaneous use with the Y-piece for reasons of space. Please always use at least one commercially available overmoulded cable whose connector is usually smaller.

7.5. Adapter sketch

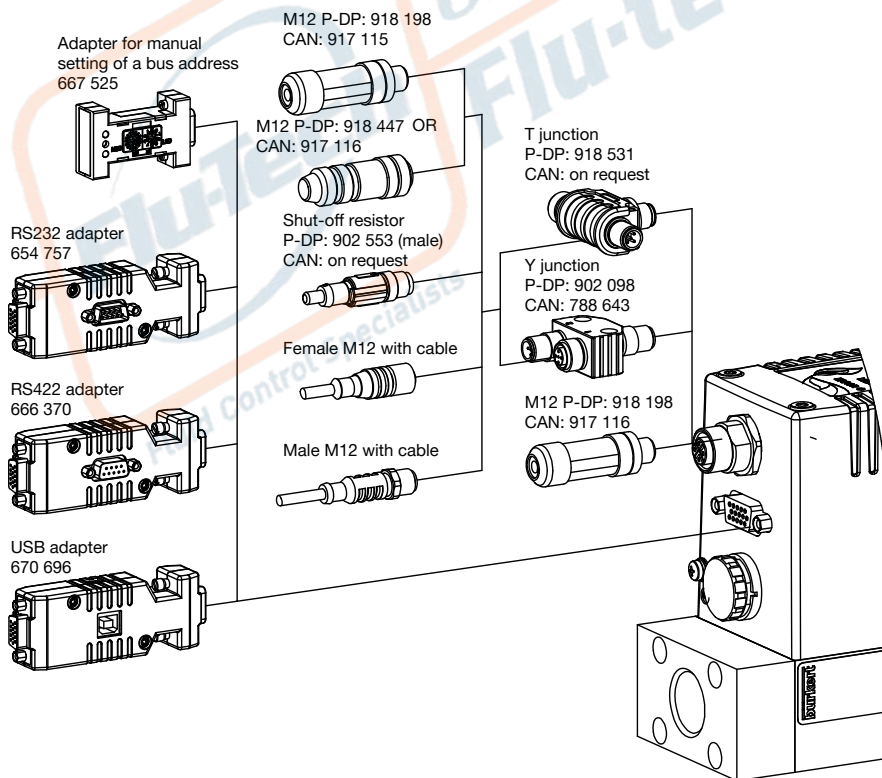

DTS 100001124 EN Version: U Status: RL (released | freigegeben | valide) printed: 27.09.2021