



2/2 or 3/2 way Rocker-Solenoid Valve with separating diaphragm

- For maximum chemical resistance requirements
- Compact design with 16 mm width and Cv ratings up to 0.058
- Flexible design for custom manifold assemblies
- High back pressure tightness, excellent cleanability and 100 % duty cycle
- Normally closed, normally open and universal function



Product variants described in the data sheet may differ from the product presentation and description.

Can be combined with

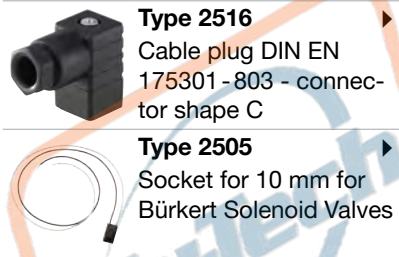

Type 2516
Cable plug DIN EN 175301-803 - connector shape C

Type 2505
Socket for 10 mm for Bürkert Solenoid Valves

Type description

The direct-acting rocker solenoid valves with isolating diaphragm of Type 6606 (2/2- and 3/2 way) are high quality valves for analytical technology. They have minimal dead volume and internal volume with few crevices making them easy to flush out. The fluid only comes into contact with the body material and the FFKM seal. The heat transfer to the medium is minimal. The fluid path is isolated from the coil by a stainless steel plate. The valves are ideal for dosing, filling, mixing and distributing of small quantities of fluid for medical, analytical and laboratory applications.

Table of contents

1. General technical data	3
2. Circuit functions	3
3. Materials	4
3.1. Chemical Resistance Chart – Bürkert resistApp.....	4
3.2. Material specifications.....	4
4. Dimensions	5
4.1. Threaded port version (G 1/8, NPT 1/8) with rectangular plug (Type 2505).....	5
4.2. Threaded port version (UNF 1/4...28) plug-in connection top (Type 2516).....	5
4.3. Tube connection with plug-in connection lateral (Type 2516).....	6
4.4. Sub-base version with flying leads.....	7
4.5. Bürkert sub-base interface 3-way (standard).....	8
4.6. Bürkert sub-base interface 2-way (standard).....	8
4.7. Bürkert sub-base interface 2-way (low dead volume).....	9
4.8. Manifolds in PEEK for Bürkert sub-base interface 2-way.....	10
5. Performance specifications	11
5.1. Internal volume.....	11
5.2. Medium temperature.....	11
6. Ordering information	11
6.1. Bürkert eShop – Easy ordering and quick delivery.....	11
6.2. Bürkert product filter.....	11
6.3. Ordering chart.....	12
6.4. Ordering chart accessories.....	13
Manifolds in PEEK for Bürkert sub-base interface 2-way.....	13
Cable plug Type 1054 and rectangular plug Type 2505.....	13
Cable plug Type 2516, plug-in connection C acc. to DIN EN 175301-803.....	13

1. General technical data

Product properties	
Dimensions	Detailed information can be found in chapter "4. Dimensions" on page 5.
Materials	
Fluid housing	PEEK, PVDF
Seal	FFKM
Internal volume ¹⁾	Sub-base: starting at 44 µl G 1/8 and NPT 1/8: starting at 100 µl UNF 1/4...28: starting at 25 µl Tube connection: starting at 33 µl < 10 µl available on request
Orifice	DN 0.8...DN 1.6
Electrical data	
Operating voltage	12/24 V DC, other voltages are available on request
Voltage tolerance	± 10 %
Power consumption	3.4 W
Duty cycle	100 % continuous rating Manifold mounting: If media or ambient temperatures are above + 40 °C: intermittent operation 40 % (minimum 10 min)
Performance data	
Response times ²⁾	Open: ca. 25 ms (Pressure rise 0...10 %) Closing: ca. 25 ms (Pressure drop 100...90 %)
Medium data	
Media	Resistant to neutral and aggressive liquids and gases
Media temperature ³⁾	- 10...55 °C
Approvals and certificates	
Protection class	IP65 with flying leads and cable plug Type 1054 IP30 with Rectangular plug Type 2505
Product connections	
Port connection	Bürkert sub-base (16 × 27 mm) G 1/8 NPT 1/8 UNF 1/4...28 Tube connection
Electrical connection ⁴⁾	Plug-in connection C acc. to DIN EN 175301-803 for cable plug Type 2516 top/lateral 2 FEP-leads, AWG 24, length 500 mm Rectangular cable plug, Type 2505
Environment and installation	
Installation	As required, preferably with actuator upright
Ambient temperature (max.)	55 °C

1.) The internal volume can vary depending on the housing. For further information see "5.1. Internal volume" on page 11.

2.) Measured at valve outlet at 2 bar and +20 °C acc. to DIN ISO 12238:2001

3.) Temperature may vary depending on orifice and seal material. For further information see "5.2. Medium temperature" on page 11.

4.) Other electric connectors and other cable lengths upon request.

2. Circuit functions

Circuit functions	Description
	Type: A, solenoid valve 2/2 way Direct-acting Normally closed
	Type: B, solenoid valve 2/2 way Direct-acting Normally opened

Visit product website ►

3 | 14



บริษัท ฟลูเทค จำกัด
FLU-TECH CO.,LTD

845/3-4 หมู่ 3 ถนนพหลโยธิน ต.เทพารักษ์ อ.เมือง จ.สมุทรปราการ 10270
845/3-4 Thepharak RD., T.Thepharak, A.Muang, Samutprakarn 10270 THAILAND
Tel. 0 2384 6060, Fax 0 2384 5701, Email : sales@flutech.co.th, www.flutech.co.th

Circuit functions	Description
	Type: T, solenoid valve 3/2 way Direct-acting Flow direction optional Universal

3. Materials

3.1. Chemical Resistance Chart – Bürkert resistApp



Bürkert resistApp – Chemical Resistance Chart

You want to ensure the reliability and durability of the materials in your individual application case? Verify your combination of media and materials on our website or in our resistApp.

[Start Chemical Resistance Check](#)

3.2. Material specifications

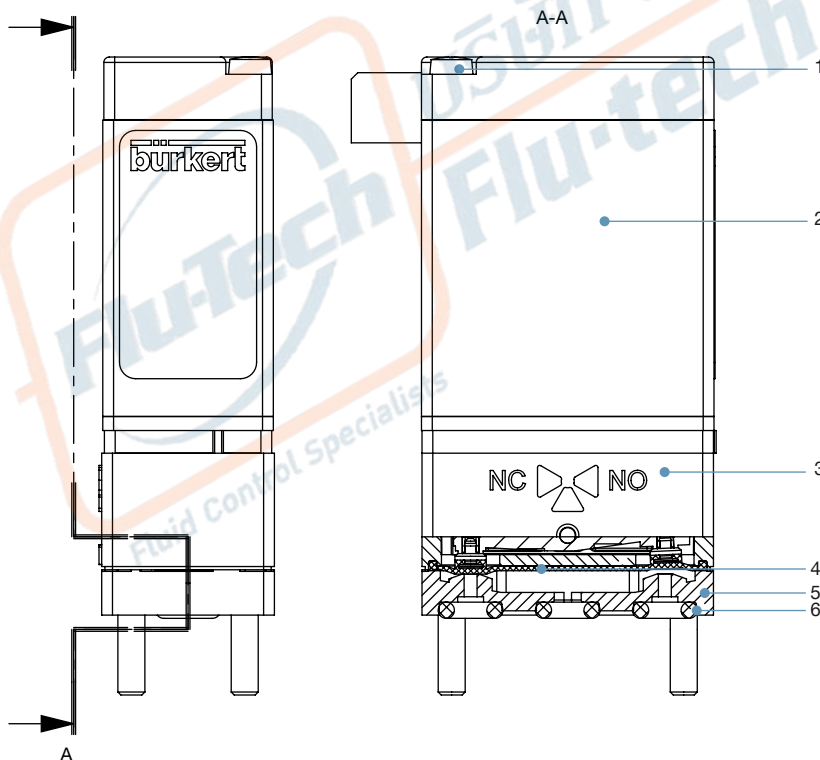

No.	Element	Material
1	Rounded head screw M2.5	A2
2	Coil	Epoxy
3	Actuator housing	PPS
4	Diaphragm (medium contact)	FFKM
5	Fluid housing (medium contact)	PEEK, PVDF
6	Flange seal (medium contact)	FFKM

4. Dimensions

4.1. Threaded port version (G 1/8, NPT 1/8) with rectangular plug (Type 2505)

Note:

- Dimensions in mm
- Other screw length on request
- Self-tapping screws on request

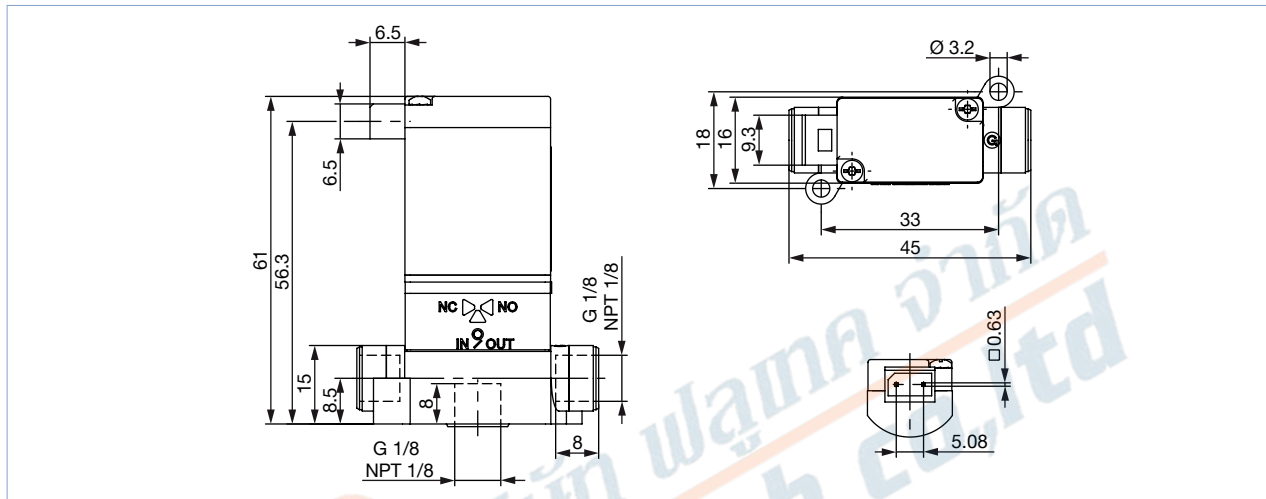

4.2. Threaded port version (UNF 1/4...28) plug-in connection top (Type 2516)

Note:

- Dimensions in mm
- Other screw length on request
- Self-tapping screws on request

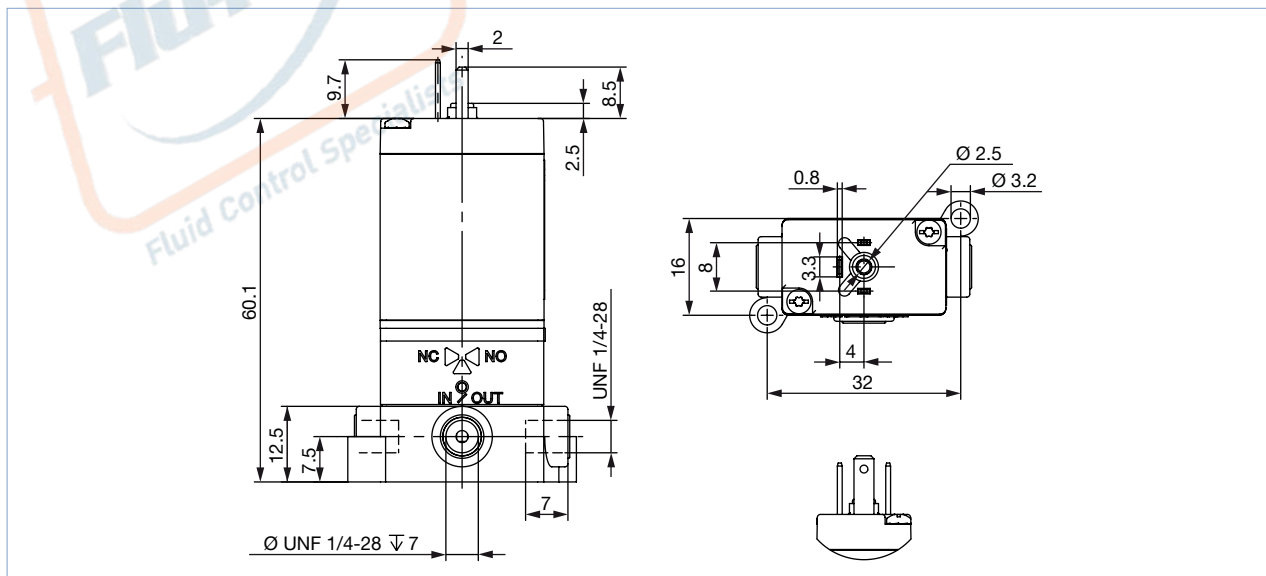

4.3. Tube connection with plug-in connection lateral (Type 2516)

Note:

- Dimensions in mm
- Other screw length on request
- Self-tapping screws on request

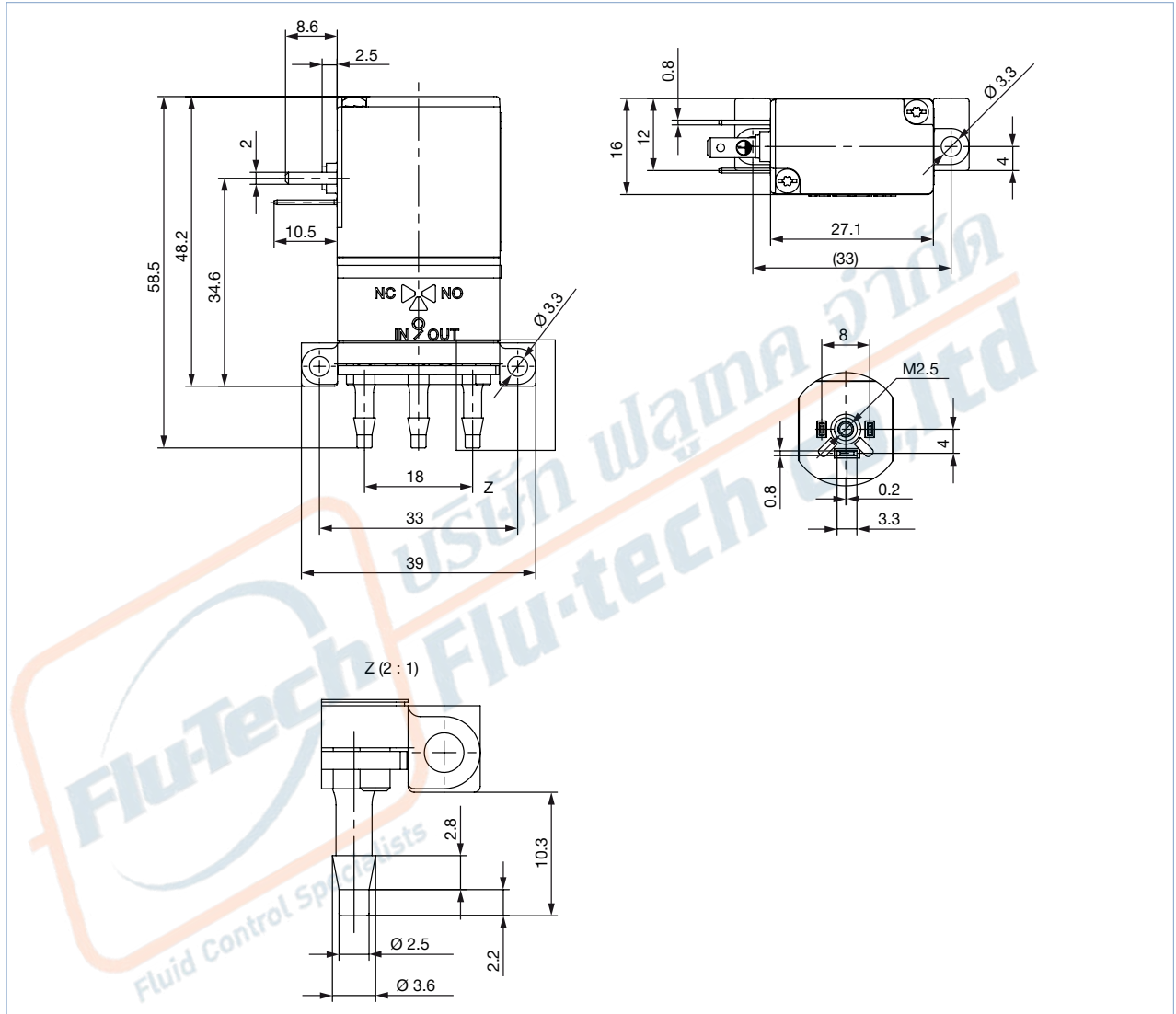

DTS 1000011072 EN Version: M Status: RL (released | freigegeben | valide) printed: 26.05.2020

4.4. Sub-base version with flying leads

Note:

- Dimensions in mm
- Other screw length on request
- Self-tapping screws on request

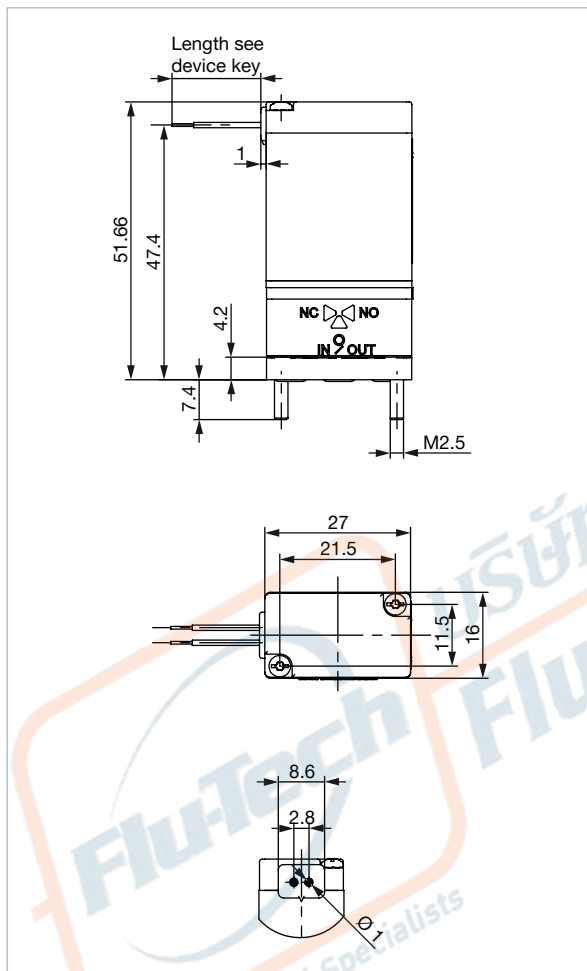

Classification of fluid connections

WWA (circuit function: Type A)
2/2 way, direct-acting, normally closed
energized at NC connection

WWB (circuit function: Type B)
2/2 way, direct-acting, normally opened
energized at NO connection

WWT (circuit function: Type T)
3/2 way, direct-acting, flow direction optional, universal

See chapter "2. Circuit functions" on page 3

4.5. Bürkert sub-base interface 3-way (standard)

Note:

Dimensions in mm

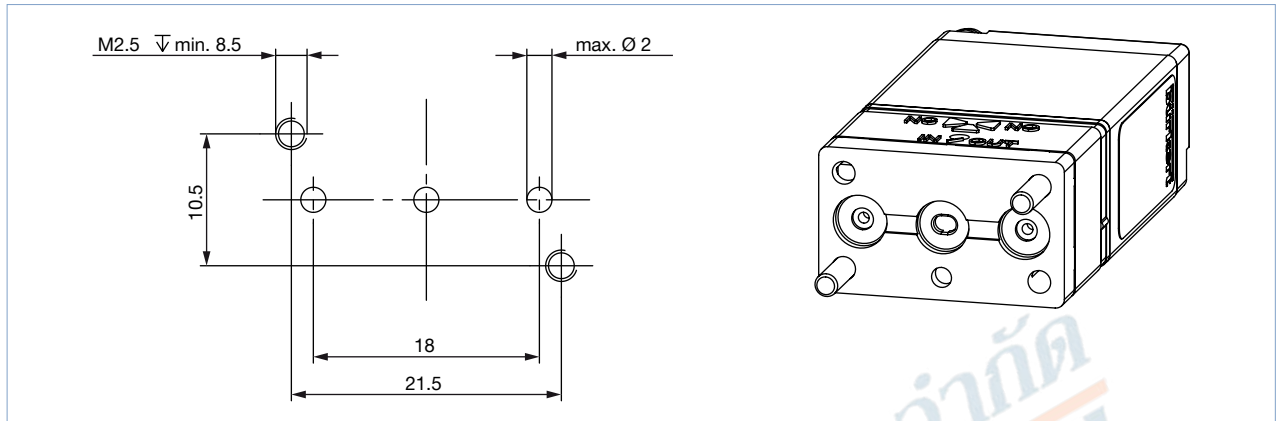

4.6. Bürkert sub-base interface 2-way (standard)

Note:

Dimensions in mm

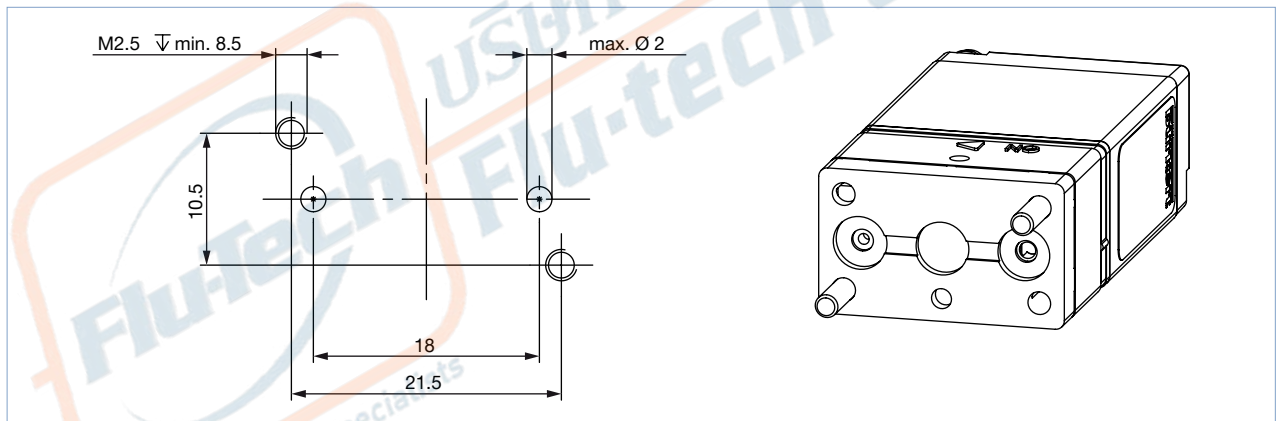

4.7. Bürkert sub-base interface 2-way (low dead volume)

Note:

- Dimensions in mm
- Available on request

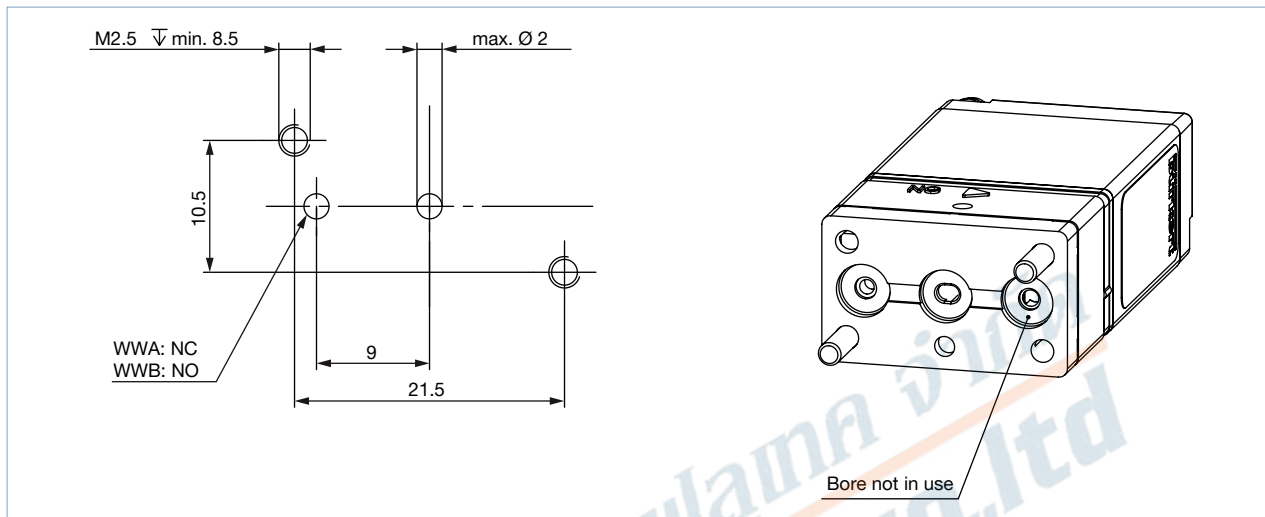

DTS 1000011072 EN Version: M Status: RL (released | freigegeben | valide) printed: 26.05.2020

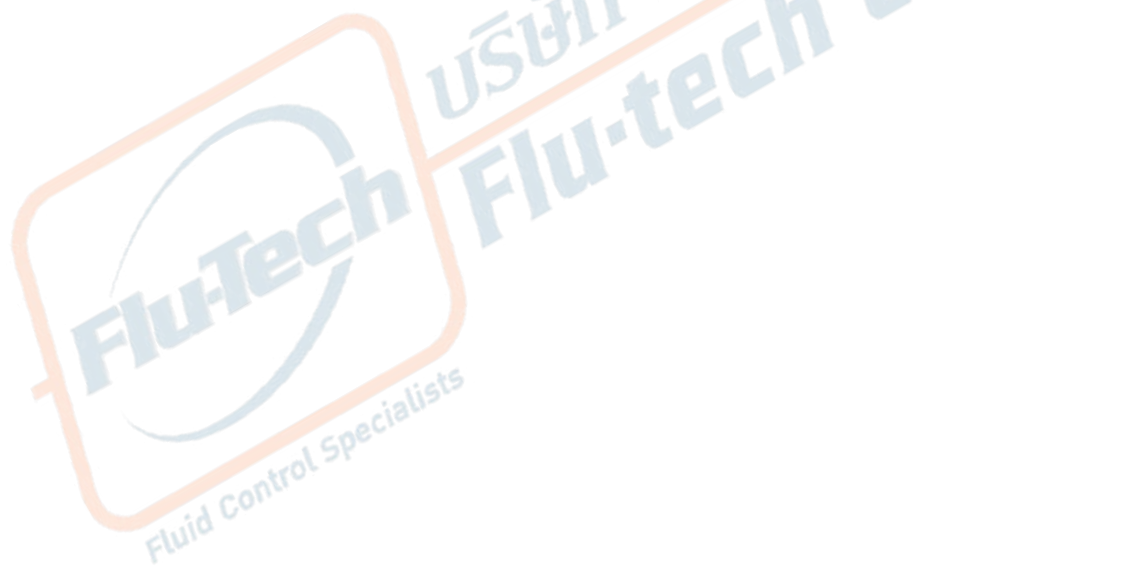

4.8. Manifolds in PEEK for Bürkert sub-base interface 2-way

Note:

- Dimensions in mm
- Port connection UNF 1/4...28
- Consider the screw protrusion!
- Further versions on request

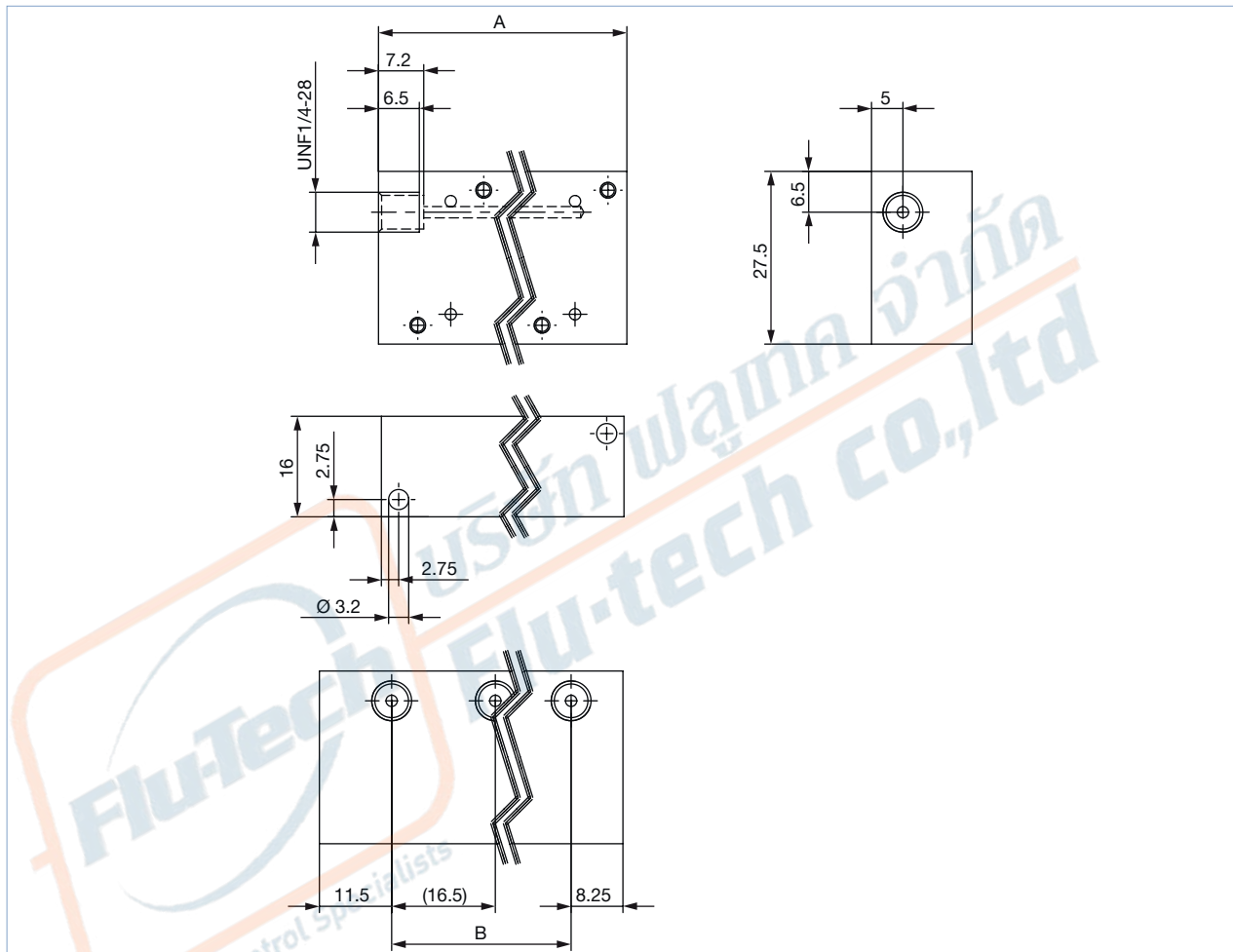

Manifold	A	B	n	Article no.
2-fold	36.25	16.5	2	651506
3-fold	52.75	33	3	651510
4-fold	69.25	49.5	4	651507
5-fold	85.75	66	5	651508
6-fold	102.25	82.5	6	651509
7-fold	118.75	99	7	651521
8-fold	135.25	115.5	8	651522

DTS 1000011072 EN Version: M Status: RL (released | freigegeben | valide) printed: 26.05.2020

5. Performance specifications

5.1. Internal volume

Note:

The internal volume is depending on fluid housing.

Body	2-way low dead volume		2-way		3-way	
	Fluid chamber	Total	Fluid chamber	Total	Fluid chamber	Total
Sub-base	44 µl	54 µl	97 µl	106 µl	90 µl	106 µl
G 1/8, NPT 1/8	–	–	100 µl	211 µl	92 µl	229 µl
UNF 1/4...28	25 µl	69 µl	55 µl	79 µl	54 µl	95 µl
Tube connection	33 µl	112 µl	62 µl	142 µl	69 µl	185 µl

5.2. Medium temperature

Note:

The permissible medium temperature depends on the material and the nominal size.

Description	Orifice	Seal material	Temperature range
Medium temperature	DN 0.8	FFKM	+5...+50 °C
	DN 1.2 and DN 1.6	FFKM	+10...+50 °C
Medium temperature with limitation on switching time and life expectancy	DN 0.8	FFKM	0...+50 °C
	DN 1.2 and DN 1.6	FFKM	+5...+50 °C

6. Ordering information

6.1. Bürkert eShop – Easy ordering and quick delivery



Bürkert eShop – Easy ordering and fast delivery

You want to find your desired Bürkert product or spare part quickly and order directly? Our online shop is available for you 24/7. Sign up and enjoy all the benefits.

[Order online now](#)

6.2. Bürkert product filter



Bürkert product filter – Get quickly to the right product











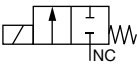





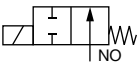

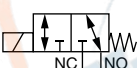

You want to select products comfortably based on your technical requirements? Use the Bürkert product filter and find suitable articles for your application quickly and easily.

[Try out our product filter](#)

6.3. Ordering chart

Note:

- Overpressure with respect to atmospheric pressure
- On request different pressure ranges available

Circuit function	Orifice	Port connection	K _v value	C _v value	Q _{Nn} value	Pressure range	Seal material	Fluid housing material	Electrical connection	Voltage/Frequency	Article no.	
	[mm]		[m ³ /h]	[gal/min]	[l/min]					[V/Hz]		
A, solenoid valve 2/2 way Direct-acting Normally closed 	1.6	G 1/8	0.05	0.058	54	Vac - 2	FFKM	PVDF	Rectangular plug	024/DC	139146 	
									Spade connector sideways	024/DC	137746 	
	1.6	UNF 1/4...28	0.03	0.035	33	Vac - 2	FFKM	PEEK	Rectangular plug	024/DC	258410 	
	1.6	Tube connection	0.045	0.052	49	Vac - 2 ^{1.)}	FFKM	PVDF	Leads, 0.5 m	024/DC	137764 	
									Rectangular plug	024/DC	139147 	
									Leads, 0.5 m	012/DC	137744 	
B, solenoid valve 2/2 way Direct-acting Normally opened 	1.6	UNF 1/4...28	0.03	0.035	33	Vac - 2	FFKM	PEEK	Leads, 0.5 m	012/DC	270871 	
	1.6	G 1/8	0.05	0.058	54	Vac - 2	FFKM	PVDF	Spade connector sideways	024/DC	137747 	
	T, solenoid valve 3/2 way Direct-acting Flow direction optional Universal 	1.6	G 1/8	0.05	0.058	54	Vac - 2	FFKM	PVDF	Leads, 0.5 m	024/DC	137771 
										Rectangular plug	024/DC	139149 
										Spade connector sideways	024/DC	137769 
		1.6	UNF 1/4...28	0.03	0.035	33	Vac - 2	FFKM	PEEK	Rectangular plug	024/DC	258287 
1.6	Tube connection	0.045	0.052	49	Vac - 2	FFKM	PVDF	Leads, 0.5 m	012/DC	137782 		
									024/DC	137783 		
								Rectangular plug	024/DC	139150 		
								Spade connector sideways	012/DC	137781 		
1.6	Sub-base	0.045	0.052	49	Vac - 2	FFKM	PEEK	Leads, 0.5 m	024/DC	137768 		
								Rectangular plug	024/DC	139148 		
								Spade connector sideways	012/DC	137766 		
									024/DC	137765 		

1.) Maximum back pressure 1 bar

6.4. Ordering chart accessories

Manifolds in PEEK for Bürkert sub-base interface 2-way





Note:

Detailed order information can be found in chapter “4.8. Manifolds in PEEK for Bürkert sub-base interface 2-way” on page 10.

Cable plug Type 1054 and rectangular plug Type 2505

Note:



For further versions see datasheet **Type 2505** ▶.

Accessories	Description	Article no.
	Rectangular plug Type 2505 with 300 mm leads, 2 pin	262346 
	Rectangular plug Type 2505 with 3 m cable, 2 pin	252572 

Cable plug Type 2516, plug-in connection C acc. to DIN EN 175301-803

Note:

- The delivery of a cable plug includes a flat gasket and a fixing screw.
- For further versions see datasheet **Type 2516** ▶.

Cable plug	Version	Voltage	Current	Article no. without cable
	Without circuitry	0...250 V AC/DC	Max. 6 A	303141 
	With LED	12...24 V AC/DC	Max. 3 A	303145 
	With LED and varistor	12...24 V AC/DC	Max. 3 A	303148 