



3/2 way pneumatic cartridge solenoid valve

- Compact design with 11 mm width per station
- Orifices from 0,5 mm (9 bar) to 1,2 mm (1,5 bar)
- High durability and reliability
- Low power consumption, as well as optional ATEX Ex ib version
- Design for optimum integration



Product variants described in the data sheet may differ from the product presentation and description.

Type description

Customer specific applications are becoming more complex. Size, fluidic performance, low power consumption and cost efficiency are critical criteria. Therefore the demands on the components used are increasing. Type 6164 was developed with the goal, to simplify pneumatic control with optimum integration of a pilot valve in block and plastic moulding parts. Thus, making a more compact design possible.

This valve sets new standards with its uncompromising reliability, above average life cycle span and excellent fluidic characteristics.

Various certifications and conformities make the use of the valve in medical applications such as media multiplexers in dental technology and oxygen control in respirators possible.

Table of contents

1. General Technical Data	3
2. Circuit functions	4
3. Materials	5
3.1. Chemical Resistance Chart – Bürkert resistApp.....	5
3.2. Material specifications	5
4. Dimensions	6
4.1. Pin and flying leads version	6
4.2. Defining of the installation area	7
Cartridge connection (fully sunken)	7
Cartridge connection (half sunken).....	8
5. Device/Process connections	9
5.1. Pin assignment standard version.....	9
6. Performance specifications	10
6.1. Electrical data for the Exi version	10
7. Product design and assembly	11
7.1. Application examples.....	11
8. Product accessories	12
8.1. Single manifold fully sunken	12
9. Ordering information	12
9.1. Bürkert eShop – Easy ordering and quick delivery.....	12
9.2. Bürkert product filter	12
9.3. Ordering chart.....	13
Standard version.....	13
Explosion proof version	14
9.4. Ordering chart accessories.....	15
Single manifold fully sunken	15
Further accessories	15

1. General Technical Data

Product properties	
Dimensions	Detailed information can be found in chapter "4. Dimensions" on page 6.
Material	
Seal	FKM
Body	PEEK
Further materials in contact with the medium	PA, LCP, MS, Edelstahl... Detailed information can be found in chapter "3.2. Material specifications" on page 5.
Permissible leakage	Vac...10 bar (dependent on the version used) ¹⁾
Weight	6 g (standard version)
Nominal diameter	DN 0.5 / DN 0.8 / DN 1.0 / DN 1.2
Switching function	Detailed information can be found in chapter "2. Circuit functions" on page 4.
Typical product service life	100.000.000 switching cycles (accordance to endurance tests) ²⁾
Performance data	
Pressure range	DN 0.5 (Vac...9 bar) ¹⁾ / DN 0.8 (Vac...7.5 bar) ¹⁾ / DN 1.0 (Vac...5 bar) ¹⁾ / DN 1.2 (Vac...1.5 bar) ¹⁾
Switching times ³⁾	Opening: <5 ms (pressure rise 0...10 %) Closing: <5 ms (pressure drop 100...90 %)
Electrical data	
Operating voltage	12 or 24 V DC (other voltages on request)
Voltage tolerance	± 10 %
Power consumption	0.7 W 2.8 W/0.3 W (with external electric power reduction) 0.3 W (for explosion proof version)
Duty cycle	100 % ED continuous rating
Switching frequency	16 Hz
Switching noise	42 dB ⁴⁾
Medium data	
Medium temperature	
Standard version FKM	-10 °C...+55 °C
Low temperature version FKM	-20 °C...+55 °C (on request)
Operating medium	Neutral gases
Process/Port connection & communication	
Port connection	Bürkert Cartridge Connection
Electrical connection	Plug/Solder, flying leads
Approvals and certificates	
Explosion proof (on request)	
Detailed information can be found in chapter "6.1. Electrical data for the Exi version" on page 10.	
BVS 16 ATEX E 088 X	II 2G Ex ib IIC T6...T4 Gb II 2D Ex ib IIIB T155 °C Db
IECEx BVS 16.0053 X	Ex ib IIC T6...T4 Gb Ex ib IIIB T155 °C Db
Conformity (on request)	UL class 2 Oxygen compatible
Protection class	
Pins	IP00
Special plug	IP40
Flying leads	IP54
Environment and installation	
Installation position	As required
Ambient temperature⁵⁾	
Standard version FKM	-10 °C...+55 °C
Low temperature version FKM	-20 °C...+55 °C

1.) Technical vacuum (-0.8 bar)

2.) Life span is dependent on temperature, pressure, sealing material and operating conditions.

3.) Measurement at the valve outlet according to DIN ISO 12238:2001

4.) According to ISO 3745, testing environment in brass manifold, free-hanging

5.) Depending on installation conditions (see manual), higher temperatures on request

2. Circuit functions

Note:

See "5.1. Pin assignment standard version" on page 9

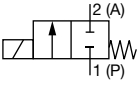
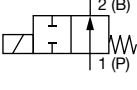
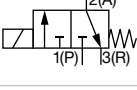
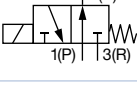
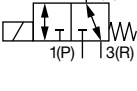
Circuit functions	Description
	Type: A, solenoid valve 2/2 way Direct-acting Normally closed
	Type: B, solenoid valve 2/2 way Direct-acting Normally open
	Type: C, solenoid valve 3/2 way Direct-acting Normally closed
	Type: D, solenoid valve 3/2 way Direct-acting Normally open
	Type: T, solenoid valve 3/2 way Direct-acting Flow direction optional Normally closed

3. Materials

3.1. Chemical Resistance Chart – Bürkert resistApp



Bürkert resistApp – Chemical Resistance Chart

You want to ensure the reliability and durability of the materials in your individual application case? Verify your combination of media and materials on our website or in our resistApp.

[Start Chemical Resistance Check](#)

3.2. Material specifications

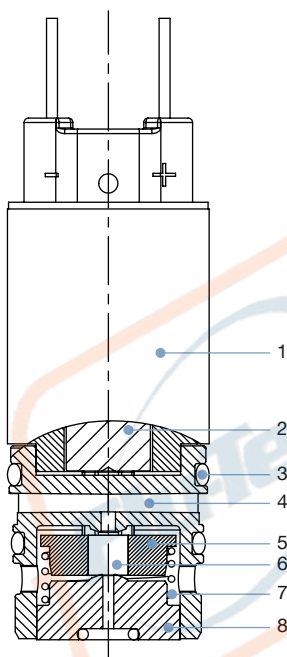

No.	Element	Material
1	Coil housing	1.4113
2	Core (wetted parts)	1.4113
3	O-Rings (wetted parts)	FKM
4	Body (wetted parts)	PEEK
5	Seal switch (wetted parts)	PA
6	Seal (wetted parts)	FKM
7	Spring (wetted parts)	1.4310
8	Fitting (wetted parts)	Brass
-	Coil body (wetted parts, not visible)	LCP

DTS 1000257619 EN Version: M Status: RL (released | freigegeben | validé) printed: 17.09.2020

4. Dimensions

4.1. Pin and flying leads version

Note:

Dimensions in mm

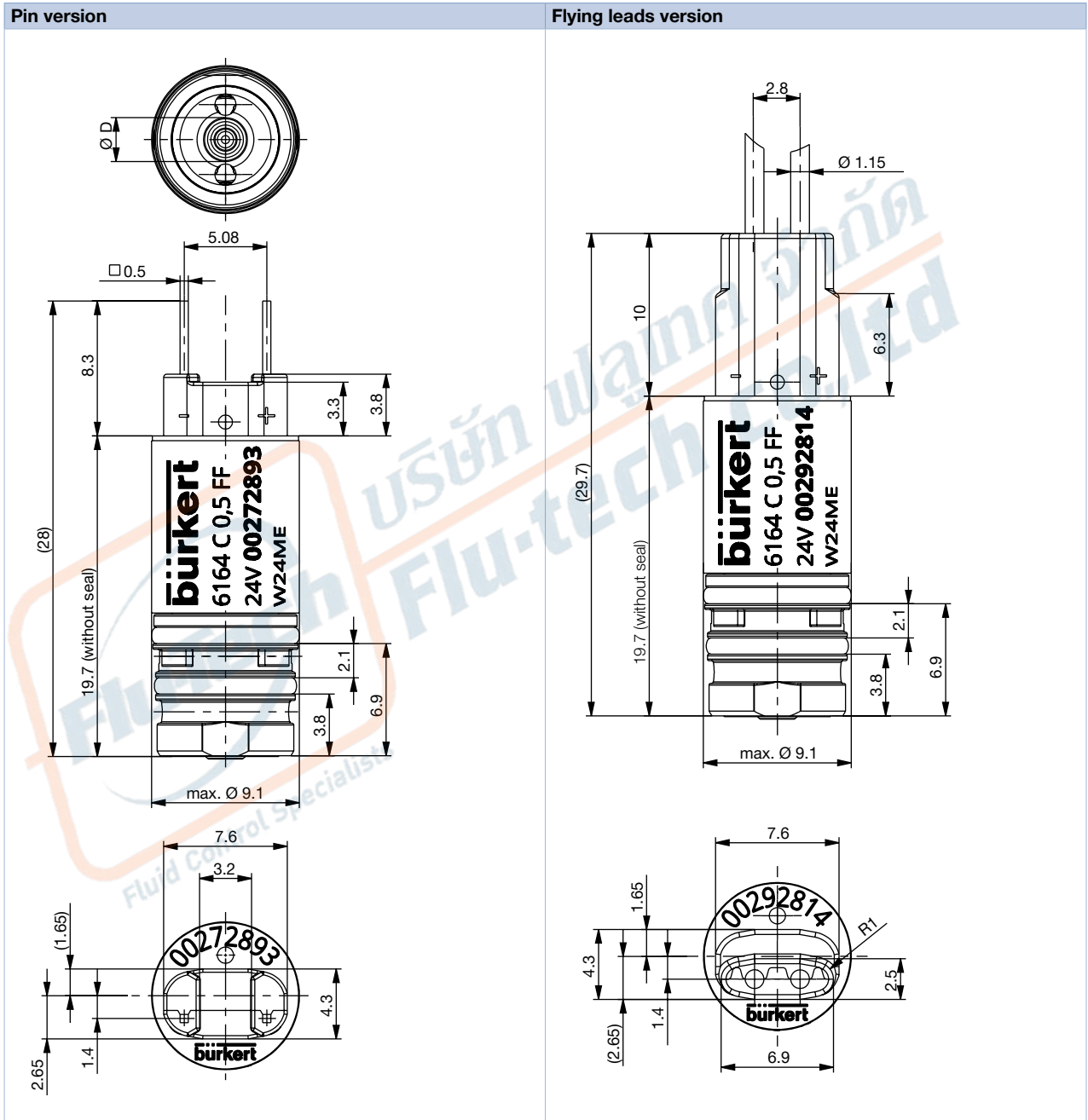

Version	Measurement D
DN < 0.65	Ø 2.7
DN > 0.65	Ø 3.3

DTS 1000257619 EN Version: M Status: RL (released | freigegeben | valide) printed: 17.09.2020

Cartridge connection (half sunken)

Note:

- For explanation see also “7. Product design and assembly” on page 11
- A mounting bracket set is required for mounting, see “9.4. Ordering chart accessories” on page 15.
- Dimensions in mm

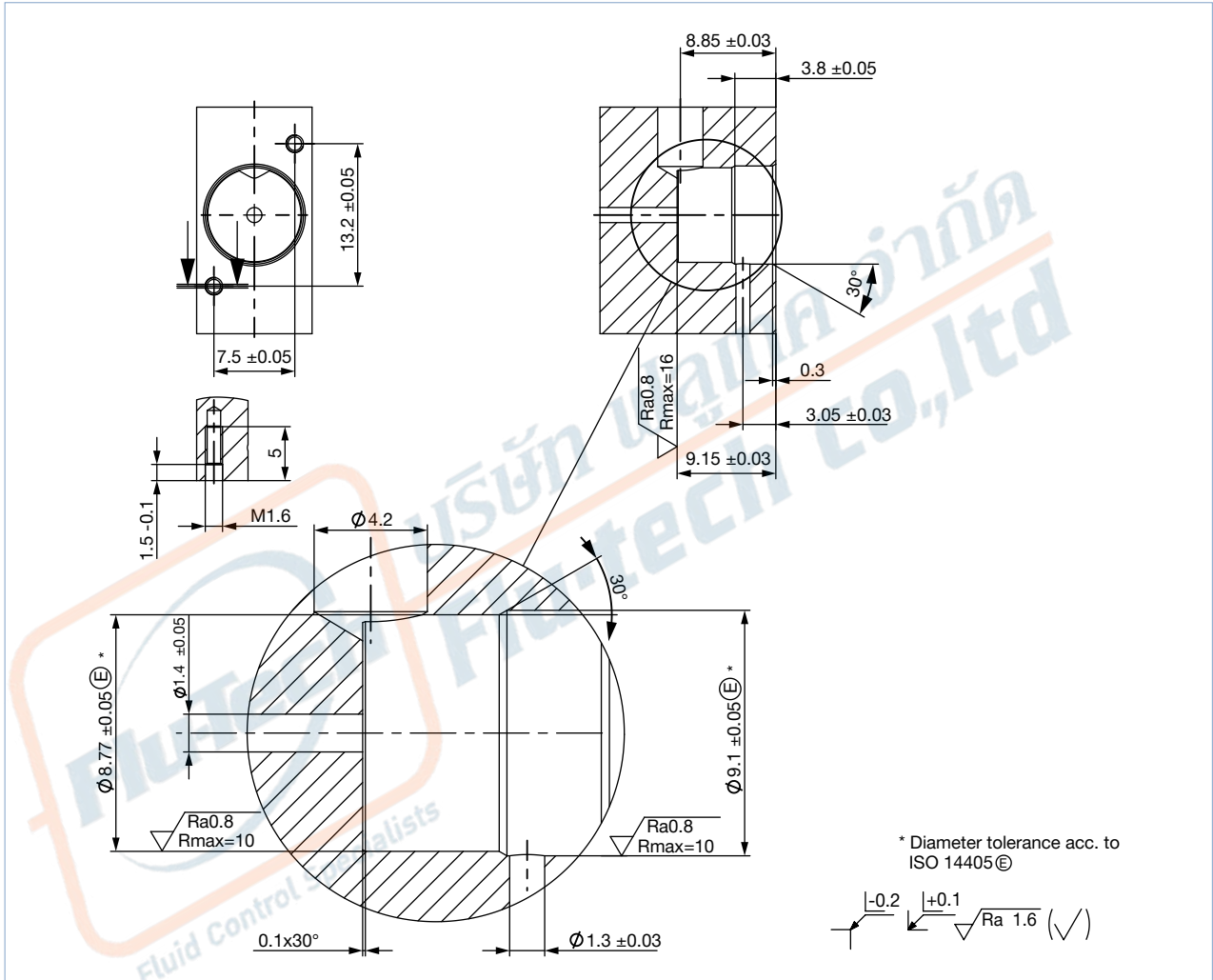







DTS 1000257619 EN Version: M Status: RL (released | freigegeben | valide) printed: 17.09.2020

5. Device/Process connections

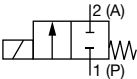
5.1. Pin assignment standard version

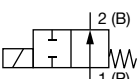
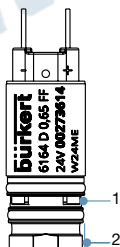
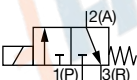
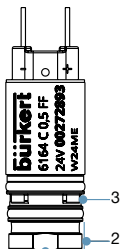
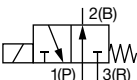
Note:

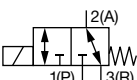
- The pin assignment (marked No. 1, 2 and 3 in the drawing) depends on the circuit function. In the table, compare the respective pin assignment with the corresponding circuit function.
- The polarity must be observed only in the Ex version.

Circuit functions	Port 1	Port 2	Port 3	3 way
A, solenoid valve 2/2 way Direct-acting Normally closed  <p>(same valve as for circuit function C by blind connection to 3)</p>	Pressure port	Working port	Blind	
B, solenoid valve 2/2 way Direct-acting Normally open  <p>(same valve as for circuit function D by blind connection to 3)</p>	Pressure port	Working port	Blind	
C, solenoid valve 3/2 way Direct-acting Normally closed  <p>(applicable to circuit function A by using blind connectors on 3)</p>	Pressure port	Working port	Ventilation	
D, solenoid valve 3/2 way Direct-acting Normally open  <p>(applicable to circuit function B by using blind connectors on 3)</p>	Pressure port	Working port	Ventilation	
T, solenoid valve 3/2 way Direct-acting Flow direction optional Normally closed 	Pressure port	Working port	Ventilation	

DTS 1000257619 EN Version: M Status: RL (released | freigegeben | valide) printed: 17.09.2020

6. Performance specifications

6.1. Electrical data for the Exi version

Note:

- The valve is designed to operate on 24 V DC outputs through an intermediary intrinsically safe apparatus (isolating block or barrier).

Please refer to the **Type 6164** ▶ Instruction Manual for the permissible maximum values/value pairs.

- Type of protection:

BVS 16 ATEX E 088 X: II 2G Ex ib IIC T6...T4 Gb & II 2D Ex ib IIIB T155 °C Db

IECEX BVS 16.0053 X: Ex ib IIC T6...T4 Gb & Ex ib IIIB T155 °C Db

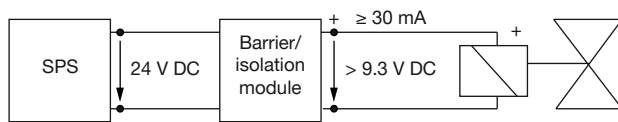

Version	Resistance at 20 °C ± 4 % [Ohm]	Minimum terminal voltage [V]	Minimum current [mA]
Version for use with 300 Ω supply module	320	9.3	29
High-resistance version	510	11.7	23

7. Product design and assembly

7.1. Application examples



DTS 1000257619 EN Version: M Status: RL (released | freigegeben | validé) printed: 17.09.2020

8. Product accessories

8.1. Single manifold fully sunken

Note:

- Dimensions in mm
- Max. tightening torque of the screw must be observed (see operating instructions **Type 6164** ▶)

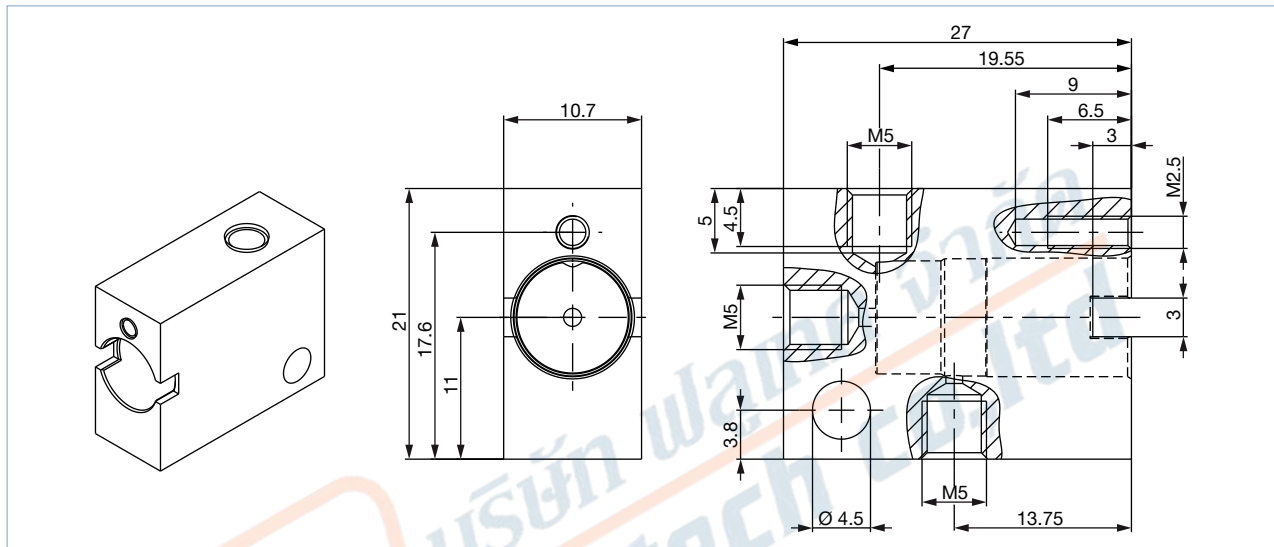

Description	Article no.
Manifold 1 place, brass	695913

9. Ordering information

9.1. Bürkert eShop – Easy ordering and quick delivery



Bürkert eShop – Easy ordering and fast delivery

You want to find your desired Bürkert product or spare part quickly and order directly? Our online shop is available for you 24/7. Sign up and enjoy all the benefits.

[Order online now](#)

9.2. Bürkert product filter



Bürkert product filter – Get quickly to the right product

You want to select products comfortably based on your technical requirements? Use the Bürkert product filter and find suitable articles for your application quickly and easily.

[Try out our product filter](#)

Visit product website ▶

12 | 17



บริษัท ฟลูเทค จำกัด
FLU-TECH CO.,LTD

845/3-4 หมู่ 3 ถ.เทพารักษ์ ต.เทพารักษ์ อ.เมือง จ.สมุทรปราการ 10270
845/3-4 Thepharak RD., T.Thepharak, A.Muang, Samutprakarn 10270 THAILAND
Tel. 0 2384 6060, Fax 0 2384 5701, Email : sales@flutech.co.th, www.flutech.co.th

9.3. Ordering chart

Standard version

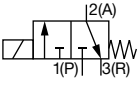
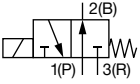
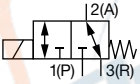
Circuit functions	Port connection	Orifice ventilation 1 → 2	Orifice ventilation 2 → 3	Q _{Nn} value air ^{1.)} 1 → 2	Q _{Nn} value air ^{1.)} 2 → 3	Pressure range ^{2.)} [bar]	Voltage/Frequency [V/Hz]	Power rating [W]	Article no. with connection pins
		[mm]	[mm]	[l/min]	[l/min]				
C, solenoid valve 3/2 way Direct-acting Normally closed 	Bürkert Cartridge connection	0.5	0.65	6	9.55	Vac...9	12/DC	0.7	273612 ☒
						Vac...9	24/DC		272893 ☒
						2.5...10	24/DC		281022 ☒
		0.8	1.1	16	20	Vac...7.5	24/DC	2.8/0.3 ^{3.)}	285701 ☒
		1.0	1.1	20	20	Vac...5			285700 ☒
		1.2	1.1	25	22	Vac...1.5		272894 ☒	
D, solenoid valve 3/2 way Direct-acting Normally open 	Bürkert Cartridge connection	0.65	0.5	6.5	6	Vac...6	12/DC	0.7	273615 ☒
							24/DC	0.7	273614 ☒
T, solenoid valve 3/2 way Direct-acting Flow direction optional Normally closed 	Bürkert Cartridge connection	0.5	0.65	6	6	Vac...4	24/DC	0.7	292608 ☒

1.) Measurement at +20 °C, 6 bar pressure at the valve input and 1 bar pressure difference

2.) Technical vacuum (-0.8 bar)

3.) External power reduction electronics necessary

Explosion proof version

Note:

- BVS 16 ATEX E 088 X
II 2G Ex ib IIC T6...T4 Gb & II 2D Ex ib IIIB T155 °C Db
- IECEx BVS 16.0053 X
Ex ib IIC T6...T4 Gb & Ex ib IIIB T155 °C Db

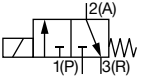
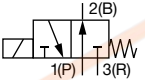
Circuit functions	Port connection	Orifice ventilation 1 → 2	Orifice ventilation 2 → 3	Q _{Nn} value air ^{1.)} 1 → 2	Q _{Nn} value air ^{1.)} 2 → 3	Pressure range ^{2.)}	Resist-ance at 20 °C ± 4 %	Min. holding current	Article no. with connection pins
		[mm]	[mm]	[l/min]	[l/min]		[Ω]		
C, solenoid valve 3/2 way Direct-acting Normally closed 	Bürkert Cartridge connection	0.5	0.65	6	9.5	Vac...6	320	29	289027
								510	23
D, solenoid valve 3/2 way Direct-acting Normally open 	Bürkert Cartridge connection	0.65	0.5	6.5	6	Vac...4	320	29	auf Anfrage

1.) Measurement at +20 °C, 6 bar pressure at the valve input and 1 bar pressure difference

2.) Technical vacuum (-0.8 bar)

Further versions on request	
Additional Leads version up to 300 mm	Voltage Voltages 9 V, 6 V, 3 V
Approval Oxygen compatibility: Suitable for the oxygen application labeled with a blue sticker	

DTS 1000257619 EN Version: M Status: RL (released | freigegeben | validé) printed: 17.09.2020



9.4. Ordering chart accessories

Single manifold fully sunken

Ordering information and dimensions of the single manifold fully sunken can be found in chapter "8.1. Single manifold fully sunken" on page 12.

Further accessories

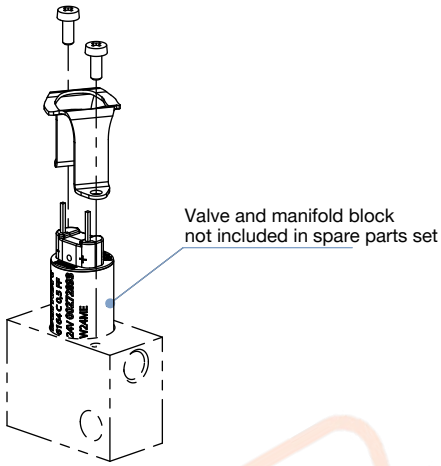
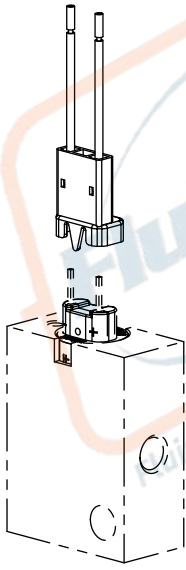
Accessories	Description	Article no.
	Mounting bracket set for semi-recessed mounting for type 6164 Scope of delivery: <ul style="list-style-type: none"> • 2 x fixing screws; M1.6x5; stainless steel A2 • 1 x mounting bracket; 1.4310 	696032 𠄎
	Plug for Type 6164 with two PVC wires; AWG 24; length 300 mm	695951 𠄎

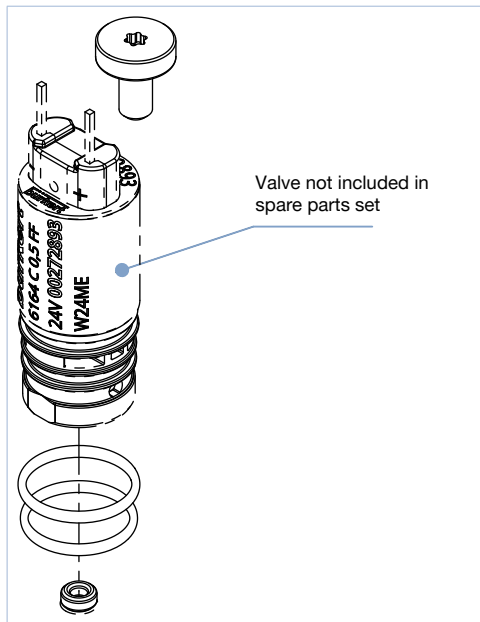
	<p>Spare parts set for Type 6164</p> <p>Scope of delivery:</p> <ul style="list-style-type: none"> • 1 x cheese head screw with internal TORX T8; M2.5x5; stainless steel A2 • 2 x O-ring large; FKM • 1 x O-ring small; FKM 	<p>696033 𠄎</p>
---	---	-----------------

DTS 1000257619 EN Version: M Status: RL (released | freigegeben | validé) printed: 17.09.2020

