



## Direct-acting 2-way low differential pressure solenoid control valve

- For high flow rates with low inlet pressure
- Direct-acting, normally closed
- Operating pressure 0 ... 0.7 bar
- Orifice sizes 8 ... 12 mm
- Port connection 1/2" and 3/4"



Product variants described in the data sheet may differ from the product presentation and description.

### Can be combined with

	<b>Type 8605</b> ▶ PWM control electronics for electromagnetic proportional valves
	<b>Type 2518</b> ▶ Cable Plug DIN EN 175301-803 - Form A
	<b>Type 8611</b> ▶ eCONTROL - Universal controller

### Type description

The direct-acting proportional valve Type 6024 works as an electromagnetically actuated control valve with relatively high flow rates at low operating pressures. The valve is normally closed.

## Table of contents

<b>1. General Technical Data</b>	<b>3</b>
<b>2. Circuit functions</b>	<b>3</b>
<b>3. Materials</b>	<b>4</b>
3.1. Chemical Resistance Chart – Bürkert resistApp.....	4
<b>4. Dimensions</b>	<b>4</b>
4.1. Brass version with coil size 8.....	4
4.2. Brass version with coil size K.....	5
4.3. Stainless steel version with coil size 8.....	6
4.4. Stainless steel version with coil size K.....	7
<b>5. Performance specifications</b>	<b>8</b>
5.1. Flow characteristic.....	8
Determination of the $K_v$ value.....	8
5.2. Exemplary characteristic curve of a proportional valve.....	8
<b>6. Ordering information</b>	<b>8</b>
6.1. Bürkert eShop – Easy ordering and quick delivery.....	9
6.2. Recommendation regarding product selection.....	9
6.3. Bürkert product filter.....	9
6.4. Ordering chart.....	9
6.5. Ordering chart accessories.....	10
Cable plug Type 2518, Form A according to DIN EN 175301 - 803.....	10
Control unit Type 8605.....	10

## 1. General Technical Data

Product properties	
Dimensions	Detailed information can be found in chapter "4. Dimensions" on page 4.
Material	
Body	Brass, stainless steel
Seal	FKM, others on request
Performance data	
Typical values of positioning behaviour <sup>1.)</sup>	
Hysteresis	< 7%
Reproducibility	< 0.5% of end value <sup>2.)</sup>
Response sensitivity	< 0.5% of end value <sup>2.)</sup>
Setting range	1:25
K <sub>v</sub> value <sup>3.)</sup>	1.4...2.8 m <sup>3</sup> /h
Maximum operating pressure <sup>4.)</sup>	0.1...0.7 bar (depending on DN)
Nominal operating mode	100 % continuous operation
Electrical data	
Operating voltage	24 V DC (12 V on request)
Power consumption	18 W
Maximum coil current <sup>5.)</sup>	620 mA
PWM frequency <sup>6.)</sup>	280 Hz
Medium data	
Operating medium	Neutral gases, liquids
Medium temperature	- 10 °C... +90 °C
Viscosity	Maximum 21 mm <sup>2</sup> /s (21 cSt)
Process/Port connection & communication	
Port connection size	G ½, G ¾ (NPT ½ and NPT ¾ on request)
Electrical connection	Cable plug Type 2518 acc. to DIN EN 175301 - 803 form A Detailed information can be found in chapter "Cable plug Type 2518, Form A according to DIN EN 175301 - 803" on page 10.
Approvals and certificates	
Degree of protection	IP65
Environment and installation	
Installation position	Any, preferably actuator face up
Ambient temperature	Maximum +55 °C

1.) Characteristic data of control behaviour depends on process conditions.

2.) By flow measurement

3.) K<sub>vs</sub> value: Flow rate value for water

4.) Pressure data: Overpressure with respect to atmospheric pressure, depending on nominal diameter, tightness seal or nominal pressure

5.) Maximum value: value depends on operating pressure

6.) PWM: pulse width modulation

## 2. Circuit functions

Circuit functions	Description
	<b>Type: A, proportional control valve</b> 2/2 way Direct-acting Normally closed

### 3. Materials

#### 3.1. Chemical Resistance Chart – Bürkert resistApp



#### Bürkert resistApp – Chemical Resistance Chart

You want to ensure the reliability and durability of the materials in your individual application case? Verify your combination of media and materials on our website or in our resistApp.

[Start Chemical Resistance Check](#)

### 4. Dimensions

#### 4.1. Brass version with coil size 8

**Note:**

Dimensions in mm

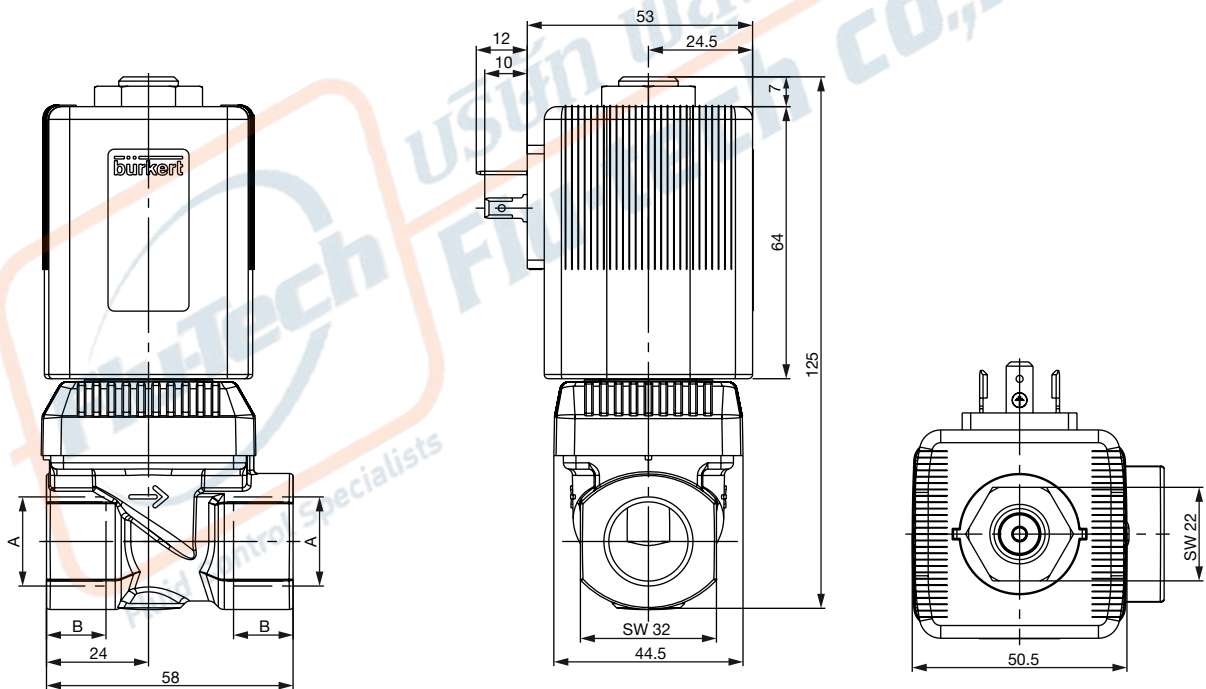

Port connection	A	B
G 1/2	G 1/2	14
NPT 1/2 (on request)	NPT 1/2	14
G 3/4	G 3/4	16
NPT 3/4 (on request)	NPT 3/4	16

DTS 1000017535 EN Version: O Status: RL (released | freigegeben | valide) printed: 05.02.2021

4.2. Brass version with coil size K

**Note:**

Dimensions in mm

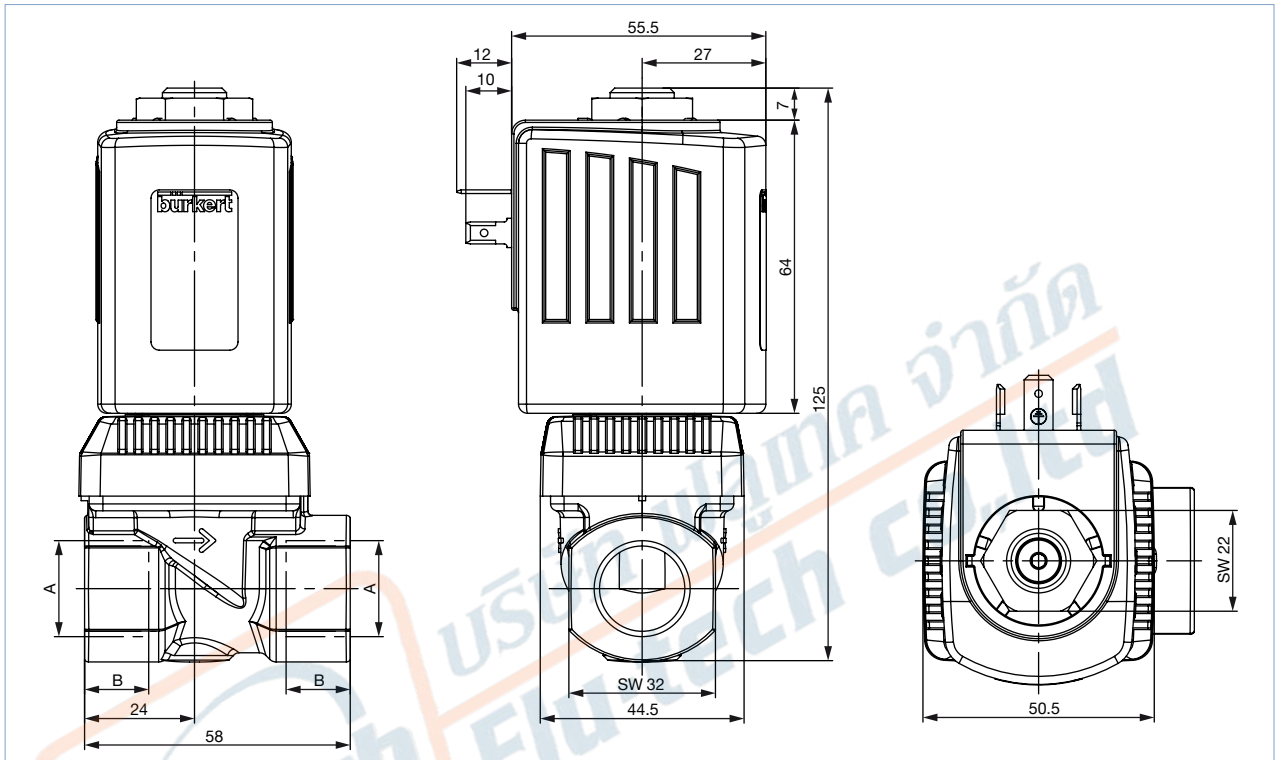

Port connection	A	B
G 1/2	G 1/2	14
NPT 1/2 (on request)	NPT 1/2	14
G 3/4	G 3/4	16
NPT 3/4 (on request)	NPT 3/4	16

DTS 1000017535 EN Version: O Status: RL (released | freigegeben | valide) printed: 05.02.2021

4.3. Stainless steel version with coil size 8

Note:

Dimensions in mm

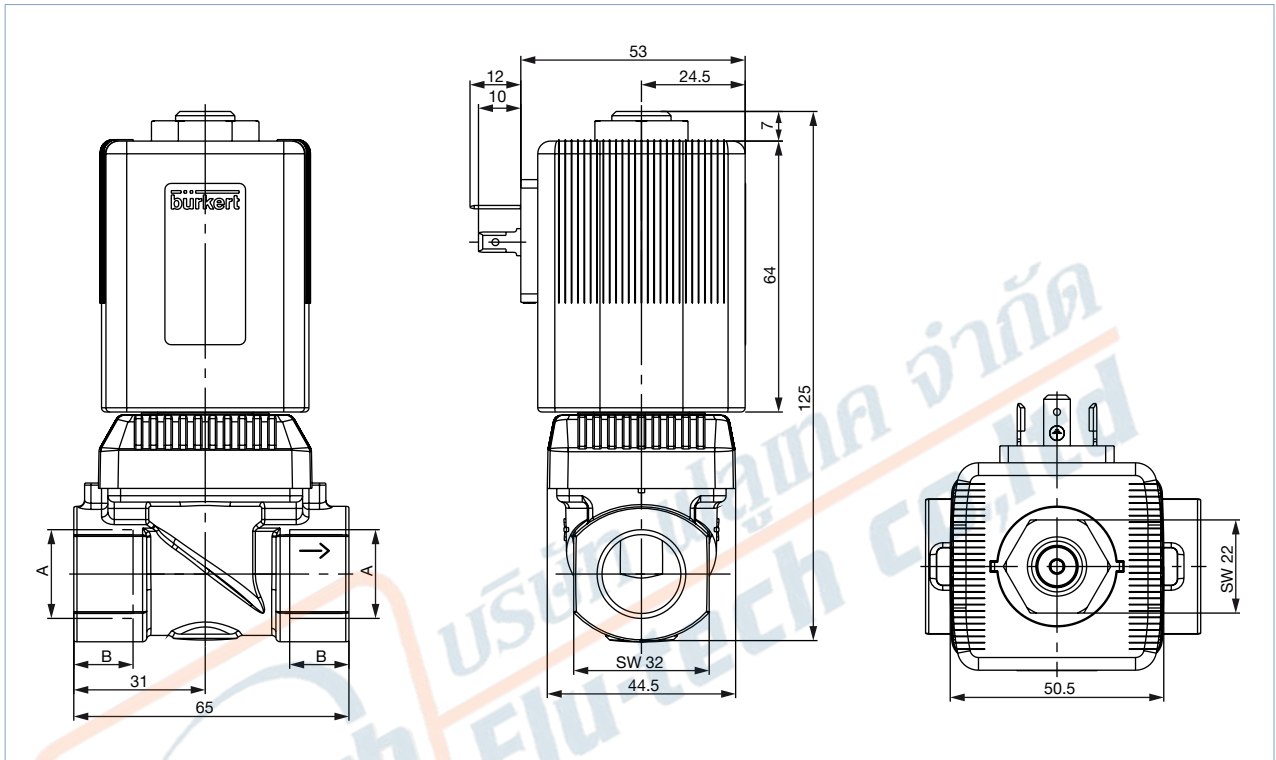

Port connection	A	B
G ½	G ½	14
NPT ½ (on request)	NPT ½	14
G ¾	G ¾	16
NPT ¾ (on request)	NPT ¾	16

DTS 1000017535 EN Version: O Status: RL (released | freigegeben | validé) printed: 05.02.2021

## 4.4. Stainless steel version with coil size K

**Note:**

Dimensions in mm

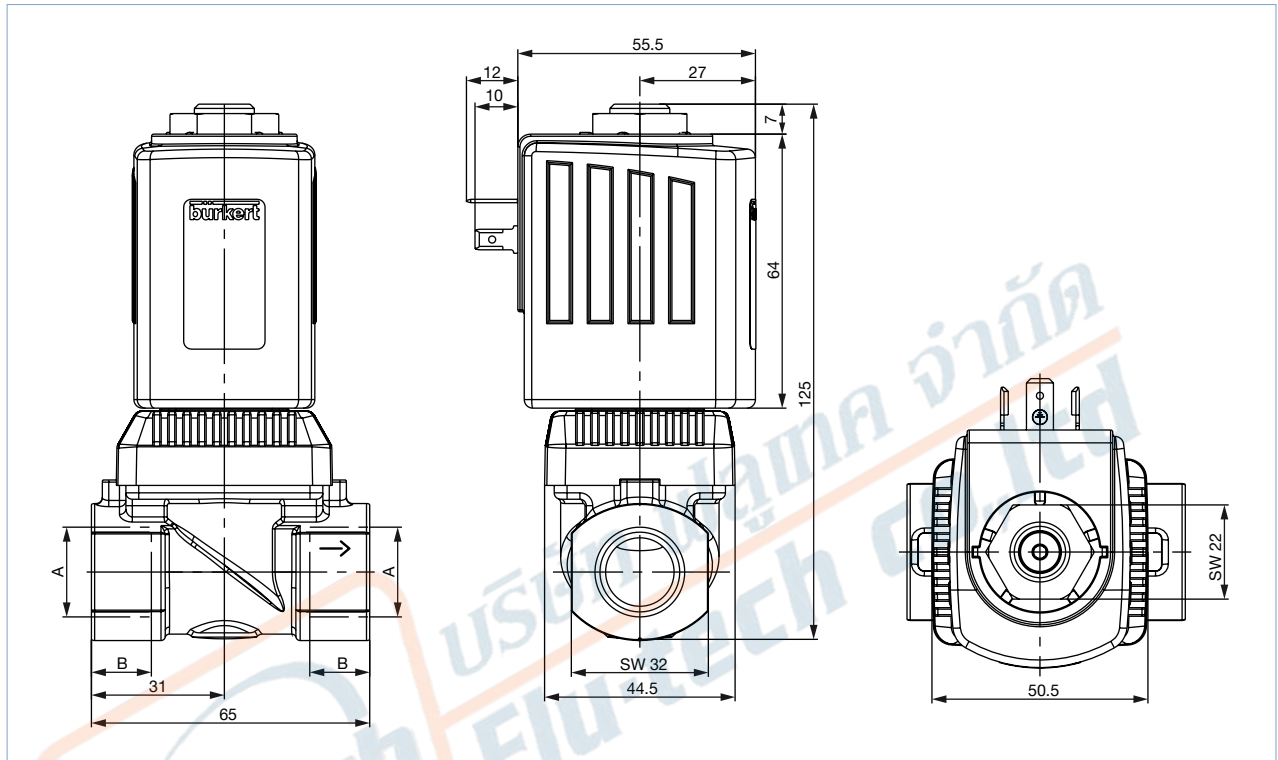

Port connection	A	B
G ½	G ½	14
NPT ½ (on request)	NPT ½	14
G ¾	G ¾	16
NPT ¾ (on request)	NPT ¾	16

## 5. Performance specifications

### 5.1. Flow characteristic

#### Determination of the $K_V$ value

Pressure drop	$K_V$ value for liquids [m <sup>3</sup> /h]	$K_V$ value for gases [m <sup>3</sup> /h]
<b>Sub-critical</b> $p_2 > \frac{p_1}{2}$	$= Q \sqrt{\frac{\rho}{1000 \Delta p}}$	$= \frac{Q_N}{514} \sqrt{\frac{T_1 \rho_N}{p_2 \Delta p}}$
<b>Supercritical</b> $p_2 < \frac{p_1}{2}$	$= Q \sqrt{\frac{\rho}{1000 \Delta p}}$	$= \frac{Q_N}{257 p_1} \sqrt{T_1 \rho_N}$

$K_V$ Flow coefficient	[m <sup>3</sup> /h] <sup>1/2</sup>
$Q_N$ Standard flow rate	[m <sup>3</sup> /h] <sup>2/3</sup>
$p_1$ Inlet pressure	[bar] <sup>3/2</sup>
$p_2$ Outlet pressure	[bar] <sup>3/2</sup>
$\Delta p$ Differential pressure $p_1 - p_2$	[bar]
$\rho$ Density	[kg/m <sup>3</sup> ]
$\rho_N$ Standard density	[kg/m <sup>3</sup> ]
$T_1$ Medium temperature	[(273+t)K]

- 1.) Measured for water,  $\Delta p = 1$  bar, over the value
- 2.) At reference conditions 1.013 bar and 0 °C (273 K)
- 3.) Absolute pressure

### 5.2. Exemplary characteristic curve of a proportional valve

#### Note:

In continuous flow applications, the choice of an appropriate valve size is much more important than with on/off valves. The optimum size should be selected such that the resulting flow in the system is not unnecessarily reduced by the valve. However, a sufficient part of the pressure drop should be taken across the valve even when it is fully opened.

Recommended value:  $\Delta p_{\text{valve}} > 25\%$  of total pressure drop within the system

Otherwise, an ideal, linear valve characteristic is deformed into a curved system characteristic.

If the differential pressure (difference between inlet and outlet pressure) exceeds half the value of the nominal pressure discontinuities may occur.

For that reason take advantage of Bürkert competent engineering services during the planning phase!

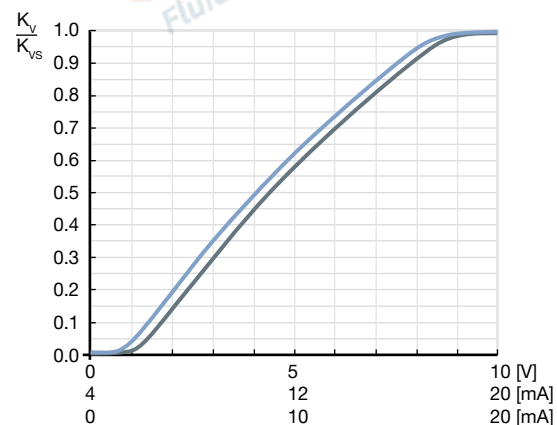



## 6. Ordering information

### 6.1. Bürkert eShop – Easy ordering and quick delivery



**Bürkert eShop – Easy ordering and fast delivery**

You want to find your desired Bürkert product or spare part quickly and order directly? Our online shop is available for you 24/7. Sign up and enjoy all the benefits.

Order online now

### 6.2. Recommendation regarding product selection

**Note:**

- Please use the “**Product Inquiry Form**” at the end of this data sheet for the specifications of the device configuration and send us a copy of the inquiry with information about the application.
- Please note the chapter “**5.2. Exemplary characteristic curve of a proportional valve**” on page 8 of product selection.

### 6.3. Bürkert product filter



**Bürkert product filter – Get quickly to the right product**

You want to select products comfortably based on your technical requirements? Use the Bürkert product filter and find suitable articles for your application quickly and easily.

Try out our product filter

### 6.4. Ordering chart

**Note:**

- All valves with FKM seal
- Please note that the cable plug must be ordered separately, see “**Cable plug Type 2518, Form A according to DIN EN 175301-803**” on page 10 or separate data sheet for **Type 2518** ▶.

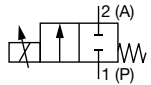
Circuit function	Orifice	Port connection	K <sub>vs</sub> value water <sup>1.)</sup>	Maximum pressure <sup>2.)</sup>	Coil power	Maximum coil current	Article no. brass body	Article no. stainless steel body
	[mm]							
<b>A, proportional control valve</b> 2/2 way Direct-acting Normally closed 	8	G ½	1.4	0.7	18	620	150401 ☒	–
		G ¾	1.4	0.7	18	620	150427 ☒	–
	10	G ½	2.0	0.4	18	620	150402 ☒	150404 ☒
		G ¾	2.0	0.4	18	620	150428 ☒	150429 ☒
	12	G ½	2.8	0.2	18	620	–	150426 ☒
		G ¾	2.8	0.2	18	620	150406 ☒	150408 ☒

1.) Flow rate value for water, measured at +20 °C and 1 bar pressure differential over a fully opened valve  
 2.) Pressure data: Overpressure with respect to atmospheric pressure

## 6.5. Ordering chart accessories

## Cable plug Type 2518, Form A according to DIN EN 175301 - 803

## Note:



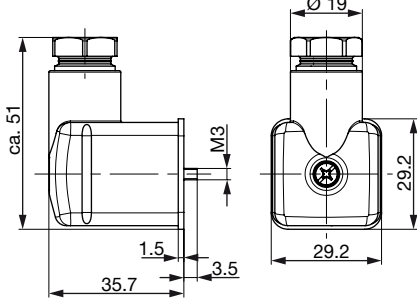









Further versions see data sheet **Type 2518** ▶.

Cable plug	Dimensions	Version	Voltage	Article no.
		Without circuitry (AC/DC)	0...250 V AC/DC	314802

## Control unit Type 8605

## Note:

Further versions see data sheet **Type 8605** ▶.

Control unit	Version	Max. coil current range [mA]	Type 6024		Article no.
			24 V DC	12 V DC	
	Cable plug with PG cable gland	200...1000	x	–	316530 
	Cable plug with M12 connection	200...1000	x	–	316528 
	Cable plug with PG cable gland	500...2000	x	x	316529 
	Cable plug with M12 connection	500...2000	x	x	316526 
	Cable plug with PG cable gland without operating element	200...1000	x	–	316521 
	Cable plug with M12 connection without operating element	200...1000	x	–	316522 
	Cable plug with PG cable gland without operating element	500...2000	x	x	316523 
	Cable plug with M12 connection without operating element	500...2000	x	x	316525 
	Standard rail	200...1000	x	–	316532 
	Standard rail	500...2000	x	x	316533 

x: on request