





2/2 way diaphragm valve with (Positioner) electric linear actuator (Type EVA)

- Safety position through energy storage
- Adjustable driving force
- Diagnostic functions and fieldbus connection
- Surfaces in contact with the product from Ra ≤ 0.38 µm...1.6 µm (optionally electropolished)
- Available in connection sizes DN 06...DN 40



Product variants described in the data sheet may differ from the product presentation and description.

Can be combined with

	Type 3323 2/2 way diaphragm valve with (ON/OFF) electric linear actuator (Type EVA)	▶
	Type 3361 Electromotive 2 way globe control valve	▶
	Type 8098 FLOWave SAW flow-meter	▶

Type description

The externally controlled diaphragm valve Type 3363 consists of an electrically controlled linear actuator (positioner), of a diaphragm and a 2 way valve housing. The electric actuator with recirculating ball screw ensures use under hygienic or aggressive environmental conditions. The flow-favorable and dead space-free valve housings enable high flow values and a wide range of possible uses. In the event of a power failure, the safety position is guaranteed by an optional energy storage device. The position is displayed by means of a 360° LED light ring. To protect the diaphragm the actuator has a drive force adjustment. A correspondingly high IP protection IP65/IP67 ensures adequate splash protection. In addition to a fast actuating speed of 1.5 to 4.5 seconds, the actuator is also equipped with a mechanical position indicator and a corresponding explosion protection ATEX/II 3G Ex ec IIC T4 Gc/II 3D Ex tc IIIC T135 °C Dc.

Table of contents

1. General technical data	3
2. Approvals	5
3. Materials	6
3.1. Chemical Resistance Chart – Bürkert resistApp.....	6
3.2. Pressure temperature diagram for plastic body.....	6
3.3. Material specifications.....	7
3.4. Example of available membrane materials.....	7
4. Dimensions	8
4.1. Actuator.....	8
4.2. Forged body (VS) with welded connection.....	9
4.3. Forged body (VS) with clamp connection.....	11
4.4. Tube valve body (VP) with welded connection.....	12
4.5. Tube valve body (VP) with clamp connection.....	13
4.6. Tube valve body (VP) with threaded connection.....	14
4.7. Tube valve body (VP) with flange connection.....	15
4.8. Cast body (VG) with welded connection.....	16
4.9. Cast body (VG) with clamp connection.....	18
4.10. Plastic body (PV; PD; PP) with spigot connections.....	19
4.11. Plastic body (PV, PD, PP) with true union.....	20
4.12. Plastic body (PV, PD, PP) with flange connection.....	21
5. Performance specifications	21
5.1. Fluidic data.....	21
Flow characteristics.....	21
5.2. Operating limits.....	22
Medium pressure.....	22
Operating limits for ambient and medium temperature.....	23
5.3. Electrical control and interfaces.....	23
Interface diagram.....	23
6. Product design and assembly	24
6.1. Product features.....	24
6.2. Product assembly.....	26
7. Ordering information	27
7.1. Bürkert eShop – Easy ordering and quick delivery.....	27
7.2. Bürkert product filter.....	27
7.3. Ordering chart accessories.....	27
7.4. Bürkert product enquiry form.....	28

1. General technical data

Product properties	
Dimensions	Detailed information can be found in chapter "4. Dimensions" on page 8.
Material	
Forged body (VS) ^{1,3}	Forged stainless steel 316L/1.4435/BN2, Fe <0.5 %/C ≤0.03 %
Tube valve body (VP) ^{1,3}	Stainless steel 316L/1.4435/BN2
Cast body (VG) ^{1,3}	Cast stainless steel 316L/1.4435
Plastic body (PV; PD; PP) ^{1,3}	PVC (PVC-U); PVDF; PP
Diaphragm	EPDM (AD) ^{1,3} , PTFE/EPDM (EA) ^{1,3} , advanced PTFE/EPDM (EU) ^{1,3} , Gylon®/EPDM laminated (ER) ^{1,3}
Design	Diaphragm control valve
Diaphragm size	8...40; for plastic body 15...40
Standard surface quality^{2,3}	
Forged body (VS) ^{1,3}	Internal electrically polished: Ra ≤0.38 µm (NO17) ^{1,3} (ASME BPE SF4/DIN HE4) (external forged surface electrically polished) Internal mechanically polished: Ra ≤0.5 µm (NO14) ^{1,3} (ASME BPE SF1) (external forged surface)
Tube valve body (VP) ^{1,3}	Internal electrically polished: Ra ≤0.38 µm (NO17) ^{1,3} (ASME BPE SF4/DIN HE4) External glass bead blasted: Ra ≤1.6 µm (NO01) ^{1,3} Internal glass bead blasted: Ra ≤1.6 µm (NO05) ^{1,3}
Cast body (VG) ^{1,3}	Internal electrically polished: Ra ≤0.6 µm (NO16) ^{1,3} (ASME BPE SF6) (external cast surface electrically polished) Internal mechanically polished: Ra ≤0.76 µm (NO06) ^{1,3} (ASME BPE SF3/DIN H2) (external cast surface)
Safety setting in case of power failure	With SAFEPOS energy-pack: open, closed or freely programmable Without SAFEPOS energy-pack: blocked in last position
Lifelong energy storage SAFEPOS energy-pack	Up to 10 years (depending on operating conditions)
Controller version	Positioner or process controller (optional)
Performance data	
Closing time	< 1.5...4.5 s. depending on diaphragm size
Traverse speed	4 mm/s
Dead band of the positioner	±0.4 %
Electrical data	
Operating voltage	24 V DC ± 10 % (max. residual ripple 10 %)
Operating current ^{3,4}	Max. 3 A (at max. load and including 1 A charging current of the optional SAFEPOS energy-pack)
Protection class (DIN EN 61140)	3
Duty cycle	100 %
Standby consumption ^{3,4}	2...5 W
Communication and control	
Norm signal (analogue)	Setpoint value: 0/4...20 mA, 0...5/10 V and binary input (further inputs & outputs optional, see "5.2. Electrical control unit and interface" on page 13)
Feldbus (digital)	Bürkert-Systembus (bÜS) CANopen (Option) EtherNet/IP, PROFINET, Modbus/TCP (Option über integriertes Gateway)
Medium data	
Process medium	Neutral gases and fluids, highly purified, sterile, aggressive or abrasive medium (see chemical resistance chart ▶)
Medium temperature	
EPDM (AD) ^{1,3}	-10...+143 °C (steam sterilisation + 150 °C for 60 min)
PTFE/EPDM (EA) ^{1,3}	-10...+130 °C (steam sterilisation + 140 °C for 60 min)
Advanced PTFE/EPDM (EU) ^{1,3}	-5...+143 °C (steam sterilisation + 150 °C for 60 min)
GYLON®/EPDM laminated (ER) ^{1,3}	-5...+130 °C (steam sterilisation + 140 °C for 60 min)
Plastic body	See "3.2. Pressure temperature diagram for plastic body" on page 6

Process/Port connection & communication

Port connection size	DN 06...DN 40 (1/8" ... 1 1/2")
----------------------	---------------------------------

Port connection^{2.)}**For stainless steel body^{4.)}**

Welded connection ^{2.)}	DIN EN ISO 1127/ISO 4200/DIN 11866 series B DIN 11850 series 2/DIN 11866 series A/DIN EN 10357 series A ASME BPE/DIN 11866 series C
----------------------------------	---

Clamp connection ^{2.)}	DIN 32676 series A (DIN pipe) DIN 32676 series B (ISO pipe) ASME BPE
---------------------------------	--

For plastic body

Spigot connection	DN 15...DN 40
True union	DN 15...DN 40
Loose flange	DN 15...DN 40

Electrical connection

Actuator	Terminal strip with cable gland, 2 x M20 or 2 M12 circular plugs, 5 pin and 8 pin
Fieldbus gateway	2 M12 circular sockets, 4 pin (only with Industrial Ethernets)

Approvals and certificates

Ignition protection class	II 3G Ex ec IIC T4 Gc II 3D Ex tc IIIC T135 °C Dc
---------------------------	--

Environment and installation

Ambient temperature	- 10 °C...+ 65°C ^{5.)} (without display) - 10 °C...+ 60°C ^{5.)} (with display) - 10 °C...+ 55°C ^{5.)} (with SAFEPOS energy storage)
Degree of protection	IP65/IP67 (DIN EN 60529), NEMA 4X

Vibration and shock resistance

Vibration, sinusoidal	5 g (IEC 60068 -2 -6 Test Fc)
Shock, mechanical	50 g (IEC 60068 -2 -27 Test Ea)
Installation position	As required, preferably with actuator upright

1.) This information is part of the product key (see Product Enquiry Form at the end of this data sheet)

2.) Further port connections on request

3.) All values refer to a supply voltage of 24 V at 25 °C.





4.) Tube valve body (VP) also available with flange and threaded connections

5.) Depending on medium temperature, see chapter "Operating limits for ambient and medium temperature" on page 23

2. Approvals

Note:

If you need one of these certificates, please contact your Bürkert partner.

Approvals/ Conformity/ Certificate ^{1.)}	Description
	ATEX/IECEx ^{2.)} BVS 17 ATEX E 117 X II 3G Ex ec IIC T4 Gc/II 3D Ex tc IIIC T135 °C Dc IECEx BVS 17.0100X Ex ec IIC T4 Gc/Ex tc IIIC T135 °C Dc
	3-A (3-A Sanitary Standards Symbol Administrative Council) ^{3.)}
	The diaphragms made of EPDM (AD), PTFE/EPDM (EA), advanced PTFE/EPDM (EU) and GYLON®/EPDM laminated (ER) are suitable for use with food and beverages (acc. to EC Regulation 1935/2004/EC).
	Diaphragms made of EPDM (AD), PTFE/EPDM (EA), advanced PTFE/EPDM (EU) and GYLON®/EPDM laminated (ER) are acc. to USP Class VI tested.
FDA	Diaphragms made of EPDM (AD), PTFE/EPDM (EA), advanced PTFE/EPDM (EU) and GYLON®/EPDM laminated (ER) comply with the Code of Federal Regulations published by the FDA (Food and Drug Administration, USA).
	Safety requirements UL-listed cULus Cert. No. 238179 (optional)

1.) Further approvals/conformity clarification on request

2.) Only in combination with variable code «PX48» (see Product Enquiry Form at the end of this data sheet)

3.) Only in combination with variable code «PE05» (see Product Enquiry Form at the end of this data sheet)

3. Materials

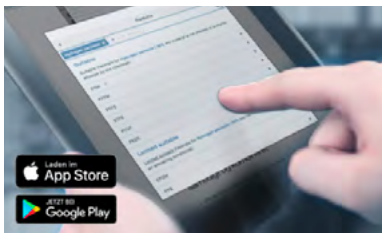

3.1. Chemical Resistance Chart – Bürkert resistApp



Bürkert resistApp – Chemical Resistance Chart

You want to ensure the reliability and durability of the materials in your individual application case? Verify your combination of media and materials on our website or in our resistApp.

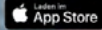
Start Chemical Resistance Check

3.2. Pressure temperature diagram for plastic body

Note:

This information is important for material selection. Observe the permissible operating pressure depending on the medium temperature.

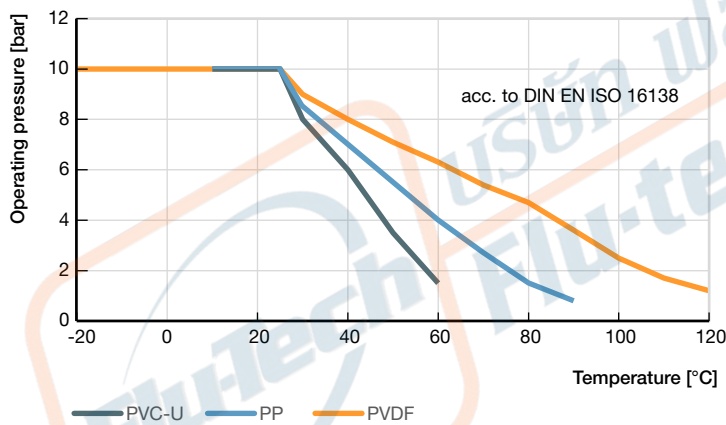

DTS 1000303711 EN Version: M Status: RL (released | freigegeben | validé) printed: 01.06.2022

3.3. Material specifications

Note:

The depiction of the products may differ from the actual specific design (e.g. body material, and port connection).

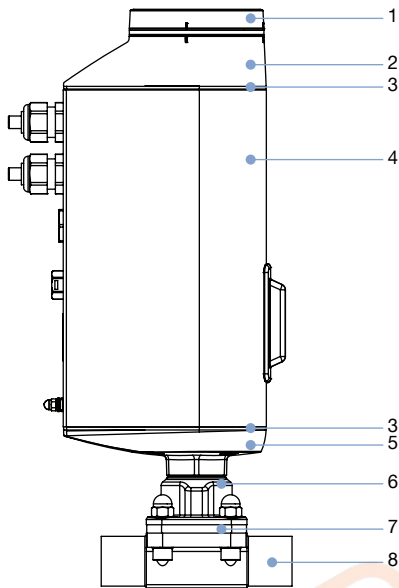

No.	Element	Material
1	Display housing/ Blind cover	<ul style="list-style-type: none"> PPS (standard) Stainless steel 1.4301 (for ATEX/IECEX)
2	Actuator cover	PPS
3	Seal	EPDM
4	Actuator housing	Aluminium powder coated
5	Actuator base	PPS
6	Interface	Stainless steel 1.4308
7	Diaphragm	<ul style="list-style-type: none"> EPDM (AD) PTFE/EPDM (EA) Advanced PTFE/EPDM (EU) Gylon(R)/EPDM laminated (ER)
8	Valve body	See "1. General technical data" on page 3

3.4. Example of available membrane materials

The diaphragms have been developed to meet the unique challenges of hygienic and sterile requirements. Bürkert offers diaphragms with precise material composition and high accuracy. Bürkert diaphragms are available in a wide range of materials which have been tested and proven in applications in the food and beverage, biotechnology, pharmaceutical and cosmetics industries. The diaphragms are tested during development and production to ensure reliability under difficult process conditions.



- EPDM (AD)
- PTFE/EPDM (EA)
- advanced PTFE/EPDM (EU)
- Gylon®/EPDM laminated (ER)

For further information please refer to our flyer "Diaphragm competence for hygienic applications" on our [website](#) ►.

4. Dimensions

4.1. Actuator

Note:

Dimensions in mm, unless otherwise stated

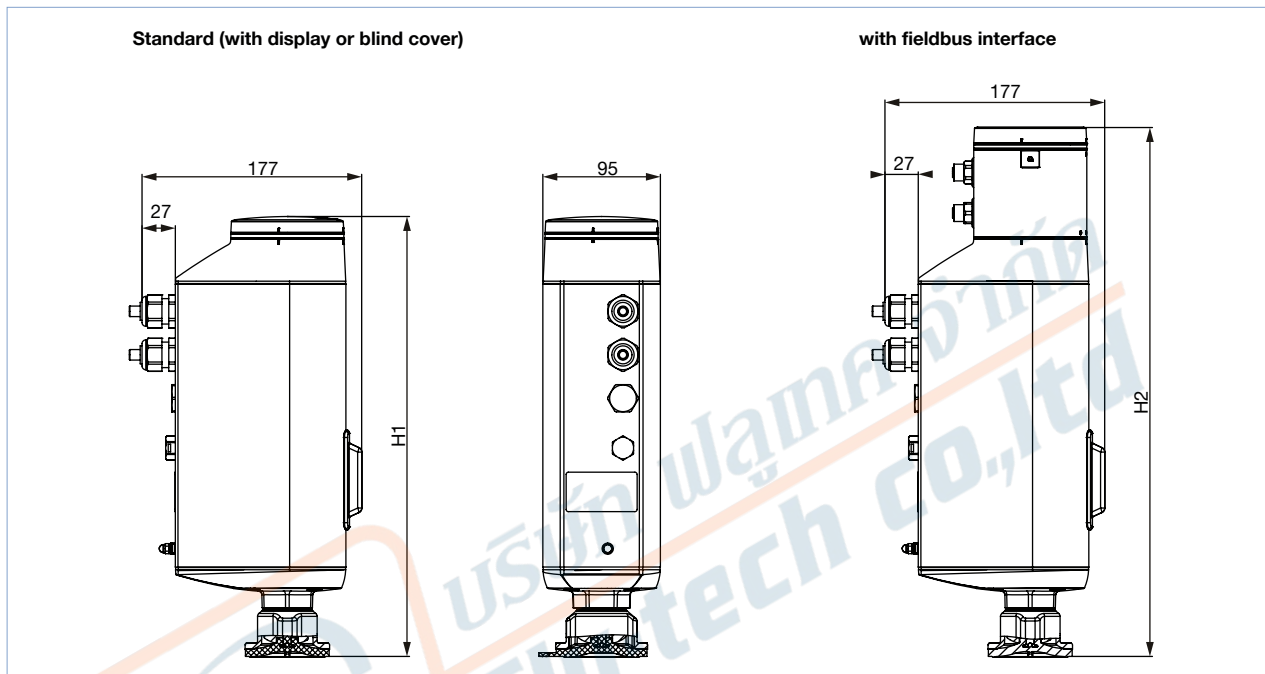

Diaphragm size	Height	
	H1 [mm]	H2 [mm]
8	342	414
15	345	418
20	350	422
25	355	426
32	365	436
40	370	442

DTS 1000303711 EN Version: M Status: RL (released | freigegeben | validé) printed: 01.06.2022

4.2. Forged body (VS) with welded connection

Note:

- Dimensions in mm, unless otherwise stated
- For detailed information on the draining angle, please refer to the “Additional manual Type 2xxx 3xxx” on our website (see [operating instructions](#) ▶).

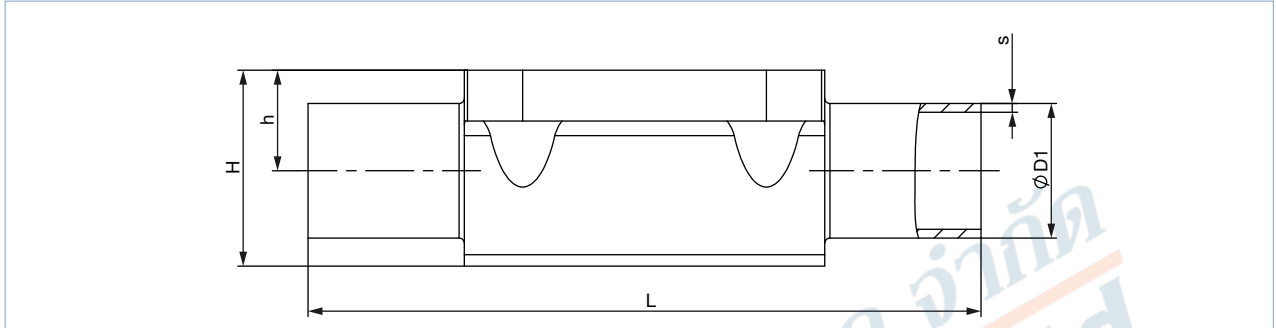

Diaphragm size	Port connection DN	ØD1	s	L	h	H	Product key ¹⁾
DIN EN ISO 1127/ISO 4200/DIN 11866 series B							
8	8	13.5	1.6	90	9.3	18.8	SA40
15	8	13.5	1.6	108	8.15	19.85	SA40
8	10	17.2	1.6	90	9.3	18.8	SA41
15	10	17.2	1.6	110	12.05	23.75	SA41
15	15	21.3	1.6	110	12.05	23.75	SA42
20	15	21.3	1.6	119	16	30.3	SA42
20	20	26.9	1.6	119	16	30.3	SA43
25	20	26.9	1.6	119	19	37	SA43
25	25	33.7	2.0	129	19	37	SA44
40	25	33.7	2.0	161	27.6	52.4	SA44
40	32	42.4	2.0	161	27.6	52.4	SA45
40	40	48.3	2.0	161	27.6	52.4	SA46
DIN 11850 series 2/DIN 11866 series A/DIN EN 10357 series A							
8	10	13	1.5	90	9.3	18.8	SD40
15	10	13	1.5	110	8.15	19.85	SD40
15	15	19	1.5	110	12.05	23.75	SD42
20	20	23	1.5	119	16.0	30.3	SD43
25	25	29	1.5	129	19.0	37.0	SD44
40	32	35	1.5	161	27.6	52.4	SD45
40	40	41	1.5	161	27.6	52.4	SD46
ASME BPE/DIN 11866 series C							
8	¼"	6.35	0.89	78	5.7	15.2	SA90
8	⅜"	9.53	0.89	89	5.7	15.2	SA91
8	½"	12.7	1.65	89	9.3	18.8	SA92
15	½"	12.7	1.65	108	8.15	19.85	SA92
15	¾"	19.05	1.65	108	12.05	23.75	SA93
20	¾"	19.05	1.65	117	16.0	30.3	SA93
25	1"	25.4	1.65	127	19.0	37.0	SODF
40	1½"	38.1	1.65	159	27.6	52.4	SODH

Diaphragm size	Port connection DN	ØD1	s	L	h	H	Product key ^{1.)}
BS 4825							
8	8	6.35	1.20	78	5.7	15.2	SODB
8	10	9.53	1.20	89	5.7	15.2	SODC
15	15	12.7	1.20	108	8.15	19.85	SODD
20	20	19.05	1.20	117	16.0	30.3	SODE
25	25	25.4	1.65	127	19.0	37.0	SODF
40	40	38.1	1.65	159	27.6	52.4	SODH
SMS 3008							
25	25	25	1.2	129	19	37	SA60
40	40	38	1.2	161	27.6	52.4	SA62
DIN 11850 series 0							
8	6	8	1.0	90	5.7	15.2	SC41
8	8	10	1.0	90	5.7	15.2	SC42

1.) This information is part of the product key (see Product Enquiry Form at the end of this data sheet)

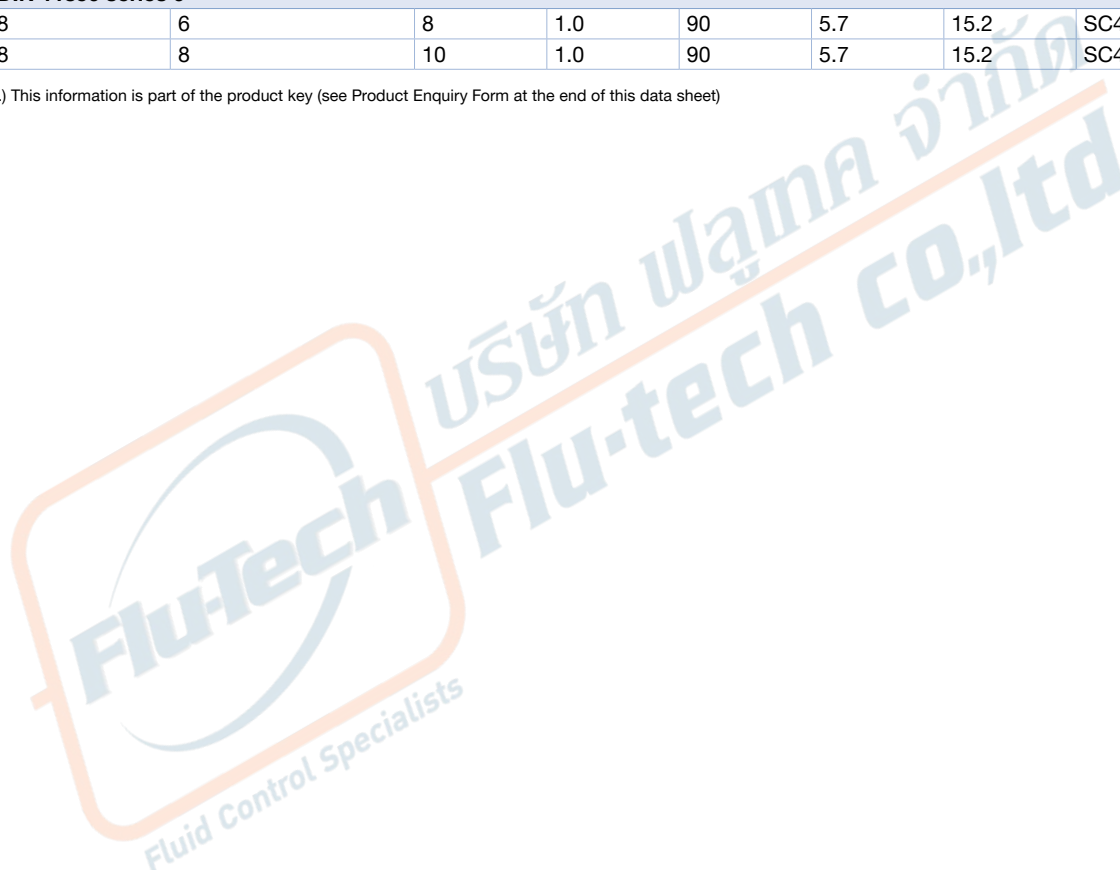

4.3. Forged body (VS) with clamp connection

Note:

- Dimensions in mm, unless otherwise stated
- For detailed information on the draining angle, please refer to the "Additional manual Type 2xxx 3xxx" on our website (see [operating instructions](#) ▶).

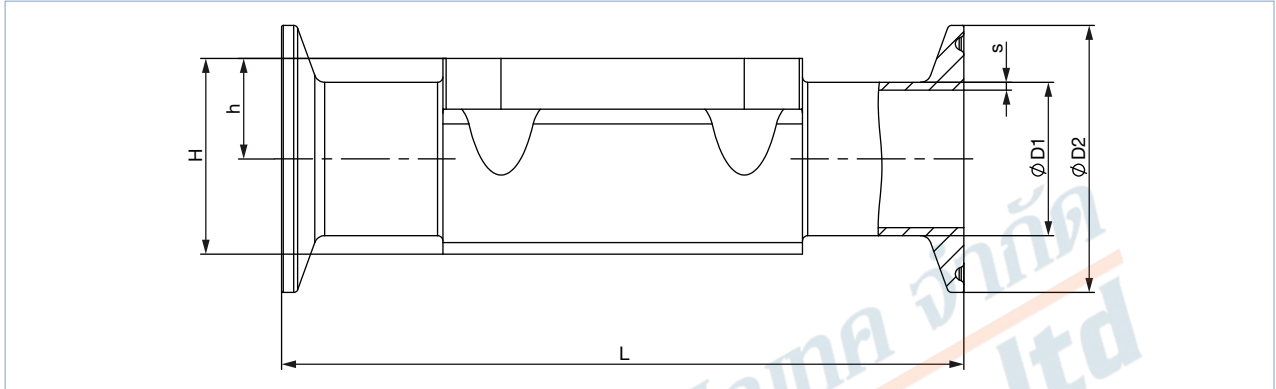

Diaphragm size	Port connection DN	ØD1	s	ØD2	L	h	H	Product key ^{1.)}	Variable code ^{1.)}
DIN 32676 series B (ISO pipe)									
15	15	21.3	1.6	50.5	167	12.05	23.75	TC53	–
20	20	26.9	1.6	50.5	114	16.0	30.3	TC43	–
25	25	33.7	2	50.5	129	19	37	TC44	–
40	40	48.3	2	64.0	161	27.6	52.4	TC46	–
DIN 32676 series A (DIN pipe)									
8	10	13	1.5	34.0	126	9.3	18.8	TD41	–
15	10	13	1.5	34.0	110	8.15	19.85	TD41	–
15	15	19	1.5	34.0	110	12.05	23.75	TD42	–
20	20	23	1.5	34.0	119	16	30.3	TD43	–
25	25	29	1.5	50.5	129	19	37	TD44	–
40	40	41	1.5	50.5	161	27.6	52.4	TD46	–
ASME BPE									
8	¼"	6.35	0.89	25.0	64.5	5.7	15.2	TG50	–
8	⅜"	9.53	0.89	25.0	89	5.7	15.2	TG01	AF34
8	½"	12.7	1.65	25.0	64	9.3	18.8	TG02	–
8	½"	12.7	1.65	25.0	89	9.3	18.8	TG02	AF34
15	½"	12.7	1.65	25.0	89	8.15	19.85	TG02	–
15	½"	12.7	1.65	25.0	108	8.15	19.85	TG02	AF34
15	¾"	19.05	1.65	25.0	89	12.05	23.75	TG03	–
20	¾"	19.05	1.65	25.0	102	16	30.3	TG03	–
20	¾"	19.05	1.65	25.0	117	16	30.3	TG03	AF34
25	1"	25.4	1.65	50.5	114	19	37	TG04	–
25	1"	25.4	1.65	50.5	127	19	37	TG04	AF34
40	1½"	38.1	1.65	50.5	140	27.6	52.4	TG05	–
40	1½"	38.1	1.65	50.5	159	27.6	52.4	TG05	AF34

1.) This information is part of the product key (see Product Enquiry Form at the end of this data sheet)

4.4. Tube valve body (VP) with welded connection

Note:

- Dimensions in mm, unless otherwise stated
- For detailed information on the draining angle, please refer to the “Additional manual Type 2xxx 3xxx” on our website (see [operating instructions](#) ▶).

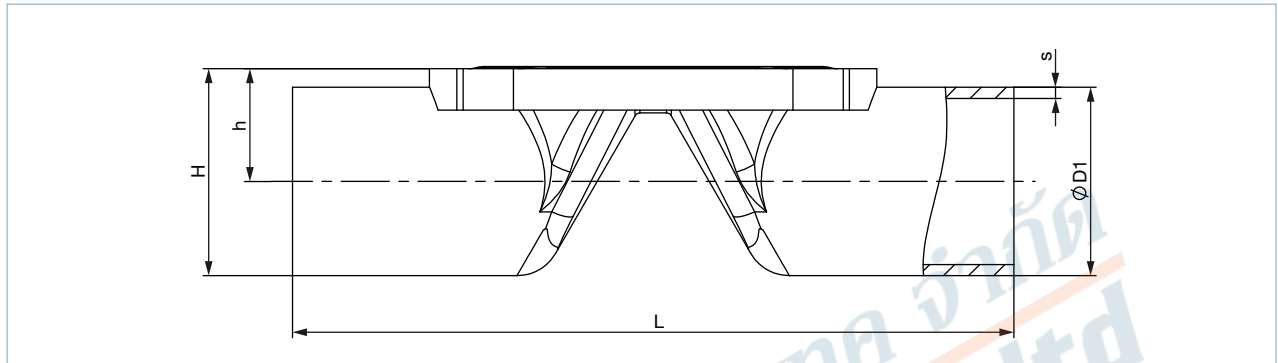

Diaphragm size	Port connection DN	ØD1	s	L	h	H	Product key ^{1.)}
DIN EN ISO 1127/ISO 4200/DIN 11866 series B							
8	8	13.5	1.6	90.0	9.85	16.6	SA40
8	10	17.2	1.6	90.0	11.70	20.3	SA41
15	15	21.3	1.6	110.0	14.35	25.0	SA42
20	20	26.6	1.6	119.0	17.15	30.45	SA43
25	25	33.7	2.0	129.0	20.55	37.4	SA44
32	32	42.4	2.0	148.0	25.10	46.3	SA45
40	40	48.3	2.0	161.0	29.35	53.5	SA46
DIN 11850 series 2/DIN 11866 series A/DIN EN 10357 series A							
8	10	13	1.5	90	9.85	16.35	SD40
15	15	19	1.5	110	13.20	22.70	SD42
15	20	23	1.5	119	15.20	26.70	SD43
20	25	29	1.5	129	18.20	32.70	SD44
25	32	35	1.5	148	21.20	38.70	SD45
32	40	41	1.5	161	24.40	44.90	SD46
40	50	53	1.5	192	31.70	58.20	SD47
ASME BPE/DIN 11866 series C							
8	½"	12.7	1.65	90.0	9.45	21.95	SA92
15	¾"	19.05	1.65	117.0	13.23	25.73	SA93
20	1"	25.4	1.65	127.0	16.40	41.65	SODF
32	1½"	38.1	1.65	159.0	22.95	48.20	SODH
40	2"	50.8	1.65	190	30.60	62.60	SODI

1.) This information is part of the product key (see Product Enquiry Form at the end of this data sheet)

4.5. Tube valve body (VP) with clamp connection

Note:

- Dimensions in mm, unless otherwise stated
- For detailed information on the draining angle, please refer to the “Additional manual Type 2xxx 3xxx” on our website (see [operating instructions](#) ▶).

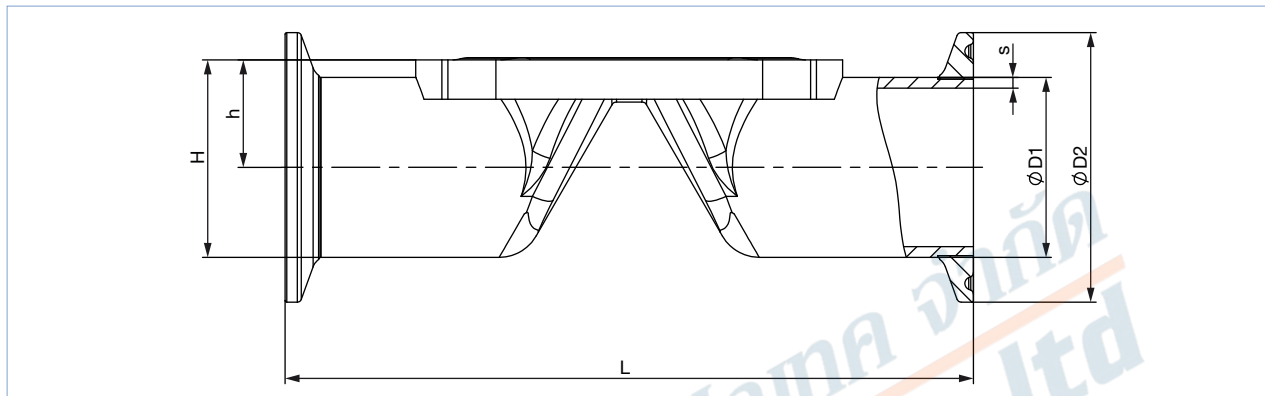

Diaphragm size	Port connection DN	ØD1	s	ØD2	L	h	H	Product key ^{1.)}
DIN 32676 series B (ISO pipe)								
8	8	13.5	1.6	25.0	89	9.85	22.35	TC40
8	10	17.2	1.6	25.0	89	11.70	24.20	TC53
15	15	21.3	1.6	50.5	110	14.35	39.60	TC52
20	20	26.6	1.6	50.5	119	17.15	42.40	TC43
25	25	33.7	2.0	50.5	129	20.55	45.80	TC44
32	32	42.4	2.0	64.0	148	25.10	57.10	TC55
40	40	48.3	2.0	64.0	161	29.35	61.35	TC46
DIN 32676 series A (DIN pipe)								
8	10	13.0	1.5	34.0	89	9.85	26.85	TD41
15	15	19.0	1.5	34.0	110	13.2	30.20	TD42
15	20	23.0	1.5	34.0	119	15.20	32.20	TD43
20	25	29.0	1.5	50.5	129	18.20	43.45	TD44
25	32	35.0	1.5	50.5	148	21.20	46.45	TD45
32	40	41.0	1.5	50.5	161	24.40	49.65	TD46
40	50	53.0	1.5	64.0	192	31.70	63.70	TD47
ASME BPE								
8	½"	12.7	1.65	25.0	89	9.45	21.95	TG02
15	¾"	19.05	1.65	25.0	102	13.20	25.73	TG03
20	1"	25.4	1.65	50.5	114	16.40	41.65	TG04
32	1½"	38.10	1.65	50.5	140	22.95	48.20	TG05
40	2"	50.80	1.65	64.0	159	30.60	62.60	TG06

1.) This information is part of the product key (see Product Enquiry Form at the end of this data sheet)

4.6. Tube valve body (VP) with threaded connection

Note:

- Dimensions in mm, unless otherwise stated
- For detailed information on the draining angle, please refer to the “Additional manual Type 2xxx 3xxx” on our website (see [operating instructions](#) ▶).

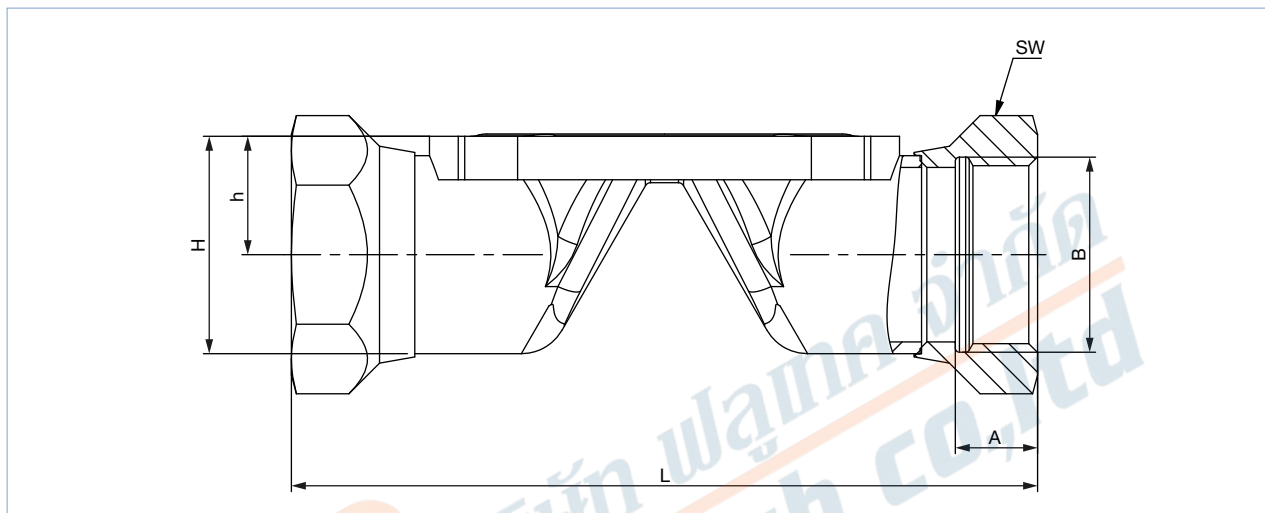

Diaphragm size	L	A	B	h	H	Spanner width of threaded ports	Product key ^{1.)}
08	85	9	G ¼	11.70	20.3	17	GM82
15	102	14	G ½	14.35	25.0	27	GM84
20	118	12	G ¾	17.15	30.45	32	GM85
25	127	14	G 1	20.55	37.4	41	GM86
32	146	16	G 1¼	25.10	46.3	50	GM87
40	159	18	G 1½	29.35	53.5	60	GM88
Diaphragm size	L	A	B	h	H	Spanner width of threaded ports	Product key ^{1.)}
08	85	9.7	Rc ¼	11.70	20.3	17	RC82
15	102	13.2	Rc ½	14.35	25.0	27	RC84
20	118	14.5	Rc ¾	17.15	30.45	32	RC85
25	127	16.8	Rc 1	20.55	37.4	41	RC86
32	146	19.1	Rc 1¼	25.10	46.3	50	RC87
40	159	19.1	Rc 1½	29.35	53.5	60	RC88
Diaphragm size	L	A	B	h	H	Spanner width of threaded ports	Product key ^{1.)}
08	85	10	NPT ¼	11.70	20.3	17	NM82
15	102	13.7	NPT ½	14.35	25.0	27	NM84
20	118	14	NPT ¾	17.15	30.45	32	NM85
25	127	16.8	NPT 1	20.55	37.4	41	NM86
32	146	17.3	NPT 1¼	25.10	46.3	50	NM87
40	159	17.3	NPT 1½	29.35	53.5	60	NM88

1.) This information is part of the product key (see Product Enquiry Form at the end of this data sheet)

4.7. Tube valve body (VP) with flange connection

Note:

- Dimensions in mm, unless otherwise stated
- For detailed information on the draining angle, please refer to the “Additional manual Type 2xxx 3xxx” on our website (see **operating instructions** ▶).

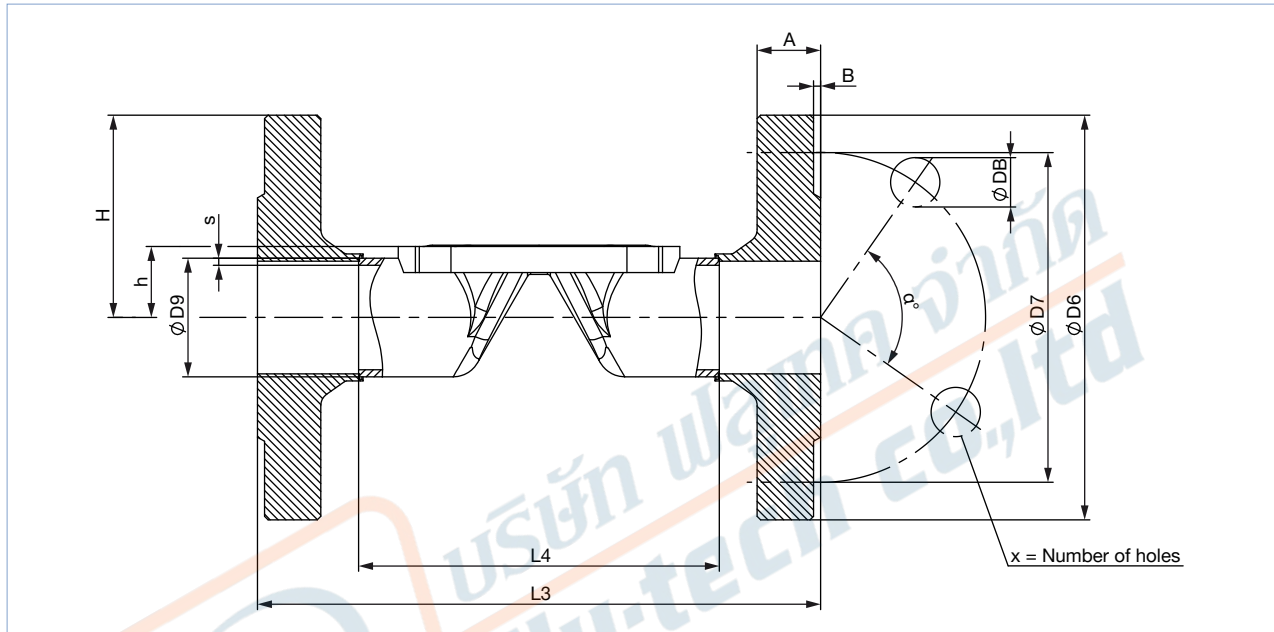

Diaphragm size	L4	L3	s3	ØD9	ØD6	ØD7	a°	ØDB	A	B	X	Product key ^{1.)}
DIN EN 1092-1												
15	76.5	130	1.6	21.3	76.5	65.0	90	14	16	2	4	FD22
20	92.5	150	1.6	26.9	92.5	75.0	90	14	18	2	4	FD23
25	102.5	160	2.0	33.7	102.5	85.0	90	14	18	2	4	FD24
32	122.5	180	2.0	42.4	122.5	100.0	90	18	18	2	4	FD25
40	136.5	200	2.0	48.3	136.5	110.0	90	18	18	3	4	FD26
ANSI B16.5												
15	67.0	130	1.6	21.3	89	60.5	90	15.7	11.2	1.6	4	FA02
25	106.0	160	2.0	33.7	108	79.2	90	15.7	14.2	1.6	4	FA04
40	128.0	200	2.0	48.3	127	98.6	90	15.7	17.5	1.6	4	FA06
JIS 10K												
15	89	130	1.6	21.3	95	70	90	15	12	1	4	FJ01
20	103	150	1.6	26.9	100	75	90	15	14	1	4	FJ02
25	116	160	2.0	33.7	125	90	90	19	14	1	4	FJ03
40	147	200	2.0	48.3	140	105	90	19	16	2	4	FJ05

1.) This information is part of the product key (see Product Enquiry Form at the end of this data sheet)

DTS 1000303711 EN Version: M Status: RL (released | freigegeben | validé) printed: 01.06.2022

4.8. Cast body (VG) with welded connection

Note:

- Dimensions in mm, unless otherwise stated
- For detailed information on the draining angle, please refer to the “Additional manual Type 2xxx 3xxx” on our website (see [operating instructions](#) ▶).

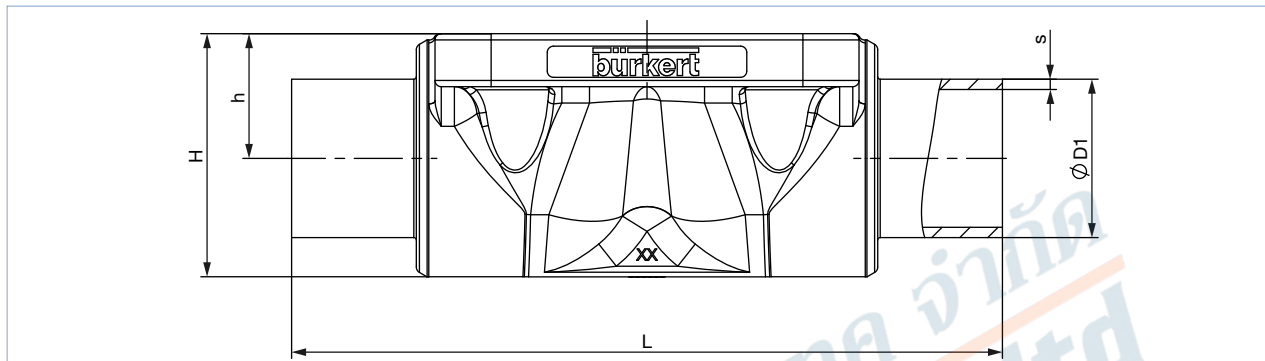

Diaphragm size	Port connection DN	ØD1	s	L	h	H	Product key ¹⁾
DIN EN ISO 1127/ISO 4200/DIN 11866 series B							
8	8	13.5	1.6	90	9.6	18.5	SA40
8	10	17.2	1.6	90	9.6	18.6	SA41
15	15	21.3	1.6	110	13.5	25.0	SA42
20	15	21.3	1.6	119	18.0	32.9	SA42
20	20	26.9	1.6	119	18.0	32.7	SA43
25	25	33.7	2.0	129	20.0	39.0	SA44
40	32	42.4	2.0	161	28.6	55.0	SA45
40	40	48.3	2.0	161	28.6	55.0	SA46
DIN 11850 series 2/DIN 11866 series A/DIN EN 10357 series A							
8	10	13	1.5	90	9.6	18.6	SD40
15	15	19	1.5	110	13.5	25.0	SD42
20	20	23	1.5	119	18.0	32.8	SD43
25	25	29	1.5	129	20.0	39.0	SD44
40	40	41	1.5	161	28.6	55.0	SD46
ASME BPE/DIN 11866 series C							
8	1/4"	6.35	0.89	64.5	9.6	18.6	SA90
8	3/8"	9.53	0.89	89	9.6	18.6	SA91
8	1/2"	12.7	1.65	89	9.6	18.6	SA92
15	3/4"	19.05	1.65	102	13.5	25.0	SA93
20	3/4"	19.05	1.65	119	18.0	32.8	SA93
20	1"	25.4	1.65	119	18.0	32.7	SODF
25	1"	25.4	1.65	114	20.0	39.0	SODF
40	1 1/2"	38.1	1.65	140	28.6	55.0	SODH

Diaphragm size	Port connection DN	ØD1	s	L	h	H	Product key ^{1.)}
BS 4825							
8	8	6.35	1.20	64.5	9.6	18.6	SODB
8	10	9.53	1.20	89	9.6	18.6	SODC
8	15	12.7	1.20	89	9.6	18.6	SODD
15	20	19.05	1.20	102	14.0	25.5	SODE
20	25	25.4	1.65	119	18.0	32.8	SODF
25	25	25.4	1.65	114	20.0	39.0	SODF
40	40	38.1	1.65	140	28.6	55.0	SODH
SMS 3008							
20	25	25	1.2	119	18.0	32.8	SA60
25	25	25	1.2	129	20.0	39.0	SA60
40	40	38	1.2	161	28.6	55.0	SA62
DIN 11850 series 0							
8	4	6	1.0	90	9.6	18.6	SC40
8	6	8	1.0	90	9.6	18.6	SC41
8	8	10	1.0	90	9.6	18.6	SC42
15	15	18	1.5	110	13.5	25.0	SC43
20	20	22	1.5	119	18.0	32.8	SC44
25	25	28	1.5	129	20.0	39.0	SC45
25	32	34	1.5	129	20.0	39.0	SC46
40	40	40	1.5	161	28.6	56.0	SC47

1.) This information is part of the product key (see Product Enquiry Form at the end of this data sheet)

4.9. Cast body (VG) with clamp connection

Note:

- Dimensions in mm, unless otherwise stated
- For detailed information on the draining angle, please refer to the “Additional manual Type 2xxx 3xxx” on our website (see [operating instructions](#) ▶).

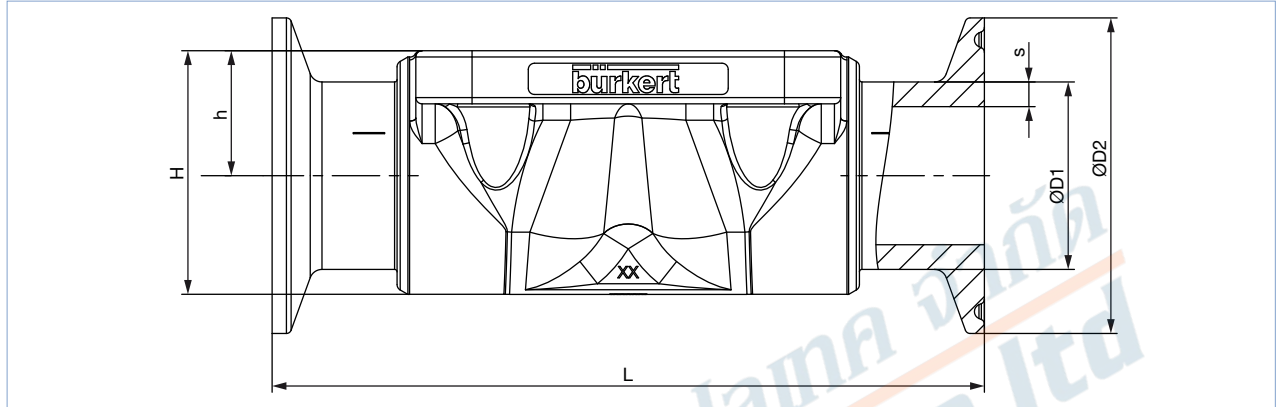

Diaphragm size	Port connection DN	ØD1	s	ØD2	L	h	H	Product key ^{1.)}
DIN 32676 series B (ISO pipe)								
25	25	33.7	2	50.5	129	20.0	39.0	TC44
40	40	48.3	2	64.0	161	28.6	55.0	TC46
DIN 32676 series A (DIN pipe)								
15	15	19	1.5	34.0	110	13.5	25.0	TD42
20	20	23	1.5	34.0	119	18.0	32.8	TD43
25	25	29	1.5	50.5	129	20.0	39.0	TD44
40	40	41	1.5	50.5	161	28.6	55.0	TD46
ASME BPE								
8	3/8"	9.53	0.89	25.0	89	9.6	18.6	TG01
8	1/2"	12.7	1.65	25.0	89	9.6	18.6	TG02
15	3/4"	19.05	1.65	25.0	102	13.5	23.0	TG03
20	3/4"	19.05	1.65	25.0	117	18.0	25.0	TG03
25	1"	25.4	1.65	50.5	114	18.0	40.0	TG04
40	1 1/2"	38.1	1.65	50.5	140	28.6	55.0	TG05
BS 4825: Clamp BS 4825-3/pipe BS 4825-1								
8	15	12.7	1.2	25	89	9.6	18.9	TH42
15	20	19.05	1.2	25	102	13.5	25.0	TH43
25	25	25.4	1.65	50.5	114	20.0	39.0	TG04
40	40	38.1	1.65	50.5	140	28.6	55.0	TG05
Clamp 34.0 similar to DIN 32676 series B (ISO pipe)								
15	15	21.3	1.6	34	110	13.5	25.0	TC42

1.) This information is part of the product key (see Product Enquiry Form at the end of this data sheet)

4.10. Plastic body (PV; PD; PP) with spigot connections

Note:

Dimensions in mm, unless otherwise stated

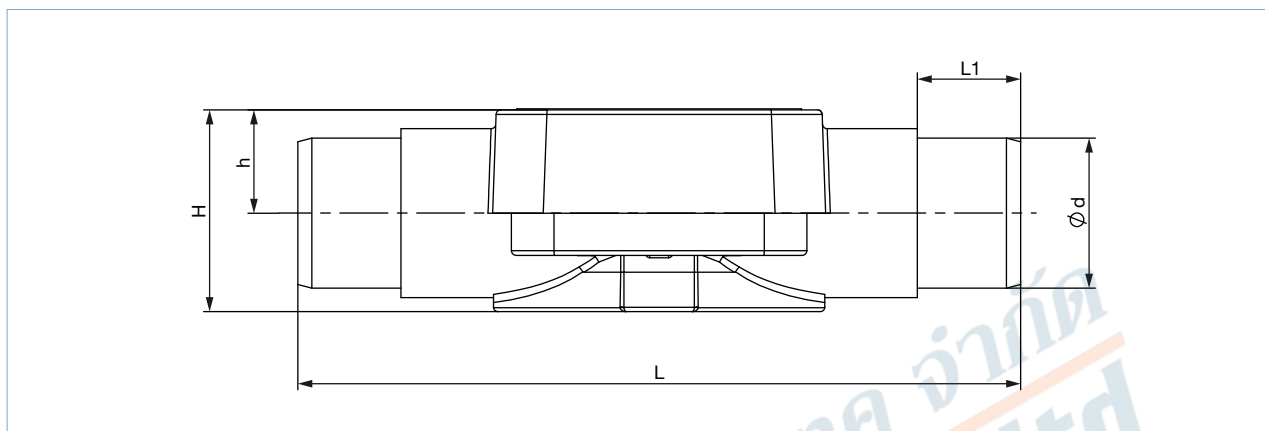

Diaphragm size	Ød	Wall thickness	h	H	L	L1	Product key ^{1.)}
PVC-U (PV)							
15	20	2.5	15	29	124	16	KS25
20	25	2.5	18.5	36	144	19	KS26
25	32	3.5	22	43	154	22	KS27
32	40	4	27	52.5	174	26	KS28
40	50	5	33	65.5	194	31	KS29
PVDF (PD) and PP (PP)							
15	20	2.5	15	29	124	16	SS25
20	25	2.5	18.5	36	144	19	SS26
25	32	3.5	22	43	154	22	SS27
32	40	4	27	52.5	174	26	SS28
40	50	5	33	65.5	194	31	SS29

1.) This information is part of the product key (see Product Enquiry Form at the end of this data sheet)

DTS 1000303711 EN Version: M Status: RL (released | freigegeben | valide) printed: 01.06.2022

4.11. Plastic body (PV, PD, PP) with true union

Note:

Dimensions in mm, unless otherwise stated

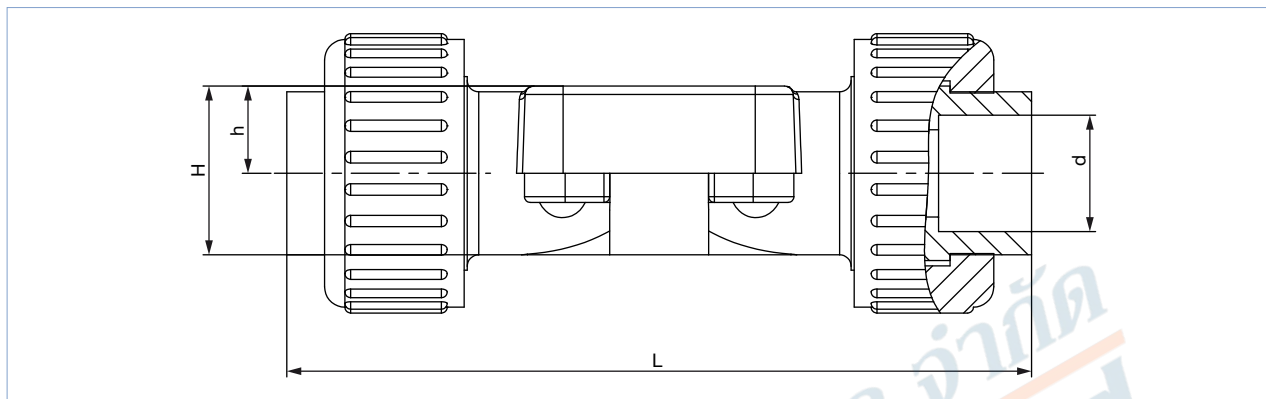

Diaphragm size	L	h	H	Ød	Product key ^{1.)}
PVC-U (PV)					
15	128	15	29	20	KM25
20	152	18.5	36	25	KM26
25	166	22	43	32	KM27
32	192	27	52.5	40	KM28
40	222	33	65.5	50	KM29
PVDF (PD)					
15	129	15	29	20	SM25
20	150	18.5	36	25	SM26
25	162	22	43	32	SM27
32	184	27	52.5	40	SM28
40	210	33	65.5	50	SM29
PP (PP)					
15	125	15	29	20	SM25
20	146	18.5	36	25	SM26
25	158	22	43	32	SM27
32	181	27	52.5	40	SM28
40	207	33	65.5	50	SM29

1.) This information is part of the product key (see Product Enquiry Form at the end of this data sheet)

DTS 1000303711 EN Version: M Status: RL (released | freigegeben | validé) printed: 01.06.2022



4.12. Plastic body (PV, PD, PP) with flange connection

Note:

Dimensions in mm, unless otherwise stated

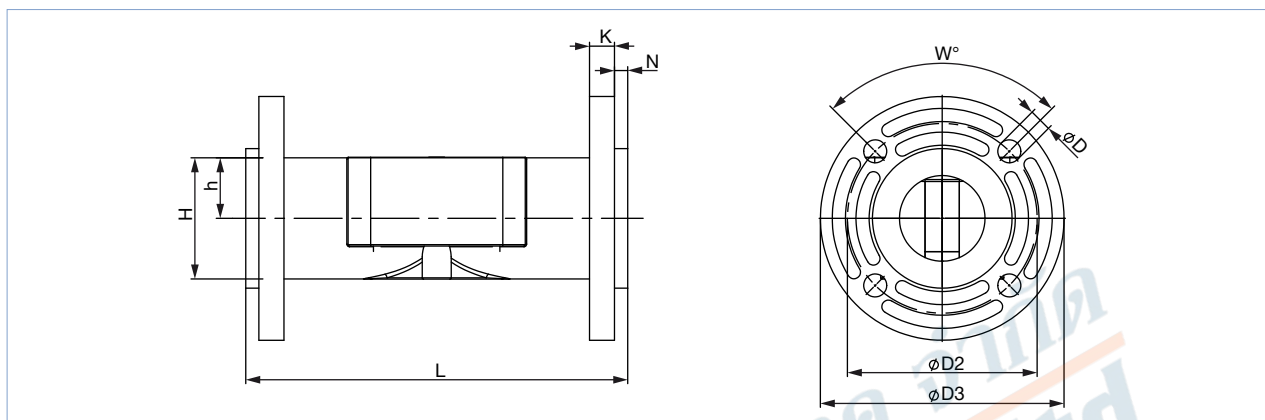

Diaphragm size	L	ØD2	ØD3	K	H	h	ØD	W	N	Product key ^{1.)}
PVC-U (PV), PVDF (PD) and PP (PP)										
15	130	65.5	96	12	–	–	14	4x90°	5.9	FL24
20	150	75	105	14	–	–	14	4x90°	6.9	FL25
25	160	85	115	15	–	–	14	4x90°	6.9	FL26
32	180	100	140	17	–	–	18	4x90°	7.9	FL27
40	200	110	150	17	–	–	18	4x90°	8	FL28

1.) This information is part of the product key (see Product Enquiry Form at the end of this data sheet)

5. Performance specifications

5.1. Fluidic data

Flow characteristics

Note:

- The K_v values may vary slightly with different actuator sizes and diaphragm materials.
- Further K_v values on request
- Flow rate: K_v value water (m³/h) for elastomer diaphragm
- Measurement at +20 °C, 4 bar at valve inlet and 3 bar at valve outlet

Forged body (VS)

Dia-phragm size	Port connection		K _v value [m ³ /h]						
	DN	[mm]	[inch]	DIN EN ISO 1127 ISO 4200 DIN 11866 series B	DIN 11850 series 2 DIN 11866 series A DIN EN 10357 series A	ASME BPE DIN 11866 series C	DIN 11850 series 0	BS4825	SMS3008
				[m ³ /h]	[m ³ /h]	[m ³ /h]	[m ³ /h]	[m ³ /h]	[m ³ /h]
8	6	1/8"	–	–	–	–	1.1	–	–
8	8	1/4"	1.5	–	0.7	1.7	0.5	–	–
8	10	3/8"	1.5	1.5	1.6	–	1.4	–	–
8	15	1/2"	–	–	1.5	–	–	–	–
15	10	3/8"	5.5	3.5	–	–	–	–	–
15	15	1/2"	6.5	6.5	3.1	–	3.7	–	–
15	20	3/4"	–	–	6.5	–	–	–	–
20	20	3/4"	12.5	12.4	8.4	–	8.9	–	–
25	25	1"	18	20	15.5	–	15.5	16	–
40	32	1 1/4"	–	34	–	–	–	–	–
40	40	1 1/2"	41	40	37	–	37	38	–

Tube valve body (VP)

Diaphragm size DN	Port connection		K _v value [m ³ /h]		
	[mm]	[inch]	DIN EN ISO 1127 ISO 4200 DIN 11866 series B [m ³ /h]	DIN 11850 series 2 DIN 11866 series A DIN EN 10357 series A [m ³ /h]	ASME BPE DIN 11866 series C [m ³ /h]
8	8	¼"	1.9	–	–
8	10	⅜"	–	1.9	–
8	15	½"	–	–	1.8
15	10	⅜"	–	–	7.1
15	15	½"	7.2	7.4	–
15	20	¾"	–	7.4	–
20	20	¾"	13.5	–	–
20	25	1"	–	14.9	12.8
25	32	1¼"	–	22.3	–
25	25	1"	20.8	–	–
32	40	1½"	–	34.8	31
40	40	1½"	47.9	–	–
40	50	2"	–	46.2	43

Cast body (VG)

Diaphragm size DN	Port connection		K _v value [m ³ /h]
	[mm]	[inch]	
8	8	¼"	1
15	15	½"	5.6
20	20	¾"	10.7
25	25	1"	14.6
40	40	1½"	35

Plastic body (PV; PD; PP)

Diaphragm size DN	Port connection		K _v value [m ³ /h]
	[mm]	[inch]	
15	15	½"	3
20	20	¾"	7
25	25	1"	11.4
32	32	1¼"	17
40	40	1½"	24.5

5.2. Operating limits

Medium pressure

Diaphragm size DN	Max. operating pressure for seal material	
	EPDM, FKM [bar]	PTFE/EPDM, advanced PTFE/EPDM, GYLON®/EPDM laminated [bar]
8	10	10
15	10	10
20	10	10
25	10	10
32	8	5.5
40	4	2.5

Operating limits for ambient and medium temperature

The maximum permissible temperature for the environment and the medium are dependent on each other. The maximum allowable temperature curves of different device variants can be seen in the temperature chart.

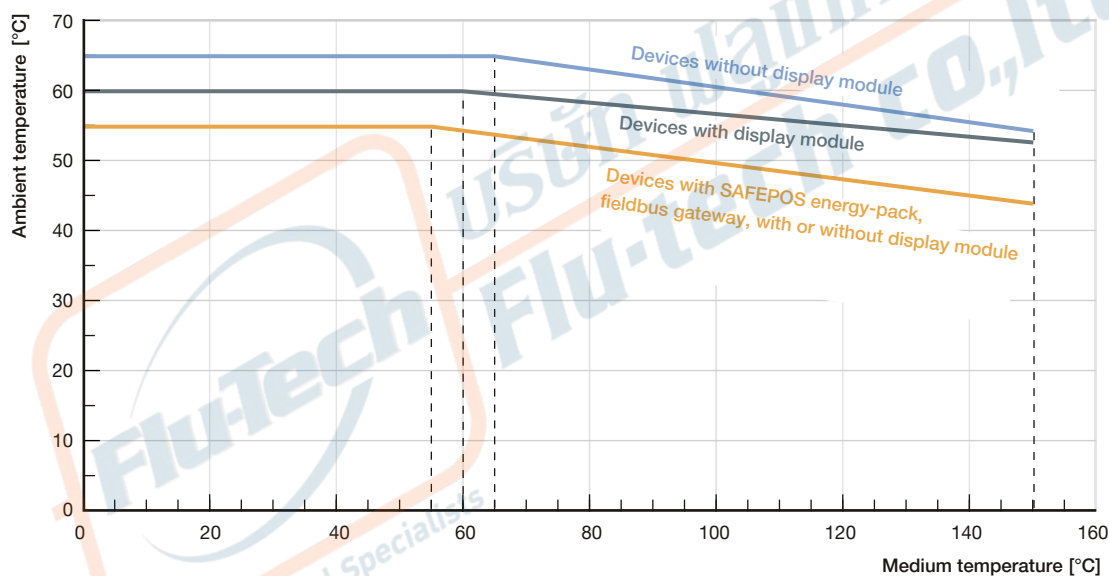

DTS 1000303711 EN Version: M Status: RL (released | freigegeben | validé) printed: 01.06.2022

5.3. Electrical control and interfaces

Interface diagram

The position of the actuator is regulated according to the set-point position value. The set-point position value is specified either by an external standard signal (analogue) or via a field bus (digital).

Analogue control

For analogue control 2 variants are available for the inputs and outputs and the connection interface

Inputs and outputs:

- 1 analogue input, 1 binary input
- 1 analogue input, 1 binary input, 1 analogue output, 2 binary output (option)
- 1 input for actual process value (for process controller version)

Interface:

- Cable gland with connection terminal
- M12 circular plug-in connectors (optional)

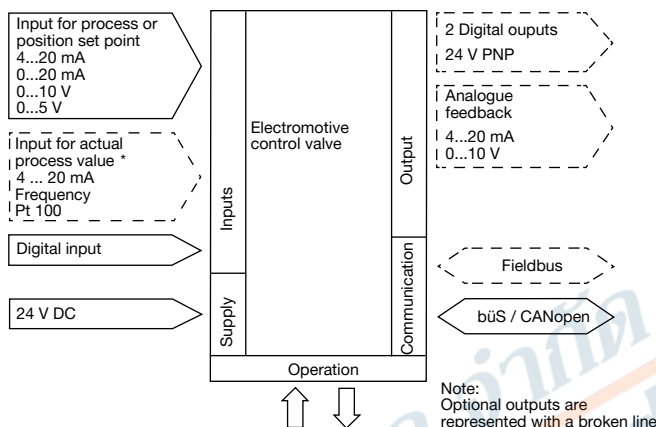

Control data	
Input setpoint analogue	Galvanically isolated from the supply voltage and analogue output 0/4...20 mA (input resistance 70 Ω) 0...5/10 V (input resistance 22 kΩ)
Output analogue	Max. current 10 mA (for voltage output 0...5/10 V) Load 0...800 Ω (for current output 0/4...20 mA)
Input digital	0...5 V = log "0", 10...30 V = log "1" inverted input reversed accordingly
Output digital	PNP, Current limitation 100 mA
Input actual value analogue (optional)	
4...20 mA	Input resistance: 80 Ω Resolution: 12 bit
Frequency	Measuring range: up to 1000 Hz Input resistance: >30 kΩ Resolution: 0.1 % of measurement value Input signal: >300 mVss Signal form: sine, rectangle, triangle
Pt 100	Measuring range: -20 °C...+220 °C Resolution: 0.01 °C Measurement current: 1 mA
Communication	
Communication interface (bUS)	Connection to PC via USB bUS interface set
Communication software (bUS)	Bürkert Communicator, see Type 8920 ▶

DTS 1000303711 EN Version: M Status: RL (released | freigegeben | valide) printed: 01.06.2022

6. Product design and assembly

6.1. Product features

Note

More detailed information can be found in the **operating instructions** ►.

<p>Operation</p>	
<p>Devices without display module: The basic functions are operated by 4 DIP switches and 2 push buttons. These are located under the blind cover which can be removed manually by turning. Through the būs service access, the device can also be configured in detail with the Bürkert Communicator software. For this, the optional USB-būs interface kit is required.</p>	<p style="text-align: right;">Blind cover dismantled</p>
<p>Rugged Touch Display (optional): The robust display module is easy to use, it configures and displays all the required functions. In addition to the start screen you can also switch to the configuration view and user-specified views as needed. All functions of the device without display module like būs service interface are available, too.</p>	
<p>Mechanical manual override: The manual override for mechanical movement of the valve is located under the blind cover or display module and ensures that the actuator can be operated even if the power supply fails.</p> <p>Electrical manual override: The electrical manual override for operation can be carried out directly on the touch display or, in the version without display, via two buttons under the blind cover.</p>	
<p>Display elements</p>	
<p>Display 360° LED light ring: A clearly visible 360° LED ring is attached to the blind cover or display module to indicate the device status, the valve end position and the operating status. The LED light ring lights up, blinks or flashes into one or changing colours, depending on the LED mode set.</p>	
<p>Mechanical position indicator: The mechanical position indicator shows the current valve position even if the supply voltage fails.</p>	
<p>Data transmission (optional)</p>	
<p>SIM card (optional): With the optionally available SIM card, device-specific values and user settings can be stored and quickly transferred to another device.</p>	<p style="text-align: right;">SIM card holder</p>

DTS 1000303711 EN Version: M Status: RL (released | freigegeben | validé) printed: 01.06.2022

Operation

büS service interface:

The büS service interface connects the device with the Communicator software on a PC, laptop or smartphone. From there a configuration of the device or an error diagnosis can be carried out.

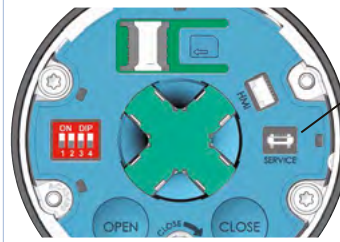

büS service interface
Connection for CAN adapter or
USB-büS interface set

Safety position via energy storage (optional)

The safety starting positions in case of power interruption is realized with the optional energy storage SAFEPOS energy-pack. The desired position is set via the menu. In addition to the end positions (open/closed), any desired intermediate position can be defined here. The energy storage has a lifespan of up to 10 years, depending on the operating conditions. The power of the energy storage is monitored and a warning is displayed to indicate its life is coming to an end. The storage device is designed as a plug-in module to facilitate replacement. Without energy storage, the valve remains in the last position it was in. The energy storage device is fully charged and ready for operation after a maximum of 100 seconds (depending on the operating conditions). The energy storage device cannot be retrofitted in the field.

SAFEPOS
energy-pack



Fieldbus: EtherNet/IP, PROFINET, Modbus TCP (optional)

The fieldbus gateway for EtherNet/IP, PROFINET and Modbus TCP is integrated in an additional module. It has 2 fieldbus connections with 4 pin M12 circular sockets. The interfaces for the fieldbus connection and the status LEDs are located under the gateway housing cover. If there is a need for it to be include in a network then the configuration of the Ethernet can be performed via the web server. The gateway cannot be retrofitted in the field.

Display module

Fieldbus gateway



Fieldbus connection M12
(2 port Ethernet switch)

DTS 1000303711 EN Version: M Status: RL (released | freigegeben | validé) printed: 01.06.2022

6.2. Product assembly

The electromotive linear actuator consists of a brushless direct current motor, gears and a threaded spindle. The valve spindle, which is connected to the threaded spindle, transfers the force to the diaphragm. The electronic control system is actuated either via standard signals (analogue) or via a field bus (digital). Available controller types are a position controller or a process controller. Optionally there is the energy pack (SAFEPOS energy-pack) for the device. If the supply voltage fails, the energy pack supplies the actuator with the required energy to move the valve into the required position which can be adjusted via a menu.

The valve position can be manually changed in 2 ways. Either over an electrical manual control or over mechanical manual control, if no supply voltage applied. The device can be set and operated either via 2 capacitive buttons and 4 DIP switches or optionally on a display with touch-screen. There is also the option of setting the device via the bus service interface and by using the PC software "Bürkert Communicator".

The intelligent process valve Type 3363 offers options for process monitoring, valve diagnostics and predictive maintenance. The state of the device is monitored and if necessary warnings or error messages for inadmissible environmental and operational conditions, disfunctional components or a critical state of the energy storage are displayed.

For a good diaphragm service life the actuator force is adjusted according to diaphragm size by default. It can even be adapted according to the operational conditions for an optimum diaphragm cycle life.

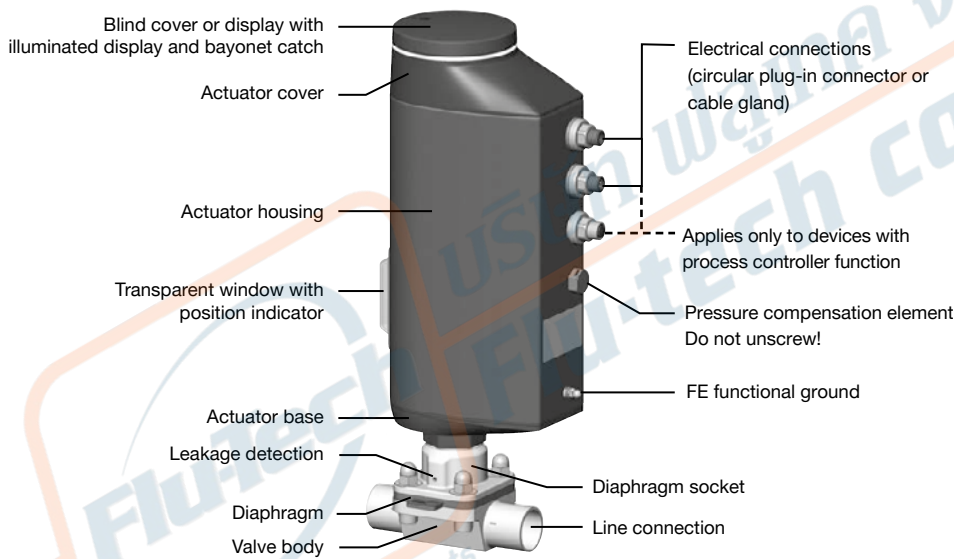

Integrated position controller

The position of the actuator (stroke) is controlled according to the position set-point. The position set-point is either given by an external standard signal (analogue) or via a fieldbus (digital). The displacement transducer records the actual position (POS) of the electric linear actuator. This actual position value is compared by the positioner with the position set-point (CMD) specified as standard signal. If there is a system deviation (Xd1), the electric motor drive is controlled via the manipulated variable CTRL and the actual position value is changed accordingly.

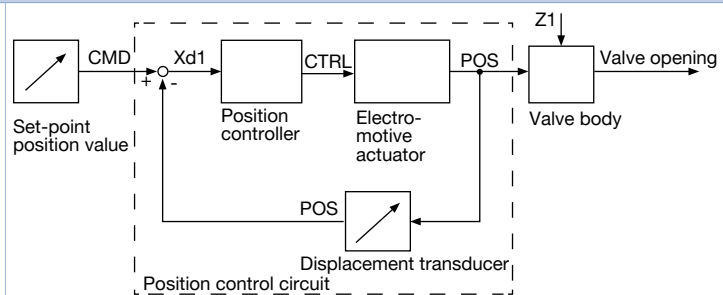

Integrated process controller (optional)

The additionally implemented PID controller allows process control. The set-point position of the valve is calculated from the external signal (e.g. level, pressure, flow rate, temperature) for the process set-point and the actual process value via the control parameters (PID controller).

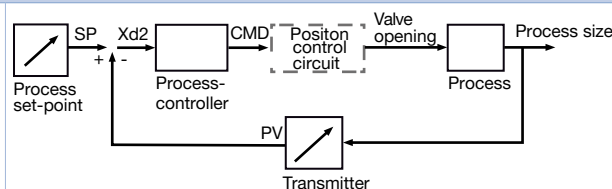

DTS 1000303711 EN Version: M Status: RL (released | freigegeben | validé) printed: 01.06.2022

7. Ordering information

7.1. Bürkert eShop – Easy ordering and quick delivery



Bürkert eShop – Easy ordering and fast delivery

You want to find your desired Bürkert product or spare part quickly and order directly? Our online shop is available for you 24/7. Sign up and enjoy all the benefits.

[Order online now](#)

7.2. Bürkert product filter



Bürkert product filter – Get quickly to the right product

You want to select products comfortably based on your technical requirements? Use the Bürkert product filter and find suitable articles for your application quickly and easily.

[Try out our product filter](#)

7.3. Ordering chart accessories

Standard accessories

Description	Article no.
SIM card for data transmission between devices	291773 ☒
Holding device for port connection DN08...40 ^{1.)}	697473 ☒
Plastic blind cover	277881 ☒
Energy storage SAFEPOS energy-pack	285834 ☒

1.) For diaphragm size 08, the holding device is included in the delivery.

Accessories cable

Note:

For connection to a bus/CANopen network see [cabling guide](#) ▶.

Description	Article no.
Connection cable with M12 socket, 4 pin, (length 5 m) for operating voltage (without communication)	918038 ☒
Connection cable with M12 socket, 8 pin, (length 2 m) for input and output signals	919061 ☒
Connection cable with M12 plug, 5 pin, (length 2 m) for process actual value input signals (only for version with process controller)	559177 ☒

Bürkert accessories**Note:**

- For connection to a bus/CANopen network see **cabling guide** ▶.
- Detailed accessory tables can be found in the cabling guide

Description	Article no.
Software Bürkert Communicator, Type 8920	LINK ▶
büS stick set 1 (including power supply unit, bus-stick, terminating resistor, Y-distributor, 0.7 m cable with M12 connector)	772426 ☒
büS stick set 2 (including bus-stick, terminating resistor, Y-distributor, 0.7 m cable with M12 connector)	772551 ☒
büS adapter for büS interface set (M12 on büS service interface Micro-USB)	773254 ☒

7.4. Bürkert product enquiry form

Bürkert product enquiry form: Would you like to make a specific product enquiry based on your technical requirements? Please use our product enquiry form **at the end of this data sheet**. There you will find all the information relevant to your Bürkert contact person that will help us to process your enquiry in the best possible way.

Bürkert specification key: In our product enquiry form you will find a complete explanation of the composition of our specification key. You will find our product enquiry form **at the end of this data sheet**.



Specification key - Examples



Key Feature	Type	Control function	Nominal diameter diaphragm	Diaphragm material	Body material	Port connection	Port connection	Actuator version	Actuator size	Pilot air port	Actuator	Variable	Variable	Variable
Key No. →	1	2	3	4	5	6	6	7	8	9	10	V1	V2	V3

2 way diaphragm valve														
Type 2030 CLASSIC	2030	A	20.0	AD	PV	KM26	-	C	E	-	-			
Type 2031 CLASSIC	2031	A	20.0	AD	VS	SA93	-	C	E	-	-	NK52	NO14	
Type 2063 INOX	2063	A	20.0	AD	VS	SA93	-	H	M	-	-	NK52	NO14	
Type 2103 ELEMENT	2103	A	20.0	AD	PV	KM26	-	G	M	FA01	-			
Type 2103 ELEMENT	2103	A	20.0	AD	VS	SA93	-	G	M	FA01	-	NK52	NO14	
Type 3232	3232	-	20.0	AD	PV	KM26	-	-	-	-	D050			
Type 3233	3233	-	20.0	AD	VS	SA93	-	-	-	-	D051	NK52	NO14	
T-diaphragm valve														
Type 2032 CLASSIC	2032	A	20.0	AD	VH	SODH	SA93	D	E	-	-	NK52	NO14	
Type 2064 INOX	2064	A	20.0	AD	VH	SODH	SA93	-	M	-	-	NK52	NO14	
Type 2104 ELEMENT	2104	A	20.0	AD	VH	SODH	SA93	-	M	FA01	-	NK52	NO14	
Type 3234	3234	-	20.0	AD	VH	SODH	SA93	-	-	-	D050	NK52	NO14	
Tank bottom diaphragm valve														
Type 2033 CLASSIC	2033	A	20.0	AD	VH	SA93	-	D	F	-	-	NK52	NO14	
Type 2065 INOX	2065	A	20.0	AD	VH	SA93	-	-	M	-	-	NK52	NO14	
Type 2105 ELEMENT	2105	A	20.0	AD	VH	SA93	-	-	M	FA01	-	NK52	NO14	
Type 3235	3235	-	20.0	AD	VH	SA93	-	-	-	-	D050	NK52	NO14	

1.) NK52, NOxx only for stainless steel bodies

Product Enquiry Form
Diaphragm valve with straight
way valve, T-valve or tank bottom
valve



Key Legend

Note:

- Other versions on request
- Available Type sizes see corresponding data sheet

Key no. 2: Control function (SF)		Key no. 8: Actuator size (ANTG)	
A	Closed with spring force	B	ø 32
B	Open with spring force	C	ø 40
I	Without pressure spring	D	ø 50
Key no. 3: Nominal diameter diaphragm (DN)		E	ø 63
8	25	F	ø 80
15	32	G	ø 100
20	40	H	ø 125
Key no. 4: Diaphragm material (DWST)		K	ø 175
AD	EPDM	L	ø 225
EA	PTFE/EPDM	M	ø 70
EU	Advanced PTFE/EPDM laminated	N	ø 90
ER	Gylon®/EPDM laminated	P	ø 130
Key no. 5: Body material (WKST)		Key no. 9: Pilot air port (ELEMENT) (STLA)	
PD	PVDF (Polyvinylidene fluoride)	FA01	Pilot air port Push-In 6/4, 1/4"
PP	PP (Polypropylene)	FA02	Pilot air port G1/8
PV	PVC-U (Polyvinyl chloride)	FA03	Interface ELEMENT control
VG	Stainless steel precision casting 1.4435/316L	Key no. 10: Actuator (ANTR)	
VH	Stainless steel block material 1.4435/316L	D050	Handwheel and attachment PPS
VI	Stainless steel block material 1.4435 BN2/316L ASME BPE	D051 ^{1.)}	Handwheel PPS and attachment St. St.
VP	Stainless steel tube 1.4435 BN2/316L	D052 ^{2.)}	Handwheel and attachment St. St.
VS	Stainless steel-forged 1.4435 BN2/316L ASME BPE	1.) Alternatively D058	
Key no. 6: Port connection (LTA1, LTA2)		2.) Alternatively D059 or D102	
Listed in detail below		Key no. V1, V2, ...: Variable code (VAR1, VAR2, VAR3)	
Key no. 7: Actuator version (ANTA)		NK52 ^{3.)}	Acceptance test certificate 3.1 according to EN 10204
C	PA actuator (only CLASSIC)	NO14 ^{3.)}	Mechanically polished Ra ≤ 0.5 µm (ASME BPE SF1)
D	PPS actuator (only CLASSIC)	NO17 ^{3.)}	Electropolished Ra ≤ 0.38 µm (ASME BPE SF4 / DIN HE4)
G	ELEMENT design actuator (only ELEMENT)	NO06 ^{3.)}	Mechanically polished Ra ≤ 0.76 µm (ASME BPE SF3 / DIN H2)
H	St. St. actuator (only INOX)	NO16 ^{3.)}	Electropolished Ra ≤ 0.6 µm (ASME BPE SF6)
		EC04	Reduced spring force
		3.) NK52, NOxx only for stainless steel bodies	

Key no. 6: Port connection (LTA)

Weld connection								
DN [mm]	EN ISO 1127 / ISO 4200 DIN 11866 R. B	SMS 3008	DIN 11850 R. 0	DIN 11850 R. 1	DIN 11850 R. 2 DIN 11866 R. A	DIN 11850 R. 3	BS4825	ASME BPE DIN 11866 R. C
4	-	-	SC40-6.0x1.0	-	-	-	-	-
6	SA78-10.2x1.6	-	SC41-8.0x1.0	-	-	-	-	SA89-3.17x0.56
8	SA40-13.5x1.6	-	SC42-10.0x1.0	-	-	-	SODB-6.35x1.2	SA90-6.35x0.89
10	SA41-17.2x1.6	-	-	SF40-12.0x1.0	SD40-13.0x1.5	SE40-14.0x2.0	SODC-9.53x1.2	SA91-9.53x0.89
15	SA42-21.3x1.6	SA58-12.0x1.0	SC43-18.0x1.5	SF41-18.0x1.0	SD42-19.0x1.5	SE42-20.0x2.0	SODD-12.7x1.2	SA92-12.7x1.65
20	SA43-26.9x1.6	SA59-18.0x1.0	SC44-22.0x1.5	SF42-22.0x1.0	SD43-23.0x1.5	SE43-24.0x2.0	SODE-19.05x1.2	SA93-19.05x1.65
25	SA44-33.7x2.0	SA60-25.0x1.2	SC45-28.0x1.5	SF43-28.0x1.0	SD44-29.0x1.5	SE44-30.0x2.0	-	SODF-25.4x1.65
32	SA45-42.4x2.0	SA61-33.7x1.2	SC46-34.0x1.5	SF44-34.0x1.0	SD45-35.0x1.5	SE45-36.0x2.0	-	-
40	SA46-48.3x2.0	SA62-38.0x1.2	SC47-40.0x1.5	SF45-40.0x1.0	SD46-41.0x1.5	SE46-42.0x2.0	-	SODH-38.1x1.65
50	SA47-60.3x2.0	SA63-51.0x1.2	SC48-52.0x1.5	SF46-52.0x1.0	SD47-53.0x1.5	SE47-54.0x2.0	-	SODI-50.8x1.65
65	SA48-76.1x2.0	SA64-63.5x1.6	-	-	SD48-70.0x2.0	-	-	SODJ-63.5x1.65
80	SA49-88.9x2.3	SA65-76.1x1.6	-	-	SD49-85.0x2.0	-	-	SODK-76.2x1.65
100	SA39-114.3x2.3	SA66-101.6x2.0	-	-	SD50-104.0x2.0	-	-	SODL-101.6x2.11

DTS 1000303711 EN Version: M Status: RL (released | freigegeben | valide) printed: 01.06.2022



บริษัท ฟลูเทค จำกัด
FLU-TECH CO.,LTD

845/3-4 หมู่ 3 ถ.เทพารักษ์ ต.เทพารักษ์ อ.เมือง จ.สมุทรปราการ 10270
 845/3-4 Thepharak RD., T.Thepharak, A.Muang, Samutprakarn 10270 THAILAND
 Tel. 0 2384 6060, Fax 0 2384 5701, Email : sales@flutech.co.th, www.flutech.co.th

Product Enquiry Form
Diaphragm valve with straight
way valve, T-valve or tank bottom
valve

bürkert

Clamp connection					
DN [mm]	Clamp 34,0 similar to DIN 32676 R. B (ISO tube (ISO4200))	DIN 32676 R. A (DIN tube (DIN11850))	DIN 32676 R. B (ISO tube (ISO4200))	ASME BPE	BS 4825 (Clamp BS 4825-3, tube BS 4825-1)
8	TC51-13.5x1.6 Cl: 34.0	TD40-10.0x1.0 Cl: 25.0	TC40-13.5x1.6 Cl: 25.0	TG 50-6.35x0.89 Cl: 25.0	-
10	TC41-17.2x1.6 Cl: 34.0	TD41-13.0x1.5 Cl: 34.0	TC53-17.2x1.6 Cl: 25.0	TG 01-9.53x0.89 Cl: 25.0	-
15	TC42-21.3x1.6 Cl: 34.0	TD42-19.,0x1.5 Cl: 34.0	TC52-21.3x1.6 Cl: 50.5	TG 02-12.7x1.65 Cl: 25.0	TH42-12.7x1.2 Cl: 25.0
20	-	TD43-23.0x1.5 Cl: 34.0	TC43-26.9x1.6 Cl: 50.5	TG 03-19.05x1.65 Cl: 25.0	TH43-19.05x1.2 Cl: 25.0
25	-	TD44-29.0x1.5 Cl: 50.5	TC44-33.7x2.0 Cl: 50.5	TG 04-25.4x1.65 Cl: 50.5	-
32	-	-	-	-	-
40	-	TD46-41.0x1.5 Cl: 50.5	TC46-48.3x2.0 Cl: 64.0	TG 05-38.1x1.65 Cl: 50.5	-
50	-	TD47-53.0x1.5 Cl: 64.0	TC47-60.3x2.0 Cl: 77.5	TG 06-50.8x1.65 Cl: 64.0	-
65	-	-	TC48-76.1x2.0 Cl: 91.0	TG 07-63.5x1.65 Cl: 77.5	-
80	-	-	TC49-88.9x2.3 Cl: 106.0	TG 08-76.2x,65 Cl: 91.0	-
100	-	-	TC50-114.3x2.3 Cl: 130.0	TG 09-101.6x2.11 Cl: 119.0	-

Plastic connection					
DN [mm]	Welded connection socket (only WKST=PD, PP)	Welded connection threaded socket (only WKST=PD, PP)	Adhesive bond socket (only WKST=PV)	Adhesive bond threaded socket (only WKST=PV)	Loose-type flange (up to DN65) Fixed flange (from DN80)
15	SS25 - ø20	SM25 - ø20	KS25 - ø20	KM25 - ø20	FL24
20	SS26 - ø25	SM26 - ø25	KS26 - ø25	KM26 - ø25	FL25
25	SS27 - ø32	SM27 - ø32	KS27 - ø32	KM27 - ø32	FL26
32	SS28 - ø40	SM28 - ø40	KS28 - ø40	KM28 - ø40	FL27
40	SS29 - ø50	SM29 - ø50	KS29 - ø50	KM29 - ø50	FL28
50	SS30 - ø63	SM30 - ø63	KS30 - ø63	KM30 - ø63	FL29
65	-	-	-	-	FL30
80	-	-	-	-	FF31
100	-	-	-	-	FF32

DTS 1000303711 EN Version: M Status: RL (released | freigegeben | validé) printed: 01.06.2022



บริษัท ฟลูเทค จำกัด
FLU-TECH CO.,LTD

845/3-4 หมู่ 3 ถ.เทพารักษ์ ต.เทพารักษ์ อ.เมือง จ.สมุทรปราการ 10270
 845/3-4 Thepharak RD., T.Thepharak, A.Muang, Samutprakarn 10270 THAILAND
 Tel. 0 2384 6060, Fax 0 2384 5701, Email : sales@flutech.co.th, www.flutech.co.th