



Full bore magmeter without flanges (wafer version)

- Combination of sensor S054 and transmitter SE56
- Continuous measurement or Batch Control
- For water treatment and general purpose applications
- Flow rate measurement for DN 25...DN 200

Product variants described in the data sheet may differ from the product presentation and description.

Can be combined with



Type 8644 ▶
Remote Process Actuation Control System AirLINE



Type 8693 ▶
Digital electro-pneumatic process controller for the integrated mounting on process control valves

Type description

The complete full bore magflowmeter Type 8054, which consists of a magnetic sensor Type S054 (in compact or remote version) connected to a transmitter Type SE56 (without display in compact version or with display in compact or remote version), is designed for applications with liquids with a minimum conductivity of 5 μ S/cm.

Combined with a valve as the actuating element, the complete full bore magflowmeter Type 8054 can also control high-precision dosing operations and flow measurements in potable water treatment and waste water treatment.

Table of contents

1. General Technical Data	3
<hr/>	
2. Product versions	5
Compact version.....	5
Remote version.....	5
<hr/>	
3. Dimensions	6
3.1. Wafer compact version.....	6
3.2. Wafer remote version with junction box	6
<hr/>	
4. Product installation	7
4.1. Installation notes.....	7
4.2. Selection of the nominal diameter	8
<hr/>	
5. Product operation	8
5.1. Measuring principle	8
<hr/>	
6. Ordering information	9
6.1. Bürkert eShop – Easy ordering and quick delivery.....	9
6.2. Recommendation regarding product selection	9
6.3. Bürkert product filter.....	9
6.4. Ordering chart sensor Type S054	9
6.5. Ordering chart accessories.....	10

1. General Technical Data

The 8054 flowmeter is available with different transmitters.
The versions of the transmitter, Type SE56, are:

Standard compact version with display	Standard remote version with display	Basic compact version with or without display	Compact version without display

Detailed information can be found in the data sheet of the transmitter for electromagnetic-inductive flow sensors, see **data sheet Type SE56** ▶.

Product properties

Material

Non wetted parts

Sensor housing Carbon steel painted (stainless steel 304 or 316 on request)

Wetted parts

Electrode Stainless steel 316L (Alloy C, Titanium, Tantalum, Platinum-rhodium on request)

Lining PP or ebonite (hard rubber) (PTFE on request)

Seal

- FKM (EPDM on request) with PP lining
- Without gasket with ebonite (hard rubber) lining (with PTFE lining on request)

Dimensions Detailed information can be found in chapter **"3. Dimensions"** on page 6.

Pipe diameter DN 25...DN 200 (upper DN on request)

Measuring principle Electromagnetic induction

Detailed information can be found in chapter **"5.1. Measuring principle"** on page 8.

Measuring range 0...0.72 m³/h to 0...1130 m³/h
Detailed information can be found in chapter **"6.4. Ordering chart sensor Type S054"** on page 9.

Performance data

Under reference conditions: water temperature = 20 °C, ambient temperature = 25 °C, constant flow rate during the test, liquid speed > 1 m/s

Measurement deviation If used with SE56 transmitter

- In standard compact version: ±0.2% of reading
- In standard remote version: ±0.2% of reading
- In Basic compact version: ±0.8% of reading
- In compact version without display: ±0.2% of reading

Repeatability If used with SE56 transmitter

- In standard compact version: ±0.1%
- In standard remote version: ±0.1%
- In Basic compact version: ±0.2%
- In compact version without display: ±0.1%

Vacuum resistance 200 mbar (2.9 PSI) absolute at 100 °C (212 °F)

Medium data

Fluid temperature

- With PP lining used with SE56 transmitter:
 - in standard compact version: -0...+60 °C (+32...+140 °F)
 - in standard remote version: -0...+60 °C (+32...+140 °F)
 - in Basic compact version: -0...+60 °C (+32...+140 °F)
 - in compact version without display: -0...+60 °C (+32...+140 °F)
- With PTFE lining (on request) used with SE56 transmitter:
 - in standard compact version: -20...+100 °C (-4...+212 °F)
 - in standard remote version: -20...+130 °C (-4...+266 °F)
 - in Basic compact version: -10...+100 °C (+14...+212 °F)
 - in compact version without display: -20...+100 °C (-4...+212 °F)

Fluid pressure	PN 16 (232 PSI) with PP lining
Minimum conductivity	5 µS/cm (or 20 µS/cm with demineralised water)

Process/Port connection & communication

Process connection	Wafer
Electrical connection	2 cable glands PG9 (for remote version of the sensor)

Approvals and certificates

Standards

Degree of protection according to IEC/EN 60529	<p>If use with SE56 transmitter:</p> <ul style="list-style-type: none"> • in standard compact version: IP65 and IP67 • in standard remote version: <ul style="list-style-type: none"> – IP65 – IP68 (if the junction box of the sensor is filled with resin) • in Basic compact version: IP65 • in compact version without display: IP65 and IP67
--	--

Directives

CE directives	The applied standards, which verify conformity with the EU Directives, can be found on the EU Type Examination Certificate and/or the EU Declaration of conformity (if applicable).
Pressure equipment directives	<p>The device is subject to the requirements of the Pressure Equipment Directive 2014/68/EU. Category II device for group 1 and 2 fluids under the following conditions:</p> <ul style="list-style-type: none"> • maximum allowable pressure (PS) ≤ 40 bar • minimum/maximum temperature (TS): -10/+130 °C • within the following limits for liquids of group 2: <ul style="list-style-type: none"> – PN 10 for DN 400...DN 500 – PN 16 for DN 250...DN 300 – PN 25 for DN 200...DN 250 – PN 40 for DN 40...DN 250 • within the following limits for liquids of group 1 with a vapour pressure at the maximum allowable temperature not exceeding 0.5 bar (g): for diameters above DN 25 and PS × DN > 2000

Environment and installation

Ambient temperature	<p>If used with SE56 transmitter:</p> <ul style="list-style-type: none"> • in standard compact version: -20...+60 °C (-4...+140 °F) (operation and storage) • in standard remote version: -20...+60 °C (-4...+140 °F) (operation and storage) • in Basic compact version: <ul style="list-style-type: none"> – -10...+50 °C (+14...+122 °F) (operating) – -20...+50 °C (-4...+122 °F) (storage) • in compact version without display: -20...+40 °C (-4...+104 °F) (operation and storage)
Relative air humidity	≤ 90 %, without condensation
Height above sea level	Max. 2000 m
Operating conditions	Continuous
Equipment mobility	Fixed device
Application range	Indoor and outdoor (protect the device against electromagnetic interference, ultraviolet rays and against the effects of climatic conditions)
Installation category	Category II according to UL/EN 61010-1
Pollution degree	Degree 2 according to UL/EN 61010-1

2. Product versions

The flowmeter Type 8054 is available in a compact or remote version.

Compact version



A compact version of the flowmeter is made of a sensor Type S054 in a compact version and a compact transmitter Type SE56.

The compact flowmeter is also available in 3 versions depending on the used transmitter.

Product details	
Standard transmitter	With display, housing in aluminium or stainless steel
Basic transmitter	With or without display, housing in nylon
Without display transmitter	Without display, housing in stainless steel



Two different components must be ordered in order to select a complete device. The following information is required:

- **Article no.** of the compact sensor Type S054 (Detailed information can be found in chapter "6.4. Ordering chart sensor Type S054" on page 9)
- **Article no.** of the compact transmitter Type SE56 (see [data sheet Type SE56](#) ▶)

Remote version



A remote version of the flowmeter is made of a sensor Type S054 in a remote version and a remote transmitter Type SE56.

The remote flowmeter is available with the following transmitter.

Product details	
Standard transmitter	With display, housing in aluminium or stainless steel



Two different components must be ordered in order to select a complete device. The following information is required:

- **Article no.** of the remote sensor Type S054 (Detailed information can be found in chapter "6.4. Ordering chart sensor Type S054" on page 9)
- **Article no.** of the remote transmitter Type SE56 (see [data sheet Type SE56](#) ▶)

3. Dimensions

3.1. Wafer compact version

Note:

- Detailed information on the dimensions of the SE56 transmitter can be found in **data sheet Type SE56** ▶.
- Dimensions in mm (unless specified differently)

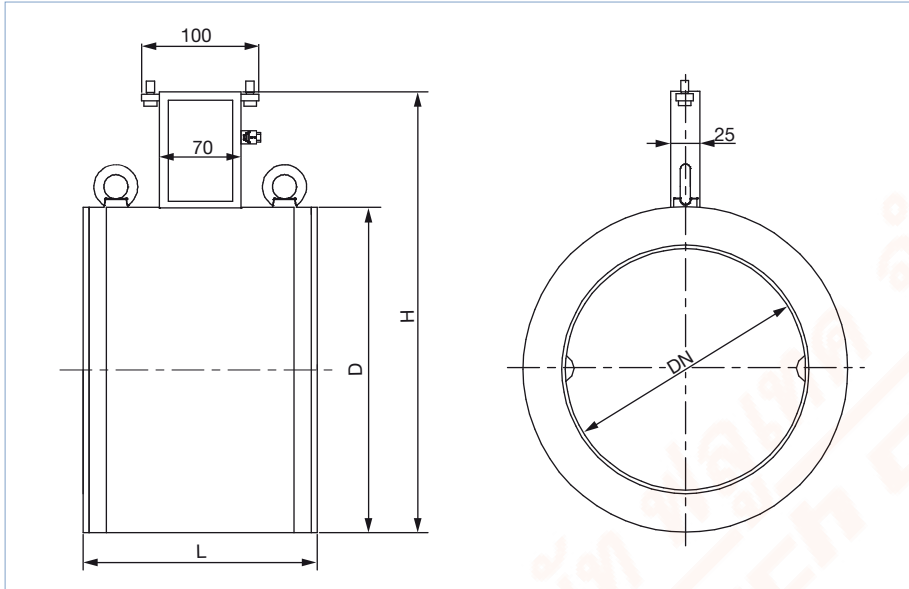

DN	L ^{1.)}	H	D
25	100	147	56
32	100	153	62
40	100	161	70
50	100	177	86
65	150	199	108
80	150	209	118
100	150	235	144
125	180	263	172
150	180	291	200
200	200	362	271

1.) tolerance +0/-3 mm

3.2. Wafer remote version with junction box

Note:

- Detailed information on the dimensions of the SE56 transmitter can be found in **data sheet Type SE56** ▶.
- Dimensions in mm (unless specified differently)

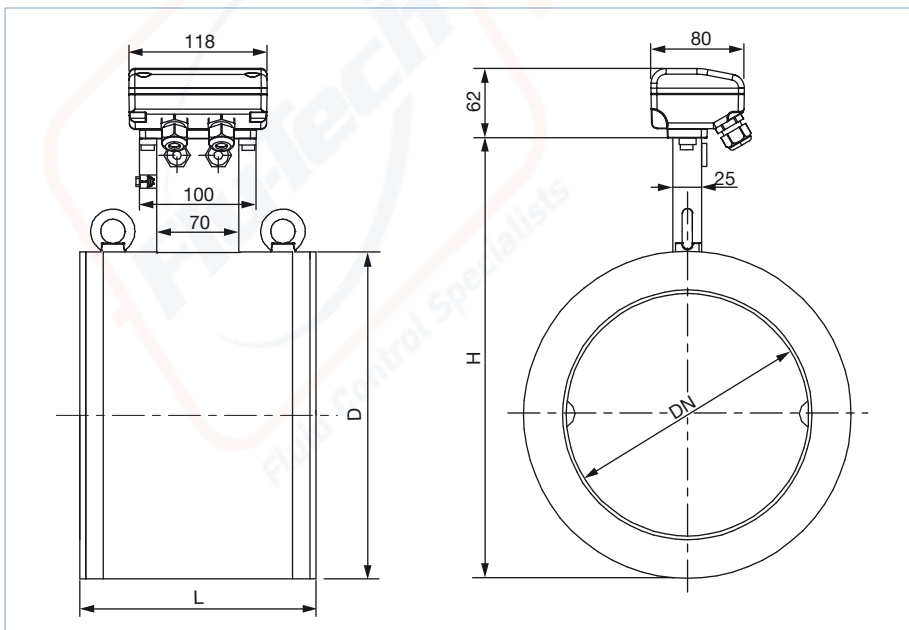

DN	L ^{1.)}	H	D
25	100	147	56
32	100	153	62
40	100	161	70
50	100	177	86
65	150	199	108
80	150	209	118
100	150	235	144
125	180	263	172
150	180	291	200
200	200	362	271

1.) tolerance +0/-3 mm

DTS 1000425130 EN Version: - Status: RL (released | freigegeben | validé) printed: 27.05.2020

4. Product installation

4.1. Installation notes

Note:

The flow meter is not designed for gas and steam flow measurement.

- During flowmeter operation the pipe must be completely full.

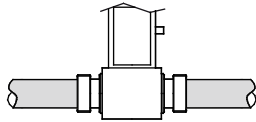

- Observe the upstream and downstream distances.

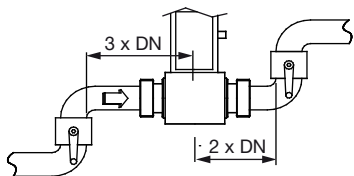

The sensor can be installed into either horizontal or vertical pipes. Mount the sensor in the below as correct indicated ways to obtain an accurate flow measurement.

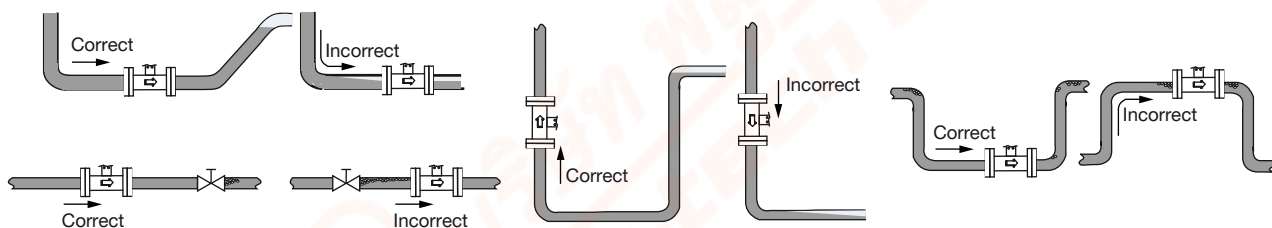

The suitable pipe size can be selected using the diagram for selecting the nominal diameter of the pipe.

See chapter [“4.2. Selection of the nominal diameter”](#) on page 8.

4.2. Selection of the nominal diameter

The graph is used to determine the DN of the pipe and the flowmeter appropriate to the application, according to the fluid velocity and the flow rate. On the chart, the intersection of flow rate and flow velocity gives the appropriate diameter.

Example:

- Flow: 10 l/min
- Optimal flow rate: 2...3 m/s

Result: Select a pipe size of DN 10

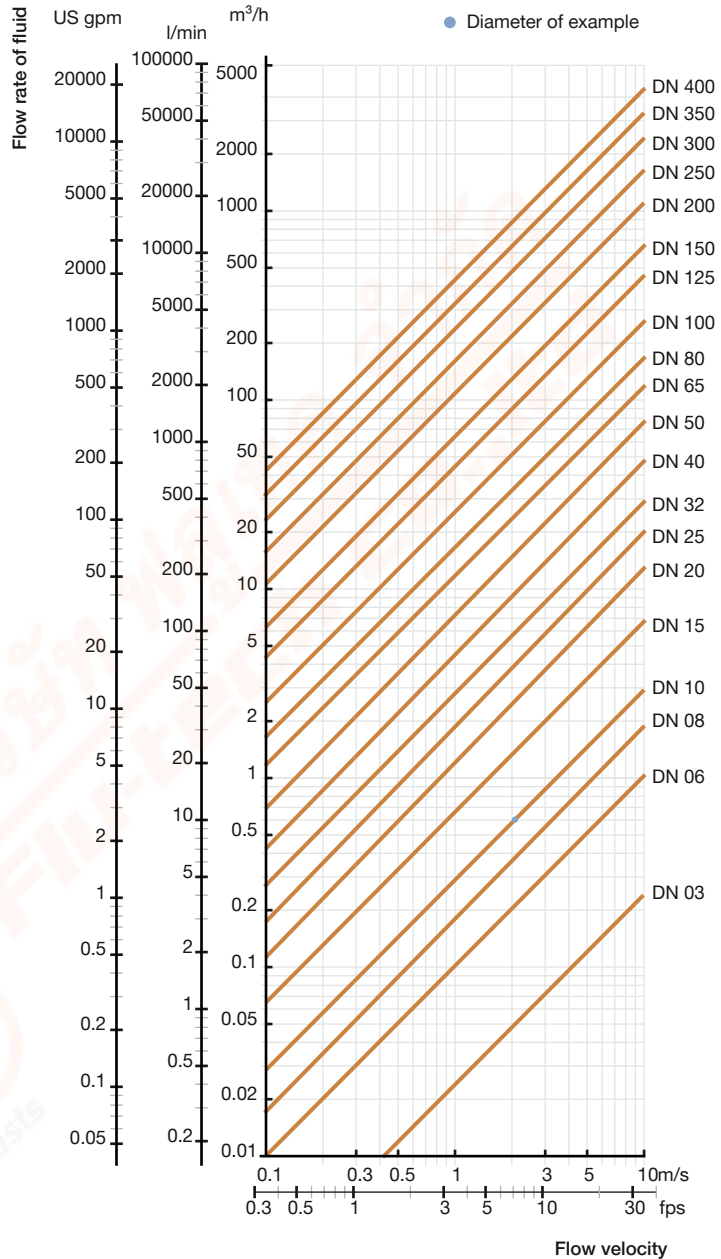

5. Product operation

5.1. Measuring principle

Faraday's law serves as the physical basis for magnetic flow measurement.

Magnetic coils are arranged around the pipeline to generate a magnetic field. Conductive liquids flowing through the magnetic field induce a voltage at two opposite metallic electrodes in contact with the medium. These electrodes are used to measure the induced electrical alternating voltage.

The signal of sensor S054 must be amplified and processed by transmitter SE56. The transmitter delivers a signal proportional to the flow velocity or flow rate at its current output (4...20 mA) or at its pulse output. Depending on the application, both the 4 mA and the 20 mA limits can be assigned values in physical units such as l/min.

6. Ordering information

6.1. Bürkert eShop – Easy ordering and quick delivery



Bürkert eShop – Easy ordering and fast delivery

You want to find your desired Bürkert product or spare part quickly and order directly? Our online shop is available for you 24/7. Sign up and enjoy all the benefits.

[Order online now](#)

6.2. Recommendation regarding product selection

A complete 8054 flowmeter consists of a S054 (compact or remote version) and a SE56 transmitter (compact or remote version).

See [data sheet Type SE56](#) ▶ for more information.

Two different components must be ordered in order to select a complete device. The following information is required:

- **Article no.** of the sensor **Type S054** (see following ordering chart)
- **Article no.** of the transmitter **Type SE56** (see [data sheet Type SE56](#) ▶ for more information)

6.3. Bürkert product filter



Bürkert product filter – Get quickly to the right product

You want to select products comfortably based on your technical requirements? Use the Bürkert product filter and find suitable articles for your application quickly and easily.

[Try out our product filter](#)

6.4. Ordering chart sensor Type S054

DN [mm]	Process connection	Flow rate range		Housing material	Wetted parts materials			Article no.
		Min. 0...0.4 m³/s	Max. 0...10 m³/s		Electrode ^{1.)}	Seal	Lining	
Sensor Type S054, compact version								
25	Wafer type	0...0.72 m³/h	0...18 m³/h	Carbon steel	Stainless steel 316L	FKM	PP	554532
32		0...1.16 m³/h	0...29 m³/h					559435
40		0...1.80 m³/h	0...45 m³/h					554101
50		0...2.88 m³/h	0...72 m³/h					554700
65		0...4.80 m³/h	0...120 m³/h					559436
80		0...7.20 m³/h	0...180 m³/h					554142
100		0...11.20 m³/h	0...280 m³/h					554342
125		0...18.00 m³/h	0...450 m³/h					562953
150	0...25.60 m³/h	0...640 m³/h	562954					
200	Wafer type	0...45.20 m³/h	0...1130 m³/h	Carbon steel	Stainless steel 316L	–	Ebonite (hard rubber)	561912

1.) Three electrodes (2 measuring electrodes + 1 ground electrode)

Further versions on request	
Material <ul style="list-style-type: none"> Seal: EPDM Lining: PTFE Body: stainless steel 304, stainless steel 316L Electrodes: <ul style="list-style-type: none"> Alloy C (2 measuring electrodes + 2 ground electrodes) Titanium (2 measuring electrodes + 2 ground electrodes) Tantalum (2 measuring electrodes + 2 ground electrodes) Platinum-rhodium (2 measuring electrodes + 2 ground electrodes) 	Orifice DN > 200 ^{1.)}
	Pressure PN 10, PN 25, PN 40
	Additional Remote sensor version

1.) Ebonite (hard rubber) or PTFE lining material (if PTFE not selected then Ebonite (hard rubber) in standard)

6.5. Ordering chart accessories

Accessories for remote sensor	No.	Description	Article no.
	1	10 m cable for electrodes ^{1.)} For connecting the sensor (version without junction box) Type S051, S054, S055 or S056 to the connecting box of the cable extension kit.	448518
	2	10 m cable for coils ^{1.)} For connecting the sensor (version without junction box) Type S051, S054, S055 or S056 to the connecting box of the cable extension kit.	448519
	3	10 m cable for electrodes ^{1.)} For connecting <ul style="list-style-type: none"> the connecting box of the cable extension kit to the transmitter Type SE56 the sensor (version with junction box) Type S051, S054, S055 or S056 to the transmitter Type SE56 	562851
	4	10 m cable for coils ^{1.)} For connecting <ul style="list-style-type: none"> the connecting box of the cable extension kit to the transmitter Type SE56 the sensor (version with junction box) Type S051, S054/ S055 or S056 to the transmitter Type SE56 	562852
	5	Connecting box of the cable extension kit including No. 1 + 2 + 3 + 4 and resin	562853

1.) Other cables length than 10 m on request (For cables length > 20 m a preamplifier could be needed. **Caution, this will result in a price increase!**)

DTS 1000425130 EN Version: - Status: RL (released | freigegeben | validé) printed: 27.05.2020