



WWW.FLUTECH.CO.TH



LINE ADD FRIEND @flutech.co.th

Authorized Distributor



# Tuning Fork Level Switch



# CATALOGUE

1. PRODUCT INTRODUCTION.....	1
2. PRODUCT SERIES(1)	
SC14 STANDARD TYPE.....	4
SC17 EX-PROOF TYPE.....	5
SC14 STANDARD TYPE / SC17 EX-PROOF TYPE DESCRIPTION OF FEATURES .....	6
SC14 STANDARD TYPE / SC17 EX-PROOF TYPE WIRING INSTRUCTIONS.....	7
SC14 STANDARD TYPE / SC17 EX-PROOF TYPE MODEL NUMBER / ORDER CODE COMPARISON TABLE.....	8
SC14 STANDARD TYPE / SC17 EX-PROOF TYPE ORDER INFORMATION .....	9
3. PRODUCT SERIES(2)	
SC24 LITE-TYPE.....	11
SC24 LITE-TYPE DESCRIPTION OF FEATURES.....	12
SC24 LITE-TYPE WIRING INSTRUCTIONS.....	14
SC24 LITE-TYPE MODEL NUMBER / ORDER CODE COMPARISON TABLE.....	16
SC24 LITE-TYPE ORDER INFORMATION.....	17
4. PRODUCT SERIES(3)	
SC35 TUNING FORK LEVEL SWITCH .....	18
SC35 TUNING FORK LEVEL SWITCH DESCRIPTION OF FEATURES.....	20
SC35 TUNING FORK LEVEL SWITCH WIRING INSTRUCTIONS .....	21
SC35 TUNING FORK LEVEL SWITCH MODEL NUMBER / ORDER CODE COMPARISON TABLE.....	22
SC35 TUNING FORK LEVEL SWITCH ORDER INFORMATION.....	23
5. PRODUCT SERIES(4)	
SC28 MINI-TYPE.....	25
SC28 MINI-TYPE DESCRIPTION OF FEATURES.....	28
SC28 MINI-TYPE WIRING INSTRUCTIONS .....	30
SC28 MINI-TYPE MODEL NUMBER / ORDER CODE COMPARISON TABLE.....	32
SC28 MINI-TYPE ORDER INFORMATION.....	33
6. PRODUCT SERIES(5)	
SC38 MULTI-FUNCTIONAL TUNING FORK LEVEL SWITCH.....	35
SC38 MULTI-FUNCTIONAL TUNING FORK LEVEL SWITCH DESCRIPTION OF FEATURES.....	37
SC38 MULTI-FUNCTIONAL TUNING FORK LEVEL SWITCH WIRING INSTRUCTIONS.....	39
SC38 MULTI-FUNCTIONAL TUNING FORK LEVEL SWITCH MODEL NUMBER / ORDER CODE COMPARISON TABLE.....	40
SC38 MULTI-FUNCTIONAL TUNING FORK LEVEL SWITCH ORDER INFORMATION.....	41

# PRODUCT INTRODUCTION

## WORKING PRINCIPLE

The SC series is a vibrating tuning fork point level sensor that utilizes piezoelectric crystal and solidstate electronics technology to produce vibration in the tuning fork element at a specific frequency and receive electronic feedback. When the probe element is in contact with the target material, the vibration is dampened, the electronic feedback changes, and presence of the material is thereby sensed by the electronics which changes the state of the sensor output to indicate material presence. When the probe element is again free of the target material, the vibration again is produced and the output state reverts to indicate material absence.

## FEATURE

- SPDT Relay output, SSR MOSFET output.
- Wide voltage supply range 20~250 Vac/Vdc,50/60Hz
- No frequent calibration required, easy-to-use, sturdy and durable design. High/low failure safe mode, safe and reliable.
- Sensitivity adjustment is available for different densities of media. Fine powder can be detected.
- Suitable for liquid, powder, and solid application.
- Dual insulation can reduce damage on the PCB board caused by great changes in temperature and humidity, as well as condensation effects (SC3□ series).
- It can be tested by pressing the test button after installation (SC3□ series).
- Output switch delay function (SC3□ series).
- Self-diagnosis mechanism can detect the abnormality such as the abrasion of the tuning fork or the material viscosity (SC3□ series).
- The compact built-in wiring box can save the installation space (SC3□ series).
- The wiring box can rotate 270 degrees, facilitating adjustment of the inlet direction (SC3□ series).
- The minimum measurable specific gravity can reach 0.01 g/cm<sup>3</sup> (SC35 series).
- Ultra protection mechanism can set the secondary output contact point as alarm output (SC35 series).
- Support the function of detecting underwater sediments (SC35 series).
- All-in-one design, 3/4" (SC38 ), 1" thread is suitable for the installation of a small tube.
- Adjustment setting for different densities of media  $P > 0.5 \text{ g/cm}^3$  or  $\rho. 0.7 \text{ g/cm}^3$  (SC38).
- Switch delay setting function (SC3□ series).
- Alarm indicators based on failure status or output status selected according to the customer's habits (SC3□ series).
- Automatic calibration of the operation points for different densities of media as required by the customer (SC38).

## APPLICABLE MATERIALS

The tuning fork level switch can be widely applied to detect the min. and max. level in tanks, silos and hoppers filled with materials of different densities and state. The following is a list of applications.

### POWDER

- |                        |                        |
|------------------------|------------------------|
| 1. Powdered milk       | 15. Pellets            |
| 2. Frozen potato chips | 16. Peanuts            |
| 3. Beans               | 17. Tobacco            |
| 4. Sugar               | 18. Wood shavings      |
| 5. Sweets              | 19. Chalk              |
| 6. Coffee beans        | 20. Stearin chips      |
| 7. Coffee powder       | 21. Powdered cellulose |
| 8. Frozen dry coffee   | 22. Glass fine power   |
| 9. Tea                 | 23. Granular plastics  |
| 10. Salt               | 24. Gravel             |
| 11. Flour              | 25. Powdered clay      |
| 12. Foundry sand       | 26. Polystyrene powder |
| 13. Spices             | 27. Styrofoam          |
| 14. Animal food        | 28. Soda               |

### LIQUID

1. Water & Solutions
2. General Purpose Solvent
3. Soy sauce
4. Heavy oil
5. Petroleum
6. Oil
7. Ink
8. Cream
9. Drink & Beverage
10. Corrosive liquid

## APPLICATION SCOPE

It is applicable to the max. and min. level detection of the tanks or tubes filled with various solid/liquid media. The product has a variety of applications, such as in the chemical fiber industry, rubber industry, tire industry, cement industry, steel industry, food industry, pharmaceutical industry, and animal feed factories in terms of the level detection for the bins of the raw material/process/finished products.

# APPLICATION EXAMPLE

Application situation	SC24	SC28	SC14X	SC17X	SC35X	SC38X
Liquid	★	★	★	★		★
Powder	★		★	★	★	
Solid					★	
Corrosive media			Optional			
Explosion proof				★	★	★
Tri-Clamp connection	Optional	Optional	Optional			Optional
Operation temp. 100°C	★	★				
Operation temp. 130°C			★	★		
Operation temp. 150°C					★	★
Operation temp. 280°C					★	
Max. pressure<25bar					★	
Max. pressure<40bar	★	★	★	★		★

# PRODUCT DIMENSIONS

<p><b>SC24 Series tri clamp ferrule connection</b></p> <p>Standard type      Extended type</p>	<p><b>SC28 Series tri clamp ferrule connection</b></p> <p>Standard type      Ultra Extension type</p>
<p><b>SC14 Series tri clamp ferrule connection</b></p> <p>Standard type      Extended type</p>	<p><b>SC38 Series tri clamp ferrule connection</b></p> <p>Standard type      Ultra Extension type</p>
<p><b>SC14 Series flange connection</b></p> <p>L: As marked in spec. table</p> <p>L: By requested</p>	<p><b>SC38 Series flange connection</b></p> <p>L: As marked in spec. table</p> <p>L: By requested</p>

# SC14 STANDARD TYPE

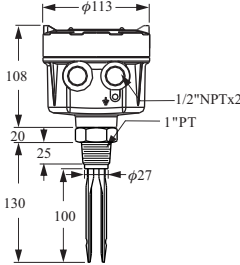
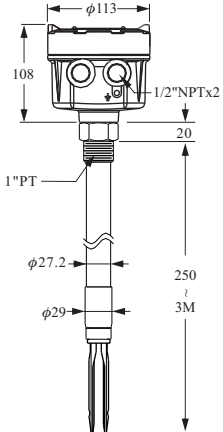
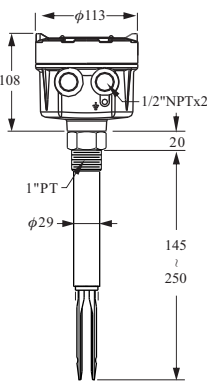
<p>Dimensions (Unit:mm)</p>			
<p>Model No.</p>	<p><b>SC1400 Standard Type</b></p>	<p><b>SC1410 Tuning Fork Ultra Extension Type</b></p>	<p><b>SC1420 Tuning Fork Extension Type</b></p>
<p>Level sensor housing</p>	<p>Aluminum / IP65</p>		
<p>Probe material</p>	<p>SUS 304 / 316 / 316L</p>		
<p>Mounting</p>	<p>1"PT</p>		
<p>Conduit</p>	<p>1/2"NPT × 2</p>		
<p>Max. vertical load on rod.</p>	<p>177in.Lbs(20Nm)</p>		
<p>Process pressure.</p>	<p>-1~600PSI (40bar)</p>		
<p>Power supply</p>	<p>20~250Vac / Vdc,50 / 60Hz</p>		
<p>Power consumption</p>	<p>10VA</p>		
<p>Ambient temp.</p>	<p>-40°C~60°C</p>		
<p>Process temp.</p>	<p>-40°C~130°C</p>		
<p>Signal output</p>	<p>Relay, SPDT, 5A/250Vac, 1 set or 2 set SSR(MOSFET) 400mA/60 Vac / Vdc, 1 set or 2 set</p>		
<p>Min. material density sensed</p>	<p>Solid: ≥0.07g/cm<sup>3</sup>, Liquid: ≥0.7g/cm<sup>3</sup></p>		
<p>Time delay</p>	<p>0.6 Second / Operate; 1~3 Seconds / Reset</p>		
<p>Vibrating frequency.</p>	<p>350~370Hz</p>		
<p>Selectable Fail-safe</p>	<p>Hi. / Lo.</p>		
<p>Selectable sensitivity</p>	<p>Hi. / Lo.</p>		

# SC17 EX-PROOF TYPE

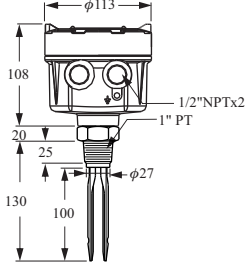
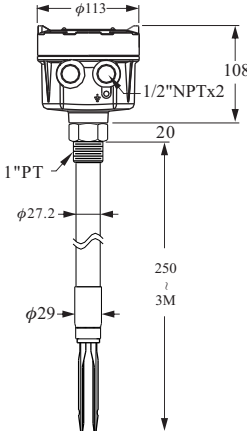
<p>Dimensions (Unit:mm)</p>		
<p>Model No.</p>	<p><b>SC1740 Standard Type</b></p>	<p><b>SC1741 Tuning Fork Ultra Extension Type</b></p>
<p>Level sensor housing</p>	<p>Aluminum / IP65</p>	
<p>Probe material</p>	<p>SUS 304 / 316 / 316L</p>	
<p>Mounting</p>	<p>1"PT</p>	<p>1"PT</p>
<p>Conduit</p>	<p>1/2"NPT×2</p>	
<p>Max. vertical load on rod.</p>	<p>177in.Lbs(20Nm)</p>	
<p>Process pressure.</p>	<p>-1~600PSI (40bar)</p>	
<p>Power supply</p>	<p>20~250,50/60Hz Vac/Vdc</p>	
<p>Power consumption</p>	<p>10VA</p>	
<p>Ambient temp.</p>	<p>-20°C~70°C</p>	
<p>Process temp.</p>	<p>-40°C~125°C</p>	
<p>Signal output</p>	<p>Relay, SPDT, 3A / 250Vac, 1 set or 2 set SSR(MOSFET) 400mA/60 Vac / Vdc, 1 set or 2 set</p>	
<p>Min. material density sensed</p>	<p>Solid: ≥0.07g/cm<sup>3</sup>, Liquid: ≥0.7g/cm<sup>3</sup>, viscosity : 1~10000 cSt</p>	
<p>Time delay</p>	<p>0.6 Second / Operate; 1~3 Seconds / Reset</p>	
<p>Vibrating frequency.</p>	<p>350~370Hz</p>	
<p>Selectable Fail-safe</p>	<p>Hi. / Lo.</p>	
<p>Selectable sensitivity</p>	<p>Hi. / Lo.</p>	

# SC14 STANDARD TYPE / SC17 EX-PROOF TYPE

## DESCRIPTION OF FEATURES

### FORK TRIGGER POINT

SC14/SC17 fork trigger point is shown as below figure.  
The testing medium is water(S.G.=1 g/cm<sup>3</sup>),  
and its trigger point is about 23mm from the fork tip.  
If testing medium with S.G (specific gravity) lower than  
1g/cm<sup>3</sup> (water), the trigger point would increase.  
Similarly, the trigger point will downward while the S.G  
is large than water.

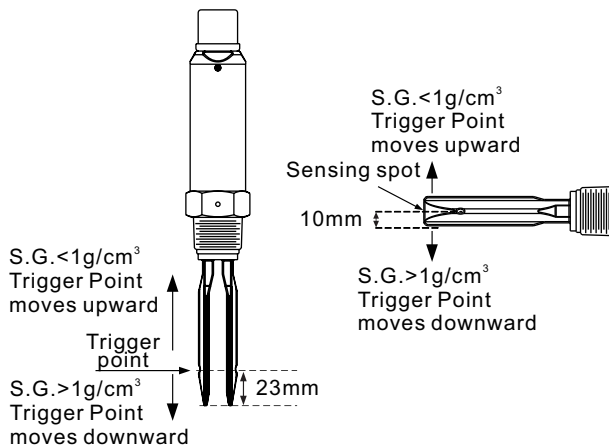



# SC14 STANDARD TYPE / SC17 EX-PROOF TYPE WIRING INSTRUCTIONS

## SC14XX, SC174X

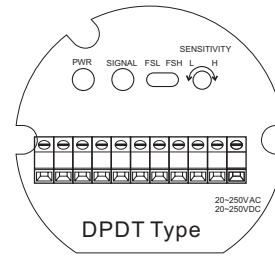
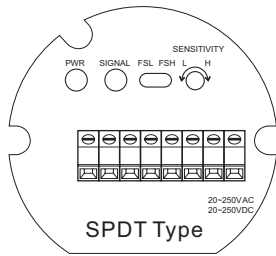

Relay output type(SPDT)

SSR(MOSFET) output type

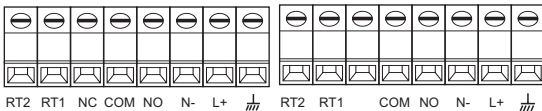

Relay output type (DPDT)

SSR(MOSFET) output type



## FUNCTIONAL DESCRIPTION

### Description of terminal functions

- L+, N-: Power Supply
- NC, COM, NO: Relay Output
- RT1, RT2: Remote-Test
- $\perp$  : Ground Connection
- COM1, NO1 : SSR(MOSFET) Output
- COM2, NO2 : The second set of SSR (MOSFET) output (Optional)

## DESCRIPTION OF PANEL FUNCTIONS

- PWR: Power Supply (Green Light)
- SIGNAL: Output Indication (Red Light)
- FSH: Power On. The signal lamp is on and the relay is conductive. While the tuning fork switch senses the material, the signal lamp is off and relay is not conductive.
- FSL: Power On. The signal lamp is off and the relay is not conductive. While the tuning fork switch senses the material, the signal lamp is on and relay is conductive.
- SENSITIVITY L: Low Sensitivity
- SENSITIVITY H: High Sensitivity

## FAIL-SAFE HIGH / LOW PROTECTION

### FSH (Fail-Safe High) Protection:

Switch to FSH mode.

**Normal Status:** The signal lamp is on. It indicates that the tuning fork switch does not sense the material and the relay is conductive.

**Failure:** When the power shuts down, the signal lamp is off. It indicates that the tuning fork switch is voided and the relay is not conductive.

### FSL (Fail-Safe Low) Protection:

Switch to FSL mode.

**Normal Status:** The signal lamp is on.

The tuning fork switch senses the material and the relay is conductive.

**Failure:** When the power shuts down, the signal lamp is off. The tuning fork switch is voided and the relay is not conductive.

## SENSITIVITY ADJUSTMENT

The SENSITIVITY is located on the right side of the panel. Minor adjustment can be made by rotating the sensitivity up to 22 turns using a small screw driver. Rotating clockwise will increase sensitivity; rotating counter-clockwise will decrease sensitivity.

The sensitivity is originally set at max. value. The switching point is at 15mm from the tip of the tuning fork. The switching point position will be changed by the sensitivity value. If the sensitivity adjusts to lower value, the switching point position is moving backward; if the sensitivity adjusts to high value, the switching point position is moving forward. User may change the switching point position by adjusting the sensitivity. The changing range of switching point is about 60mm. For example, if the switching point needs to be moved backward by 30mm, the user needs to adjust SENSITIVITY counter-clockwise by 10 turns. In general cases, there is no need for sensitivity adjustment.

	FSL		FSH	
Level				
Contact form	NO COM NC	NO COM NC	NO COM NC	NO COM NC
Indication	○	☀	☀	○
Status	Fail	Normal	Normal	Fail

# SC14 STANDARD TYPE / SC17 EX-PROOF TYPE MODEL NUMBER / ORDER CODE COMPARISON TABLE

---

---

---

---

---

---

---

---

Model Number	Order Code
SC1400	SCX10000-AAB
SC1410	SCX10000-CAB
SC1420	SCX10000-BAB
SC1740	SCX1001C-AAB
SC1741	SCX1001C-CAB

# SC14 STANDARD TYPE / SC17 EX-PROOF TYPE ORDER INFORMATION

SCX1 <sup>05</sup> <sup>06</sup> <sup>07</sup> <sup>08</sup> <sup>09</sup> - <sup>12</sup> <sup>13</sup> <sup>14</sup> <sup>15</sup> <sup>16</sup> <sup>17</sup> <sup>18</sup> <sup>19</sup> <sup>20</sup> <sup>21</sup> <sup>22</sup> <sup>23</sup> <sup>24</sup> <sup>25</sup> <sup>26</sup> A B

**<sup>05</sup> <sup>06</sup> Model**

- 00: Standard
- 03: Sanitary

**<sup>07</sup> <sup>08</sup> Certification**

- 00: None
- 1C: ATEX-Ex d
- 2C: IECEx-Ex d
- 7C: NEPSI-Ex d
- 5C: TS-Ex d

**<sup>09</sup> Construction**

- A: Standard
- B: Extension type
- C: Ultra extension type
- D: Cable type
- E: Anti-Corrosion probe type
- F: Anti-Corrosion extension probe type
- G: Sanitary joint type

**<sup>12</sup> Power supply**

- C: 20~250Vac/Vdc, 50/60Hz ; Relay O/P - Euro terminal
- D: 20~250Vac/Vdc, 50/60Hz ; SSR(MOSFET) - Euro terminal
- E: 20~250Vac/Vdc, 50/60Hz ; Relay O/P\*2 - Euro terminal
- F: 20~250Vac/Vdc, 50/60Hz ; SSR(MOSFET)\*2 - Euro terminal

**Connection**

<sup>13</sup> <sup>14</sup>

- Flange
- AK: JIS-FF
- AN: ANSI-RF
- AS: DIN-FF
- AI: 3A

Thread

- AA: JIS
- AC: ANSI

<sup>15</sup> <sup>16</sup>

- A8: 1"
- A9: 1-1/4"
- B1: 1-1/2"
- B2: 2"
- B4: 2-1/2"
- B5: 3"
- B7: 4"
- D8: DN25
- E1: DN40

<sup>17</sup> <sup>18</sup>

- 01: PT male
- 03: PF male
- 07: NPT male
- 40: 5 kg/cm<sup>2</sup>
- 42: 10 kg/cm<sup>2</sup>
- 48: 150 Lbs
- 49: 300 Lbs
- 57: PN10
- 58: PN16

(Next page)

# SC14 STANDARD TYPE / SC17 EX-PROOF TYPE ORDER INFORMATION

SCX1 <sup>05</sup>□<sup>06</sup>□<sup>07</sup>□<sup>08</sup>□<sup>09</sup>□ - <sup>12</sup>□<sup>13</sup>□<sup>14</sup>□<sup>15</sup>□<sup>16</sup>□<sup>17</sup>□<sup>18</sup>□<sup>19</sup>□<sup>20</sup>□<sup>21</sup>□<sup>22</sup>□<sup>23</sup>□<sup>24</sup>□<sup>25</sup>□<sup>26</sup>□

<sup>19</sup> <sup>20</sup> **Probe material**

MA: SUS304  
MB: SUS316  
MC: SUS316L

<sup>21</sup> <sup>22</sup> **Coating material**

00: None  
14: PFA  
34: ECTFE  
※ Coating length max. 400mm

<sup>23</sup> <sup>24</sup> <sup>25</sup> <sup>26</sup> **Probe length**

Code	Probe length
0130~3000	130~3000mm
0105~0250	105~250mm

# SC24 LITE-TYPE

<p>Dimensions (Unit:mm)</p>	<p>Standard Type      Extension Type</p>	<p>Standard Type      Extension Type</p>	<p>Standard Type      Extension Type</p>
<p>Model no.</p>	<p><b>SC24□□□</b> <b>DIN Connector</b></p>	<p><b>SC24□□□</b> <b>M12 Connector</b></p>	<p><b>SC24□□□</b> <b>Cable Wire Type</b></p>
<p>Supply voltage &amp; output</p>	<p>SC240□□: 20~250Vac / Vdc 2 Wire Contactless electronic switch.          SC24P□□: 12~55Vdc 3 Wire PNP output.          SC24N□□: 12~55Vdc 3 Wire NPN output.</p>		
<p>Fork length</p>	<p>100mm</p>		
<p>Ambient temp.</p>	<p>-40~85°C</p>		
<p>Ambient humidity</p>	<p>80% RH non-condensed</p>		
<p>Process temp.</p>	<p>SC24□□□T: -40~+150°C          SC24□□□: -40~+100°C</p>		
<p>Process pressure</p>	<p>Maximum 40 bar</p>		
<p>Min. material density sensed</p>	<p>Solid:density: <math>\geq 0.07\text{g/cm}^3</math>          Liquid:density: <math>\geq 0.7\text{g/cm}^3</math> Viscosity: 1~10000 cSt</p>		
<p>Magnetic testing</p>	<p>Output function test performed by putting magnets near the indicated spot</p>		
<p>Vibrating frequency</p>	<p>350~370Hz</p>		
<p>Status indication</p>	<p>Green light: indicate power supply          Red light: indicate operating mode</p>		
<p>Housing material</p>	<p>SUS304</p>		
<p>Probe material</p>	<p>SUS304, SUS316, SUS316L</p>		
<p>IP protection</p>	<p>IP65</p>	<p>IP67</p>	<p>IP67</p>
<p>Mounting</p>	<p>1" more</p>		
<p>Conduit</p>	<p>Valve plug DIN 43650</p>	<p>M12 Connector(180° / 90°)</p>	<p>Cable connector</p>

# SC24 LITE-TYPE DESCRIPTION OF FEATURES

## FORK TRIGGER POINT

SC24 fork trigger point is shown as below figure.

The testing medium is water (S.G.=1 g/cm<sup>3</sup>), and its trigger point is about 23mm from the fork tip. If testing medium with S.G (specific gravity) lower than 1g/cm<sup>3</sup> (water), the trigger point would increase. Similarly, the trigger point will downward while the S.G is large than water.

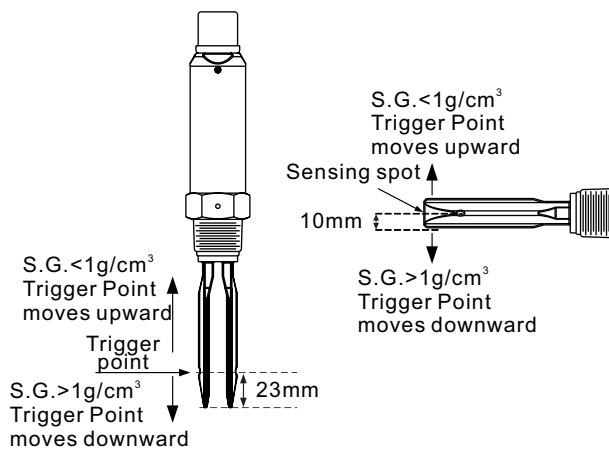

## MAGNETIC TEST

After the switch is installed and powered, magnetic test function can be performed accordingly. The testing point is marked on the housing label. User holds the magnet and moves it close to testing point, the output status will switch from NO. to NC. or NC to NO. and red LED would switch ON or OFF while fork continues to vibrate. When magnet is pulled away from the testing point, the output status and red LED would return as default while fork continues to vibrate. The purpose of testing is to confirm the wiring and functioning are correct.

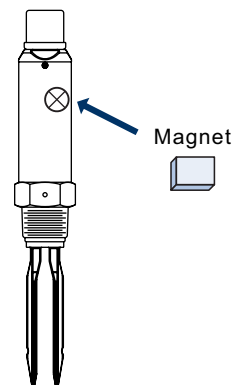

# SC24 LITE-TYPE DESCRIPTION OF FEATURES

## OUTPUT STATUS FOR RELAY

- Low (Min.) Mode: Tuning fork switch will be active after 3 seconds while power on. Relay is on NO status and red LED indication is off. When tuning fork is covered by testing medium, the vibration will stop and relay becomes NC status. Red LED indication then is on.
- High(Max.) Mode: Tuning fork switch will be active after 3 seconds while the power on. Relay is on NC status and red LED indication is on. When tuning fork covered by testing medium, the vibration stops and relay becomes NO status. Red LED indication is on.
- Flashing red indicates abnormal: Possible causes overloads or short-circuit load back, equipment malfunction or wear tuning fork probe.

	Min. Mode		Max.Mode		
Level					Instrument failure
Contactless electronic switch	Switch open	Switch closed	Switch closed	Switch open	Switch open
Red LED					

It represents Blinking

## OUTPUT STATUS FOR PNP / NPN TRANSISTOR

### DIN & Cable type

- Low(Min.) Mode: Tuning fork switch will be active after 3 seconds while power on. Output transistor is on NO status and red LED indication is on. When tuning fork covered by testing medium,vibration will stop and output transistor becomes NC status. Red LED indication is off.
- High(Max.) Mode: Tuning fork switch will be active after 3 seconds while power on. Output transistor is on NC status and red LED indication is on. When tuning fork covered by testing medium,vibration will stop and output transistor becomes NO status. Red LED indication is off.
- Flashing red indicates abnormal: Possible causes overloads or short-circuit load back, equipment malfunction or wear tuning fork probe.

### M12 x 4Pin type

- Low(Min.) Mode: Tuning fork switch will be actuated 3 seconds after the power is on. Relay is NO and red LED indication is off. When tuning fork is covered by testing medium, vibration stops and relay becomes NC. Red LED indication is on.
- High(Max.) Mode: Tuning fork switch will be actuated 3 seconds after the power is on. Relay is NC and red LED indication is off. When tuning fork is covered by testing medium, vibration stops and relay becomes NO. Red LED indication is on.
- Flashing red indicates abnormal: Possible causes overloads or short-circuit load back, equipment malfunction or wear tuning fork probe.

	Min. Mode		Max.Mode		
Level					Instrument failure
PNP/NPN Output	Switch open	Switch closed	Switch closed	Switch open	Switch open
Red LED (DIN& Cable)					
Red LED (M12x 4Pin)					

It represents Blinking

# SC24 LITE-TYPE WIRING INSTRUCTIONS

## SC240X(TWO WIRES) WIRING

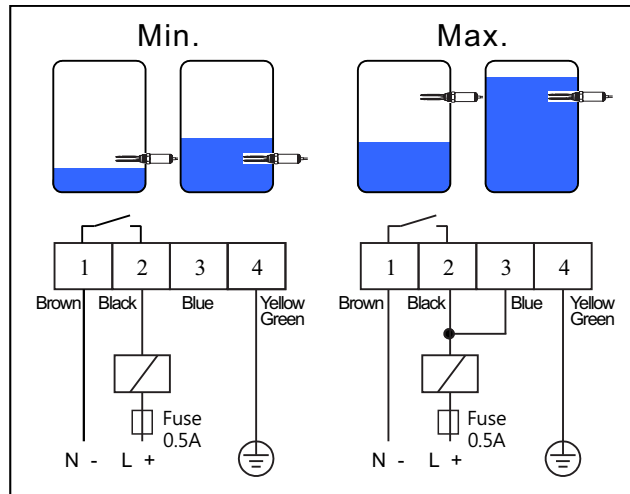
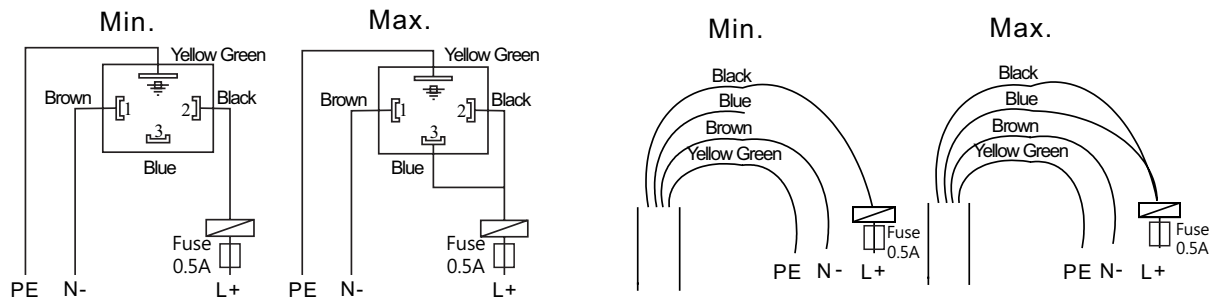

Figure 1 Two Wires Wiring



DIN Wiring Diagram

M12x4Pin Cable Wiring Diagram

### WIRING

Power can be AC/DC switching. Two wires are connected with terminals (L+/N-) as in Figure 1.

#### ■ Low (Min.) mode:

Pin 1 (Brown) is connected to N-. Pin 2 (Black) is connected to L+ with relay. Pin 4 (Yellow Green) connects to tank ground.

#### ■ High (Max.) mode:

Pin 1 (Brown) is connected to N-. Pin 3 is connected to pin 2 (Black) to L+ with Relay. Pin 4 (Yellow Green) connects to tank ground.



# SC24 LITE-TYPE WIRING INSTRUCTIONS

## SC24P/N(THREE WIRES) WIRING

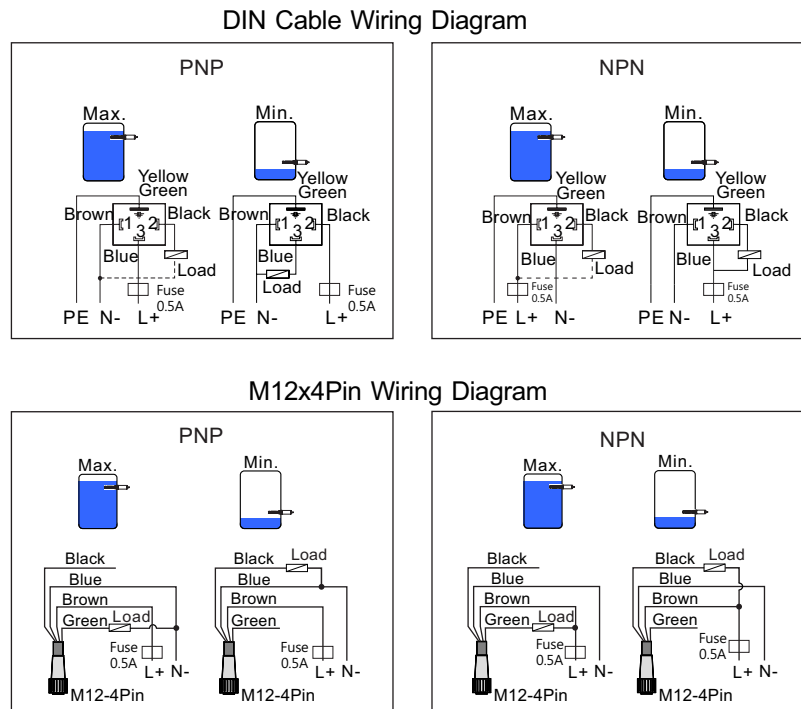

Figure 2 PNP / NPN Output Wiring Diagram

### WIRING

Power supply is for DC only. Output is PNP / NPN and high / low level alarm. Please see Figure 2.

#### ► DIN & Cable Wiring

##### PNP Output

- High (Max.) Mode: Pin 1(Brown) connects to N-. Pin 3 (Blue) connects to L+. To output, it is pin 2. (Black) connects to N- with relay. Pin 4 (Yellow Green) connects to tank ground.
- Low (Min.) Mode: Pin 1 (Brown) connects to N-. Pin 2 (Black) connects to L+. To output, Pin 3 (Blue) connects to N- with relay. Pin 4 (Yellow Green) should contact to tank ground.

##### NPN Output

- High (Max.) Mode: Pin 1 (Brown) connects to L+. Pin 3 (Blue) connects to N-. To output, Pin 2 (Black) connects to L+ with relay. Pin 4(Yellow Green) should contact to tank ground.
- Low(Min.)Mode: Pin1 (Brown) connects to N-. Pin 3 (Blue) connects to L+. To output Pin 2 (Black) connects to L+ with relay. Pin 4 (Yellow Green) should contact To tank ground.

#### ► M12 x 4Pin Wiring:

##### PNP Output

- High(Max.) Mode: No. 1 pin(Brown) is connected to L+. No.3 pin(Blue) is connected to N-. Output is connected to No. 2 pin(Green), then connected to N-.
- Low(Min.) Mode: number 1 pin(Brown) is connected to L+. No.3 pin(Blue) is connected to N-. Output is connected to No. 4 pin(Black), then connected to N-.

##### NPN Output

- High(Max.) Mode: No. 1 pin(Brown) is connected to L+. No.3 pin(Blue) is connected to N-. Output is connected to No. 2 pin(Green), then connected to L+.
- Low(Min.) Mode: No. 1 pin(Brown) is connected to L+. No.3 pin(Blue) is connected to N-. Output is connected to No. 4 pin(Black), then connected to L+.

# SC24 LITE-TYPE MODEL NUMBER / ORDER CODE COMPARISON TABLE

Model Number	Order Code
SC2400	SCX2□□00-□BA
SC240□□T	SCX20200-□BA
SC24P□	SCX2□□00-□BP
SC24N□	SCX2□□00-□BN

# SC24 LITE-TYPE ORDER INFORMATION

SCX2 ⑤ ⑥ ⑨ ⑩ ⑪ ⑫ ⑬ ⑭ ⑮ ⑯ ⑰ ⑱ ⑲ ⑳ ㉑ ㉒ ㉓ ㉔

**⑤ ⑥ Model**

00: Standard      02: Hi-temperature

**⑨ Construction**

A: Standard      B: Extension type

**⑩ Fork length**

B: 100mm

**⑪ Power supply**

A: 20~250Vac/Vdc, 50/60Hz; 2 wire Contactless electronic switch  
 P: 12~55Vdc ; 3 Wire PNP output.  
 N: 12~55Vdc ; 3 Wire NPN output.

**Connection**

⑫ ⑬

Flange  
 AK: JIS-FF  
 AN: ANSI-RF  
 AS: DIN-FF  
 AI: 3A

⑭ ⑮

A8: 1"  
 A9: 1-1/4"  
 B1: 1-1/2"  
 B2: 2"  
 B4: 2-1/2"  
 B5: 3"  
 B7: 4"  
 D8: DN25  
 E1: DN40

⑯ ⑰

01: PT male  
 03: PF male  
 07: NPT male  
 40: 5 kg/cm<sup>2</sup>  
 42: 10 kg/cm<sup>2</sup>  
 48: 150 Lbs  
 49: 300 Lbs  
 57: PN10  
 58: PN16

**⑱ ⑲ Probe material**

MA: SUS304  
 MB: SUS316  
 MC: SUS316L

**⑳ Connection**

A: M12x1(180°)      C: Cable  
 B: M12x1(90°)      D: DIN 43650

※M12x1 with Cable, standard cable length 2M, PVC 24AWG

**㉑ ㉒ ㉓ ㉔ Probe length**

Code	Probe length
0130~0250	130~250mm

# SC35 TUNING FORK LEVEL SWITCH

NEPSI Ex tD A21 IP66/67 T85~T300°C  
IECEX Ex ta IIIC T95°C / T130°C / T136°C Da  
Ex tb IIIC T80°C / T95°C / T130°C / T160°C / T240°C / T290°C Db

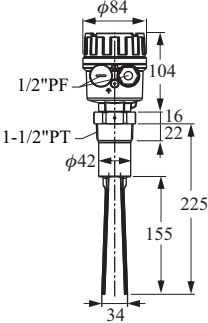
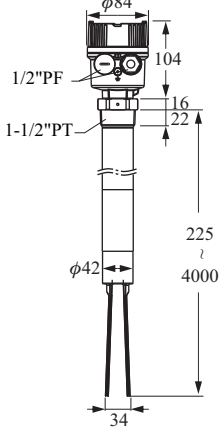
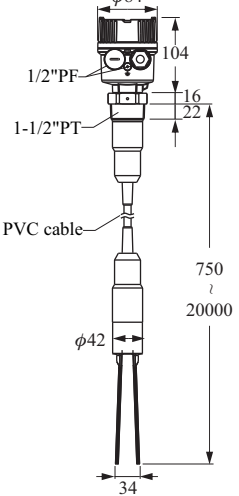
Dimensions (Unit:mm)			
Model No.	<b>SC350 Standard Type</b>	<b>SC351 Extension Type</b>	<b>SC352 Cable Type</b>
Level sensor housing	Built-in box, aluminum coating IP66/IP67		
Probe material	SUS 304 / 316 / 316L		
Power supply	19 ~253 Vdc / Vac, 50/60 Hz ; NPN / PNP(10~55Vdc)		
Probe construction	Max. 1.5 W		
Voltage endurance capability	3.7 kV		
Overvoltage protection	overvoltage category II		
Ambient temp.	-40~85 °C		-40~75 °C
Process temp.	-40~150 °C	-40~150 °C	-40~80 °C
Material density	≥ 0.01 g/cm <sup>3</sup> or ≥ 0.05 g/cm <sup>3</sup>		
Measuring frequency	140 Hz ± 5 Hz		
Material dimension	Max.10 mm		
Conduit	1/2"PF / 1/2"NPT(Ex-proof type only supports 1/2"NPT)		
External diameter of conduit cable	φ6~φ10 mm		
Process pressure	Max.25 bar		Max. 2 bar
Output signal	2 sets of SPDT relay output / 2 sets of transistor output / 3 wires NPN/PNP transistor output		
Contact capacity	Relay: 6A / 250Vac , 6A / 28Vdc ; Transistor: 350mA , 60Vac / Vdc NPN / PNP / Transistor: 350mA , 55Vdc		

# SC35 TUNING FORK LEVEL SWITCH

NEPSI Ex tD A21 IP66/67 T85~T300°C  
IECEX Ex ta IIIC T95°C / T130°C / T136°C Da  
Ex tb IIIC T80°C / T95°C / T130°C / T160°C / T240°C / T290°C Db

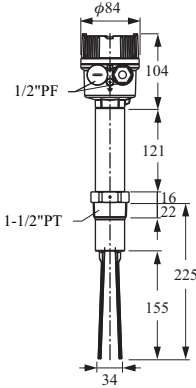
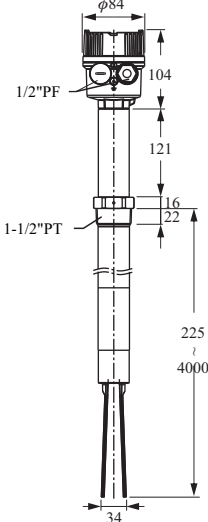
Dimensions (Unit:mm)		
Model No.	<b>SC350 High-temp. Type</b>	<b>SC351 High-temp. Extension Type</b>
Level sensor housing	Built-in box, aluminum coating IP66/IP67	
Probe material	SUS 304 / 316 / 316L	
Power supply	19 ~253 Vdc / Vac, 50/60 Hz	
Probe construction	Max. 1.5 W	
Voltage endurance capability	3.7 kV	
Overvoltage protection	overvoltage category II	
Ambient temp.	-40~85 °C	
Process temp.	-40~280 °C	
Material density	$\geq 0.01 \text{ g/cm}^3$ or $\geq 0.05 \text{ g/cm}^3$	
Measuring frequency	140 Hz $\pm$ 5 Hz	
Material dimension	Max.10 mm	
Conduit	1/2"PF / 1/2"NPT(Ex-proof type only supports 1/2"NPT)	
External diameter of conduit cable	$\phi 6\sim\phi 10$ mm	
Process pressure	Max. 25 bar	
Output signal	2 sets of SPDT relay output / 2 sets of transistor output	
Contact capacity	Relay: 6A / 250Vac , 6A / 28Vdc Transistor: 350mA , 60Vac / Vdc	

# SC35 TUNING FORK LEVEL SWITCH DESCRIPTION OF FEATURES

## PANEL INTRODUCTION

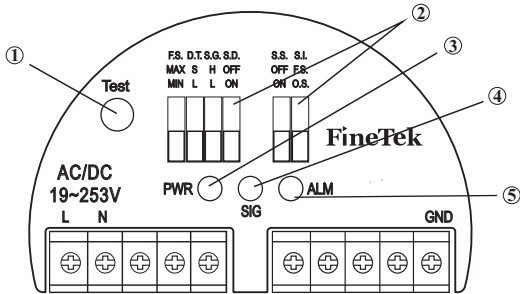

- ①: Test button
- ②: Function adjustment button
- ③: Power indicator
- ④: Status indicator
- ⑤: Alarm indicator

Abbreviation	Function	Option description	Remarks
Test	Test button	Reverse output signal	Reverse output signal can be used to provide a method for testing control equipment which is connected to sensor output
F.S.	Fail-Safe	MAX: High MIN: Low	Includes high low fail-safe mode
D.T.	Delay Time	S: General setting L: Delay of 5 seconds	Material covered: 0.5s Material not covered: 150°C: ≤1.5s 230°C / 280°C: ≤2s L sets delay of 5s for covered/uncovered
S.G.	Specific Gravity	H: ≥0.05 g/cm <sup>3</sup> L: ≥0.01 g/cm <sup>3</sup>	High Density >0.05 g/cm <sup>3</sup> Low Density >0.01 g/cm <sup>3</sup>
S.D.	Self Diagnosis	OFF: Disabled ON: Enabled	ON setting allows the sensor to detect for abrasion or material build-up; SIG LED will flash if trouble exists
S.S.	Super Switch	OFF: Disabled ON: Enabled	When set ON Output 2 will be dedicated to indicate self-diagnostics alarm exists
S.I.	Signal Indication	F.S.: Fail-Safe mode O.S.: Output status mode	F.S. (fail safe) selected = Normal / Alarm status; O.S. (relay output status) selected = Relay energized (on) or de-energized (off)

## SEDIMENT DETECTION

- It is only used to detect the sediment under the water, but can't be used for the level detection of the liquid or the doped liquid.
- S.G. (Specific Gravity) shall be adjusted to H position.
- S.D. (Self Diagnosis) shall be switched to OFF position.
- SC352 cable type is inapplicable to this working environment

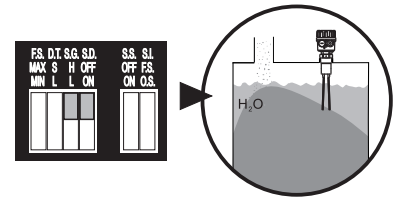

## ENVIRONMENT/PROCESS TEMPERATURE LIMITATION

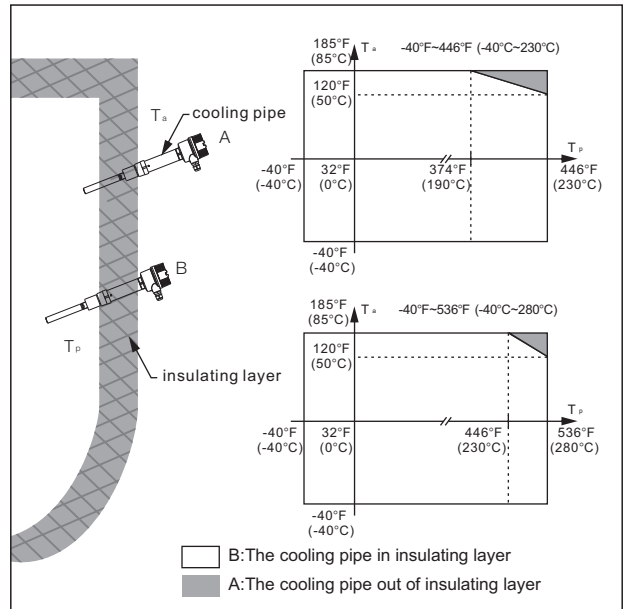
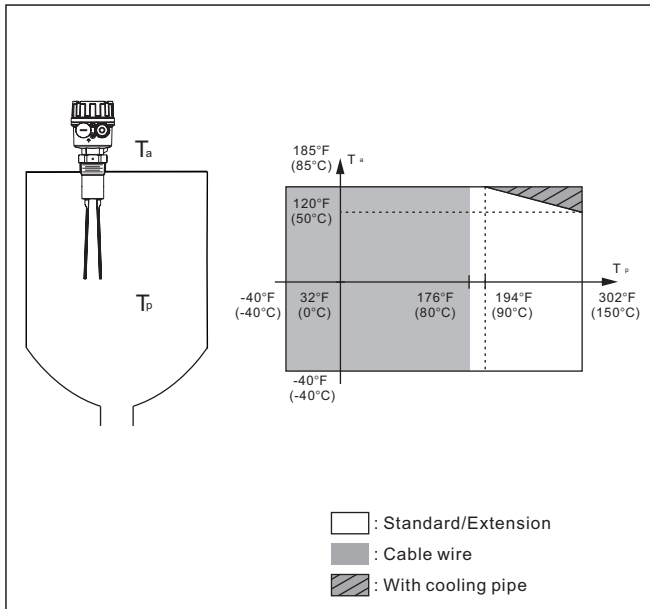

- ※ ETFE coating:  $T_p$  max. = 150°C
- ※ PTFE coating:  $T_p$  max. = 230°C

# SC35 TUNING FORK LEVEL SWITCH WIRING INSTRUCTIONS

## WIRING CONFIGURATION DIAGRAM AND INTRODUCTION OF FEATURES

Dual-relay output

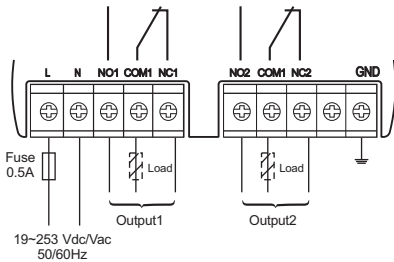

Load: External load  
 $U \sim \text{max. } 250\text{Vac}@I_L \sim \text{max. } 6\text{A}$   
 $U = \text{max. } 28\text{Vdc}@I_L = \text{max. } 6\text{A}$

Failure mode	Material level	Output signal			LED indicators		
		output1	output2		Power	Status	Alarm
			S.S. OFF	S.S. ON	Green	Yellow	Red
MAX							
MIN							
Viscous material		Maintain the previous state					
Wear of tuning fork							

Dual-transistor output

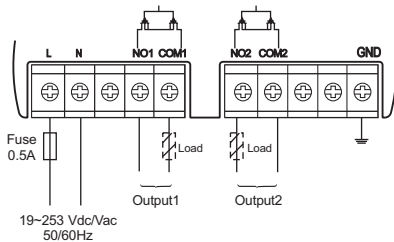

Load: External load  
 $U \sim \text{max. } 60\text{Vac}@I_L \sim \text{max. } 350\text{mA}$   
 $U = \text{max. } 60\text{Vdc}@I_L = \text{max. } 350\text{mA}$   
 ※ External load R must be connected

Failure mode	Material level	Output signal			LED indicators		
		output1	output2		Power	Status	Alarm
			S.S. OFF	S.S. ON	Green	Yellow	Red
MAX							
MIN							
Viscous material		Maintain the previous state					
Wear of tuning fork							
Output1>350mA			Maintain the previous state				
Output2>350mA		Maintain the previous state					
Output1 & Output2>350mA							

※ When output is off, there will be no error current status

: ON    : Flash    : OFF

: Relay ON    : Relay OFF     $I_L$  : Load current

# SC35 TUNING FORK LEVEL SWITCH MODEL NUMBER / ORDER CODE COMPARISON TABLE

---

---

---

---

---

---

---

---

---

---

Model Number	Order Code
SC350	SCX3□□□□-EC(HC,JC)
SC351	SCX3□□□□-FC(IC,KC)
SC352	SCX3□□□□-DC



# SC35 TUNING FORK LEVEL SWITCH ORDER INFORMATION

SCX3  <sup>05</sup>  <sup>06</sup>  <sup>07</sup>  <sup>08</sup> -  <sup>09</sup>  <sup>10</sup>  <sup>11</sup>  <sup>12</sup>  <sup>13</sup>  <sup>14</sup>  <sup>15</sup>  <sup>16</sup>  <sup>17</sup>  <sup>18</sup>  <sup>19</sup>  <sup>20</sup>  <sup>21</sup>  <sup>22</sup>  <sup>23</sup>  <sup>24</sup>  <sup>25</sup>  <sup>26</sup>  <sup>27</sup>  <sup>28</sup>

**05 06 Model**

- 00: Standard  
(Construction: A, B, D)
- 02: High temperature  
(Construction: E, F)
- 08: High temperature  
(Construction: H, I)
- 09: High temperature type 2  
(Construction: J, K)

**07 08 Certification**

- 01: None; 1/2" PF
- 02: None; 1/2" NPT
- 03: None; M20x1.5
- 2D: IECEEx-Ex t; 1/2"NPT
- 5D: TS-Ex t; 1/2" NPT
- 7B: NEPSI-Ex ia; 1/2" NPT
- 7D: NEPSI-Ex d; 1/2" NPT

**09 Construction**

- A: Standard (150°C @ 50°C)
- B: Extension type (150°C @ 50°C)
- D: Cable type (80°C)
- E: High temperature general type  
(150°C @ 85°C)
- F: High temperature extension type  
(150°C @ 85°C)
- H: High temperature type (230°C)
- I: High temperature extension type (230°C)
- J: High temperature type 2 (280°C)
- K: High temperature extension type 2 (280°C)

**10 Fork length**

- C: 155mm

**11 Housing**

- F: Aluminum
- R: Stainless steel (No explosion protection)

**12 Housing cover**

- A: No Lens
- B: Lens(Only stainless steel)

(Next page)

# SC35 TUNING FORK LEVEL SWITCH

## ORDER INFORMATION

SCX3 <sup>05</sup> <sup>06</sup> <sup>07</sup> <sup>08</sup> - <sup>09</sup> <sup>10</sup> <sup>11</sup> <sup>12</sup> <sup>13</sup> <sup>14</sup> <sup>15</sup> <sup>16</sup> <sup>17</sup> <sup>18</sup> <sup>19</sup> <sup>20</sup> <sup>21</sup> <sup>22</sup> <sup>23</sup> <sup>24</sup> <sup>25</sup> <sup>26</sup> <sup>27</sup> <sup>28</sup>

**⑬ Power supply**

- A: 19~253Vac/Vdc, 50/60Hz; Two relay output
- B: 19~253Vac/Vdc, 50/60Hz; Two transistor output
- C: 10~55Vdc; 3 wire PNP/NPN output

**Connection**

<sup>14</sup> <sup>15</sup>	<sup>16</sup> <sup>17</sup>	<sup>18</sup> <sup>19</sup>
Flange	B1: 1-1/2"	01: PT male
AK: JIS-FF	B2: 2"	03: PF male
AN: ANSI-RF	B4: 2-1/2"	07: NPT male
AS: DIN-FF	B5: 3"	40: 5 kg/cm <sup>2</sup>
AI: 3A	B7: 4"	42: 10 kg/cm <sup>2</sup>
	D8: DN25	48: 150 Lbs
Thread	E1: DN40	49: 300 Lbs
AA: JIS		57: PN10
AC: ANSI		58: PN16

**⑳㉑ Probe material**

- MA: SUS304
- MB: SUS316
- MC: SUS316L

**㉒㉓ Coating material**

- 00: None
- 36: ETFE
- ※ Coating length max. 400mm

**㉔ Surface roughness**

- A: Ra ≤ 3.2um

**㉕㉖㉗㉘ Probe length**

Code	Probe length
0225~4000	225~4000mm
0750~A200	750~20000mm

# SC28 MINI-TYPE

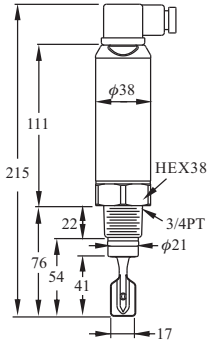
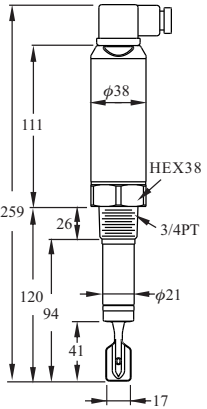
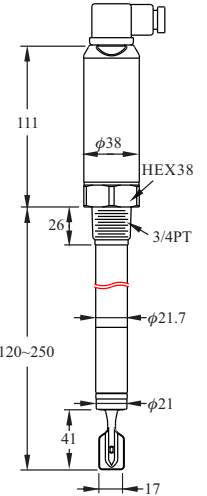
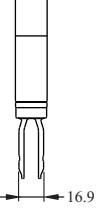
<p>Dimensions (Unit:mm)</p>	 <p>Standard Type</p>	 <p>Extension Type</p>	 <p>Ultra Extension Type</p>	 <p>Side View</p>
<p>Model no.</p>	<p>SC28□□□ DIN Connector</p>			
<p>Supply voltage &amp; output</p>	<p>SC280□: 20~250 Vac / Vdc, 50/60Hz 2 wire Contactless electronic switch. SC28P□□: 12~55Vdc 3wire PNP output; SC28N□□: 12~55Vdc 3wire NPN output.</p>			
<p>Fork length</p>	<p>40mm</p>			
<p>Ambient temp.</p>	<p>-40°C~80°C</p>			
<p>Ambient humidity</p>	<p>SC28□□□: -40°C~100°C SC28□□□T: -40°C~150°C</p>			
<p>Process temp.</p>	<p>80% RH non-condensed</p>			
<p>Process pressure</p>	<p>-1~600PSI (40bar)</p>			
<p>Min. material density sensed</p>	<p>Liquid:density: <math>\geq 0.7\text{g/cm}^3</math> Viscosity: 1~10000 cSt</p>			
<p>Magnetic testing</p>	<p>Output function test performed by putting magnets near the indicated spot</p>			
<p>Vibrating frequency</p>	<p>1K Hz <math>\pm 10\%</math></p>			
<p>Status indication</p>	<p>Green light:indicate power supply Red light:indicate operating mode</p>			
<p>Housing material</p>	<p>SUS304</p>			
<p>Probe material</p>	<p>SUS304, SUS316, SUS316L</p>			
<p>IP protection</p>	<p>IP65</p>			
<p>Mounting</p>	<p>3/4"more</p>			
<p>Conduit</p>	<p>Valve plug DIN 43650</p>			

# SC28 MINI-TYPE

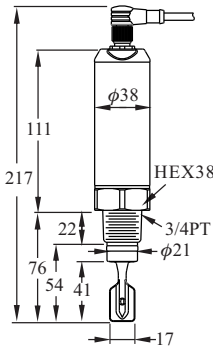
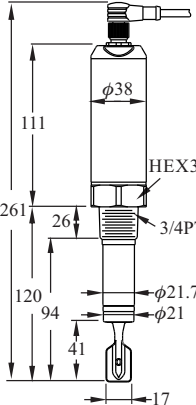
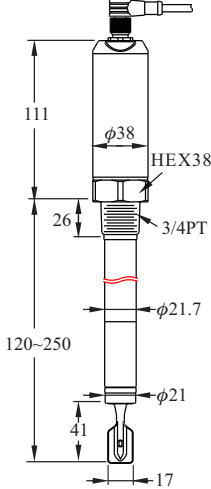
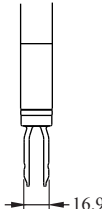
<p>Dimensions (Unit:mm)</p>	 <p>Standard Type</p>	 <p>Extension Type</p>	 <p>Ultra Extension Type</p>	 <p>Side View</p>
<p>Model no.</p>	<p>SC28□□□ M12 Connector</p>			
<p>Supply voltage &amp; output</p>	<p>SC280□: 20~250 Vac / Vdc, 50/60Hz 2 wire Contactless electronic switch.          SC28P□□: 12~55Vdc 3wire PNP output; SC28N□□: 12~55Vdc 3wire NPN output.</p>			
<p>Fork length</p>	<p>40mm</p>			
<p>Ambient temp.</p>	<p>-40°C~80°C</p>			
<p>Ambient humidity</p>	<p>SC28□□□: -40°C~100°C          SC28□□□T: -40°C~150°C</p>			
<p>Process temp.</p>	<p>80% RH non-condensed</p>			
<p>Process pressure</p>	<p>-1~600PSI (40bar)</p>			
<p>Min. material density sensed</p>	<p>Liquid:density: <math>\geq 0.7\text{g/cm}^3</math> Viscosity: 1~10000 cSt</p>			
<p>Magnetic testing</p>	<p>Output function test performed by putting magnets near the indicated spot</p>			
<p>Vibrating frequency</p>	<p>1K Hz <math>\pm 10\%</math></p>			
<p>Status indication</p>	<p>Green light: indicate power supply          Red light: indicate operating mode</p>			
<p>Housing material</p>	<p>SUS304</p>			
<p>Probe material</p>	<p>SUS304, SUS316, SUS316L</p>			
<p>IP protection</p>	<p>IP67</p>			
<p>Mounting</p>	<p>3/4"more</p>			
<p>Conduit</p>	<p>M12 Connector(180° / 90°)</p>			

# SC28 MINI-TYPE

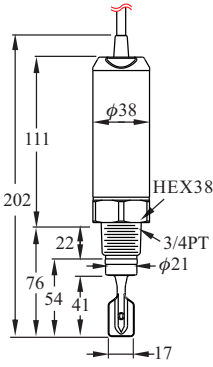
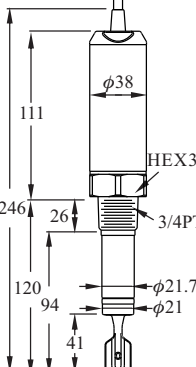
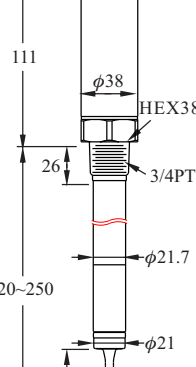
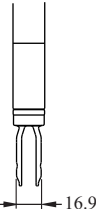
<p>Dimensions (Unit:mm)</p>	 <p>Standard Type</p>	 <p>Extension Type</p>	 <p>Ultra Extension Type</p>	 <p>Side View</p>
<p>Model no.</p>	<p>SC28□□□ Cable Wire Type</p>			
<p>Supply voltage &amp; output</p>	<p>SC280□:20~250 Vac / Vdc, 50/60Hz 2 wire Contactless electronic switch. SC28P□□: 12~55Vdc 3wire PNP output; SC28N□□: 12~55Vdc 3wire NPN output.</p>			
<p>Fork length</p>	<p>40mm</p>			
<p>Ambient temp.</p>	<p>-40°C~80°C</p>			
<p>Ambient humidity</p>	<p>SC28□□□: -40°C~100°C SC28□□□T: -40°C~150°C</p>			
<p>Process temp.</p>	<p>80% RH non-condensed</p>			
<p>Process pressure</p>	<p>-1~600PSI (40bar)</p>			
<p>Min. material density sensed</p>	<p>Liquid:density: <math>\geq 0.7\text{g/cm}^3</math> Viscosity: 1~10000 cSt</p>			
<p>Magnetic testing</p>	<p>Output function test performed by putting magnets near the indicated spot</p>			
<p>Vibrating frequency</p>	<p>1K Hz <math>\pm 10\%</math></p>			
<p>Status indication</p>	<p>Green light:indicate power supply Red light:indicate operating mode</p>			
<p>Housing material</p>	<p>SUS304</p>			
<p>Probe material</p>	<p>SUS304, SUS316, SUS316L</p>			
<p>IP protection</p>	<p>IP67</p>			
<p>Mounting</p>	<p>3/4"more</p>			
<p>Conduit</p>	<p>Cable connector</p>			

# SC28 MINI-TYPE DESCRIPTION OF FEATURES

---

---

---

---

---

---

---

---

## MAGNETIC TEST

After the switch is installed and powered, magnetic test function can be performed accordingly. The testing point is marked on the housing label. User holds the magnet and moves it close to testing point, the output status will switch from NO. to NC. or NC to NO. and red LED would switch ON or OFF while fork continues to vibrate. When magnet is pulled away from the testing point, the output status and red LED would return as default while fork continues to vibrate. The purpose of testing is to confirm the wiring and functioning are correct.

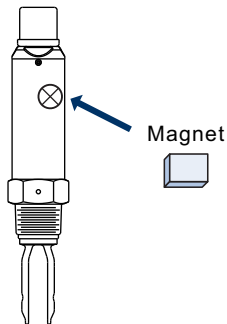

# SC28 MINI-TYPE DESCRIPTION OF FEATURES

## OUTPUT STATUS FOR RELAY

- Low (Min.) Mode: Tuning fork switch will be active after 3 seconds while power on. Relay is on NO status and red LED indication is off. When tuning fork is covered by testing medium, the vibration will stop and relay becomes NC status. Red LED indication then is on.
- High(Max.) Mode: Tuning fork switch will be active after 3 seconds while the power on. Relay is on NC status and red LED indication is on. When tuning fork covered by testing medium, the vibration stops and relay becomes NO status. Red LED indication is on.
- Flashing red indicates abnormal: Possible causes overloads or short-circuit load back, equipment malfunction or wear tuning fork probe.

	Min. Mode		Max. Mode		
Level					Instrument failure
Contactless electronic switch					
Red LED					

It represents Blinking

## OUTPUT STATUS FOR PNP / NPN TRANSISTOR

### DIN & Cable type

- Low(Min.) Mode: Tuning fork switch will be active after 3 seconds while power on. Output transistor is on NO status and red LED indication is on. When tuning fork covered by testing medium, vibration will stop and output transistor becomes NC status. Red LED indication is off.
- High(Max.) Mode: Tuning fork switch will be active after 3 seconds while power on. Output transistor is on NC status and red LED indication is on. When tuning fork covered by testing medium, vibration will stop and output transistor becomes NO status. Red LED indication is off.
- Flashing red indicates abnormal: Possible causes overloads or short-circuit load back, equipment malfunction or wear tuning fork probe.

### M12 x 4Pin type

- Low(Min.) Mode: Tuning fork switch will be actuated 3 seconds after the power is on. Relay is NO and red LED indication is off. When tuning fork is covered by testing medium, vibration stops and relay becomes NC. Red LED indication is on.
- High(Max.) Mode: Tuning fork switch will be actuated 3 seconds after the power is on. Relay is NC and red LED indication is off. When tuning fork is covered by testing medium, vibration stops and relay becomes NO. Red LED indication is on.
- Flashing red indicates abnormal: Possible causes overloads or short-circuit load back, equipment malfunction or wear tuning fork probe.

	Min. Mode		Max. Mode		
Level					Instrument failure
PNP/NPN Output					
Red LED (DIN & Cable)					
Red LED (M12 x 4Pin)					

It represents Blinking

# SC28 MINI-TYPE WIRING INSTRUCTIONS

## SC280(TWO WIRES) WIRING

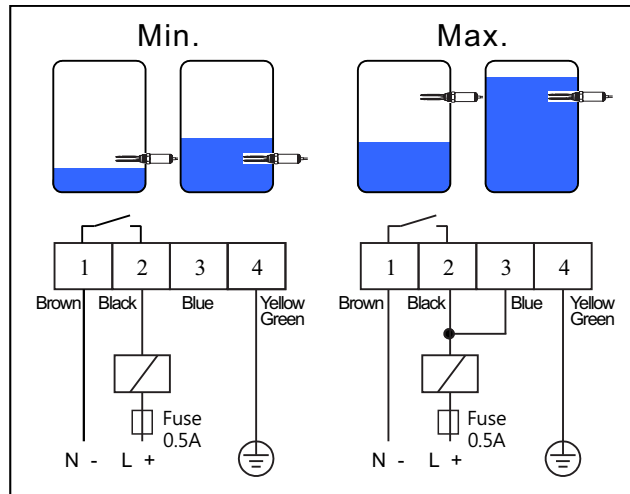
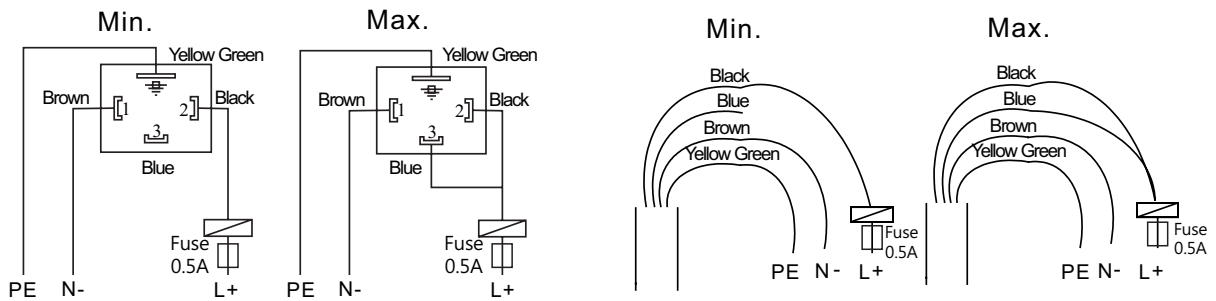

Figure 1 Two Wires Wiring



DIN Wiring Diagram

M12x4Pin Cable Wiring Diagram

### Wiring

Power can be AC/DC switching. Two wires are connected with terminals (L+/N-) as in Figure 1.

#### ■ Low (Min.) mode:

Pin 1 (Brown) is connected to N-. Pin 2 (Black) is connected to L+ with relay. Pin 4 (Yellow Green) connects to tank ground.

#### ■ High (Max.) mode:

Pin 1 (Brown) is connected to N-. Pin 3 is connected to pin 2 (Black) to L+ with Relay. Pin 4 (Yellow Green) connects to tank ground.



# SC28 MINI-TYPE WIRING INSTRUCTIONS

## SC28P/N (THREE WIRES) WIRING

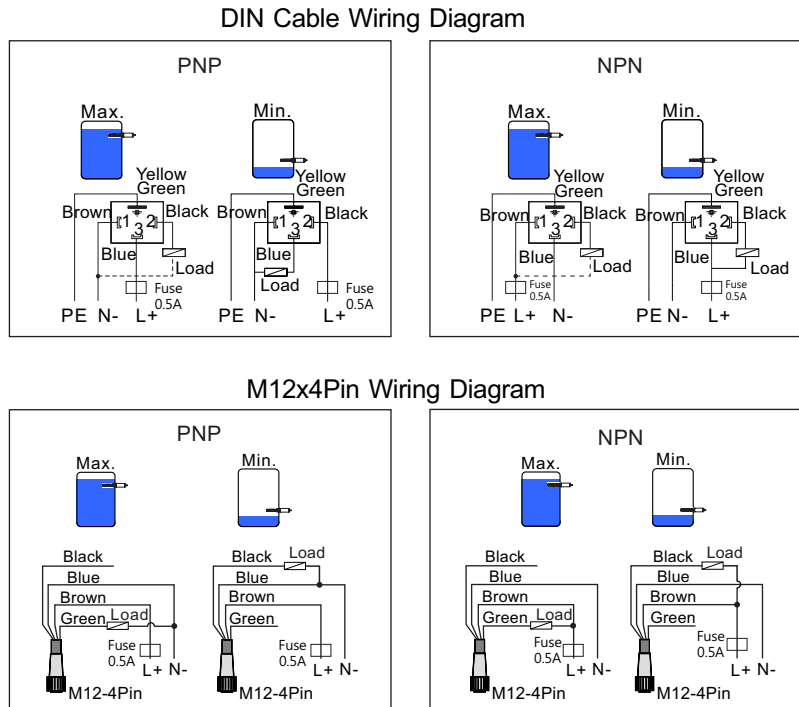

Figure 2 PNP / NPN Output Wiring Diagram

### Wiring

Power supply is for DC only. Output is PNP / NPN and high / low level alarm. Please see Figure 2.

#### ► DIN & Cable Wiring

#### PNP Output

- High (Max.) Mode: Pin 1(Brown) connects to N-. Pin 3 (Blue) connects to L+. To output, it is pin 2. (Black) connects to N- with relay. Pin 4 (Yellow Green) connects to tank ground.
- Low (Min.) Mode: Pin 1 (Brown) connects to N-. Pin 2 (Black) connects to L+. To output, Pin 3 (Blue) connects to N- with relay. Pin 4 (Yellow Green) should contact to tank ground.

#### NPN Output

- High (Max.) Mode: Pin 1 (Brown) connects to L+. Pin 3 (Blue) connects to N-. To output, Pin 2 (Black) connects to L+ with relay. Pin 4(Yellow Green) should contact to tank ground.
- Low(Min.)Mode: Pin1 (Brown) connects to N-. Pin 3 (Blue) connects to L+. To output Pin 2 (Black) connects to L+ with relay. Pin 4 (Yellow Green) should contact To tank ground.

#### ► M12 x 4Pin Wiring:

#### PNP Output

- High(Max.) Mode: No. 1 pin(Brown) is connected to L+. No.3 pin(Blue) is connected to N-. Output is connected to No. 2 pin(Green), then connected to N-.
- Low(Min.) Mode: number 1 pin(Brown) is connected to L+. No.3 pin(Blue) is connected to N-. Output is connected to No. 4 pin(Black), then connected to N-.

#### NPN Output

- High(Max.) Mode: No. 1 pin(Brown) is connected to L+. No.3 pin(Blue) is connected to N-. Output is connected to No. 2 pin(Green), then connected to L+.
- Low(Min.) Mode: No. 1 pin(Brown) is connected to L+. No.3 pin(Blue) is connected to N-. Output is connected to No. 4 pin(Black), then connected to L+.

# SC28 MINI-TYPE MODEL NUMBER / ORDER CODE COMPARISON TABLE

---

---

---

---

---

---

---

---

Model Number	Order Code
SC280□□	SCX50000-□AC□T
SC28P□□	SCX50000-□AC□P
SC28N□□	SCX50000-□AC□N
SC280□□T	SCX50200-□AC□T
SC28P□□T	SCX50200-□AC□P
SC28N□□T	SCX50200-□AC□N

# SC28 MINI-TYPE ORDER INFORMATION

SCX 5 ⑤ ⑥ ⑦ ⑧ - ⑨ ⑩ ⑪ ⑫ ⑬ ⑭ ⑮ ⑯ ⑰ ⑱ ⑲ ⑳ ㉑ ㉒ ㉓ ㉔ ㉕ ㉖ ㉗ ㉘

⑤ ⑥ **Model**

- 00: Standard
- 02: High temperature

⑦ ⑧ **Certification**

- 00: None

⑨ **Construction**

- A: Standard
- B: Extension type
- D: Ultra extension type
- E: High temperature general type
- F: High temperature extension type
- G: High temperature ultra extension type

⑩ **Fork length**

- A: 40mm

⑪ **Housing**

- C: Compact

⑫ **Housing cover**

- C: Cable
- D: DIN43650
- M: M12x1(180°)
- N: M12x1(90°)
- ※M12x1 with cable, standard cable length 2M, PVC 24AWG

⑬ **Power supply**

- T: 20~250Vac/Vdc, 50/60Hz; 2 wire contactless electronic switch
- P: 12~55Vdc; 3 wire PNP output
- N: 12~55Vdc; 3 wire NPN output

(Next page)

# SC28 MINI-TYPE ORDER INFORMATION

SCX 5 (05)(06)(07)(08)(09)(10)(11)(12)(13)(14)(15)(16)(17)(18)(19)(20)(21)(22)(23)(24)(25)(26)(27)(28)  
-

**Connection**

- |               |            |                          |
|---------------|------------|--------------------------|
| (14) (15)     | (16) (17)  | (18) (19)                |
| AA: JIS       | A7: 3/4"   | 00: None                 |
| AB: ISO       | A8: 1"     | 01: PT male              |
| AC: ANSI/ASTM | A9: 1-1/4" | 03: PF male              |
| AD: DIN       | B1: 1-1/2" | 05: BSP male             |
| AG: IDF       | B2: 2"     | 07: NPT male             |
| AI: 3A        | B3: 2-1/4" | 40: 5kg/cm <sup>2</sup>  |
| AJ: JIS-RF    | B4: 2-1/2" | 42: 10kg/cm <sup>2</sup> |
| AK: JIS-FF    | B5: 3"     | 48: 150Lbs               |
| AN: ANSI-RF   | B6: 3-1/2" | 49: 300Lbs               |
| AO: ANSI-FF   | B7: 4"     | 51: 600Lbs               |
| AR: DIN-RF    | B8: 5"     | 57: PN 10                |
| AS: DIN-FF    | B9: 6"     | 58: PN 16                |
|               | D7: DN20   | 59: PN 25                |
|               | D8: DN25   | 60: PN 40                |
|               | D9: DN32   | 62: PN 0.6 Mpa           |
|               | E1: DN40   | 63: PN 1.0 Mpa           |
|               | E2: DN50   | 64: PN 1.6 Mpa           |
|               | E3: DN65   | 65: PN 2.5 Mpa           |
|               | E4: DN80   | 66: PN 4.0 Mpa           |

(20) (21) **Probe material**

- MA: SUS304
- MB: SUS316
- MC: SUS316L

(22) (23) **Coating material**

00: None

(24) **Surface roughness**

- B: Ra ≤ 1.5um
- C: Ra ≤ 0.8um

(25) (26) (27) (28) **Probe length**

Code	Probe length	Remarks
0054	54mm	Compact-hidden plate type
0076	76mm	Compact-thread type
0098	98mm	Compact-hidden extension type
0120	120mm	Compact-thread extension type
0099~0250	99~250mm	Compact-hidden plate lengthened type
0121~0250	121~250mm	Compact-thread lengthened type

# SC38 MULTI-FUNCTIONAL TUNING FORK LEVEL SWITCH



NEPSI Ex ia IIC T3-T6 Ga

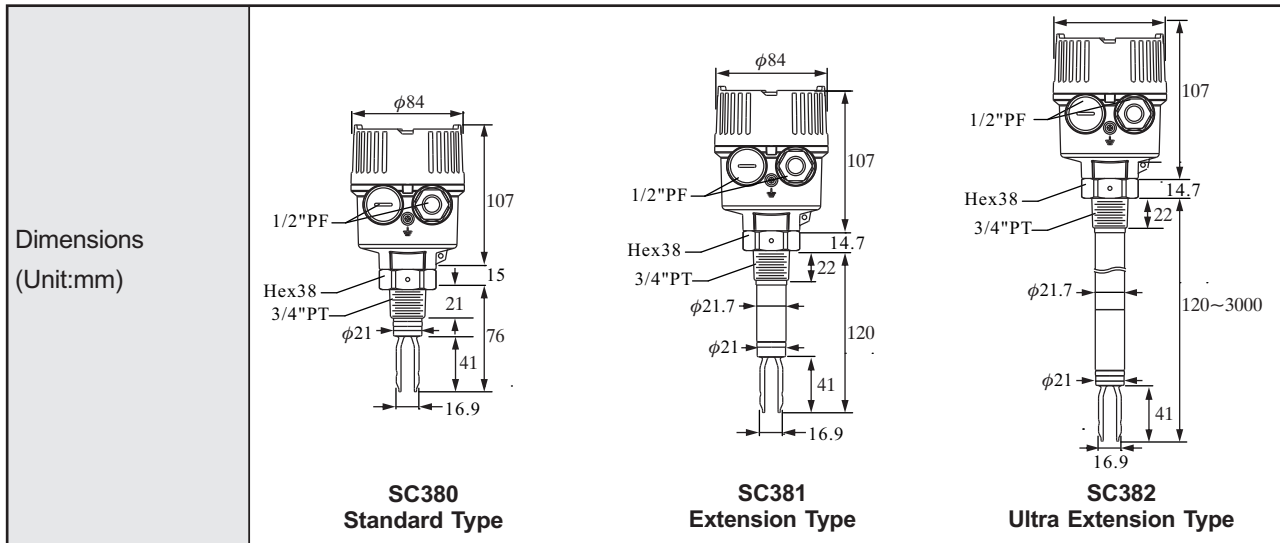

Output type	8/16mA output type	3 Wires (NPN/PNP) output type	Dual-relay output type
Working voltage	11 ~36 Vdc	10 ~55 Vdc	19~253Vac / 2dc,50 / 260Hz
Power consumption	< 600mW	< 830mW	Max. 1.3W
Input protection	Reversed power supply protection function		NA
Overvoltage protection	overvoltage category III		
Measuring error	Max.±1mm		
Repeatability	0.5mm		
Hysteresis band	Approx.2mm		
Ambient temp.	-40~85 °C (Intrinsically safe type -40~70 °C)	-40~85 °C(Refernce operation manual)	
Process temp.	-40~150 °C		
Applicable density liquid	≥0.5 g/cm <sup>3</sup> or ≥0.7 g/cm <sup>3</sup>		
Liquid viscosity	Max.10000mm <sup>2</sup> / S(10000cSt)		
Granule size contained in the liquid	Max.φ5 mm		
External diameter of conduit cable	φ6~φ10 mm		
Process pressure	Max.40 bar		
Output signal	Intrinsically safe signal 8 / 216mA	Transistor output (NPN/PNP)	2 sets of SPDT relay output
Contact capacity	NA	350mA , 55Vdc	6A / 250Vac , 6A / 28Vdc
Protection level	IP66/67		
Probe material	SUS 304 / 2316 / 316L		
Intrinsically safe parameters	Ui(V)=36V , li=100mA, Pi=1W Ci(nF)=0 , Li(uH)=0※	NA	NA

※ Must be equipped with intrinsic safety barrier to form a standard intrinsically safe system (Ex ia), please refer to another DM/brochure for TXX safety barrier.

# SC38 MULTI-FUNCTIONAL TUNING FORK LEVEL SWITCH



NEPSI Ex ia IIC T3~T6 Ga

Dimensions (Unit:mm)			
	<b>SC380</b> High-temp. Type	<b>SC381</b> High-temp. Extension Type	<b>SC382</b> High-temp. Ultra Extension Type

Output type	8/16mA output type	3 Wires (NPN/PNP) output type	Dual-relay output type
Working voltage	11 ~36 Vdc	10 ~55 Vdc	19~253Vac/dc,50/60Hz
Power consumption	< 600mW	< 830mW	Max. 1.3W
Input protection	Reversed power supply protection function		NA
Overvoltage protection	overvoltage category III		
Measuring error	Max.±1mm		
Repeatability	0.5mm		
Hysteresis band	Approx.2mm		
Ambient temp.	-40~85 °C(Refernce operation manual)		
Process temp.	-40~150 °C		
Applicable density liquid	≥0.5 g/cm <sup>3</sup> or ≥0.7 g/cm <sup>3</sup>		
Liquid viscosity	Max.10000mm <sup>2</sup> / S(10000cSt)		
Granule size contained in the liquid	Max.φ5 mm		
External diameter of conduit cable	φ6~φ10 mm		
Process pressure	Max.40 bar		
Output signal	Intrinsically safe signal 8/16mA	Transistor output (NPN/PNP)	2 sets of SPDT relay output
Contact capacity	NA	350mA , 55Vdc	6A / 250Vac , 6A / 28Vdc
Protection level	IP66/67		
Probe material	SUS 304 / 316 / 316L		
Intrinsically safe parameters	Ui(V)=36V , li=100mA,Pi=1W Ci(nF)=0 , Li(uH)=0※	NA	NA

※ Must be equipped with intrinsic safety barrier to form a standard intrinsically safe system (Ex ia), please refer to another DM/brochure for TXX safety barrier.

# SC38 MULTI-FUNCTIONAL TUNING FORK LEVEL SWITCH DESCRIPTION OF FEATURES

## FORK TRIGGER POINT

The position of the SC38 fork trigger point depends on the mounting position as shown in the figure below: (When the testing medium is water, S.G.=1 g/cm<sup>3</sup>, distance of the trigger point is 13mm). If the testing medium has an S.G lower than 1g/cm<sup>3</sup>, the trigger point would rise. Similarly, the trigger point will move downward while the S.G is greater than water. The moving distance is subject to the S.G.

※Operating point position: ◀

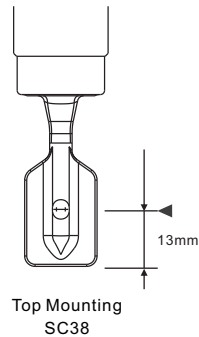

## ENVIRONMENT AND PROCESS TEMPERATURE LIMITATION

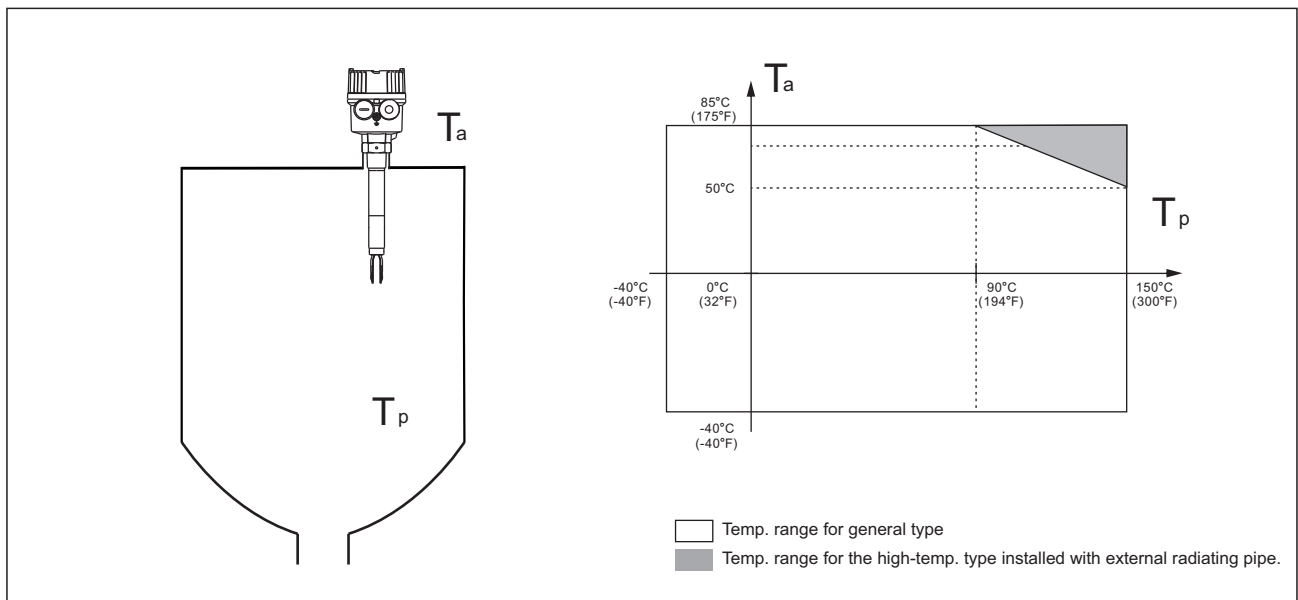

# SC38 MULTI-FUNCTIONAL TUNING FORK LEVEL SWITCH DESCRIPTION OF FEATURES

## PANEL INTRODUCTION

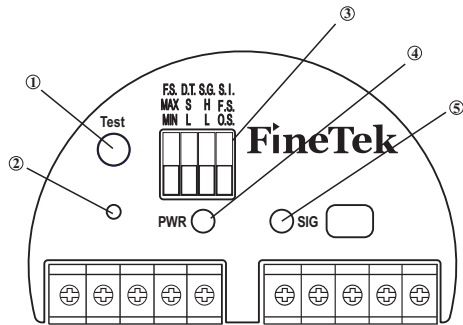

- ①: Test button
- ②: Operation point calibration button
- ③: Function adjustment button
- ④: Power indicator
- ⑤: Status indicator

Abbreviation	Function	Option Description	Remarks
<b>Test</b>	Test button	Reverse the signal output	It is for the test after the installation is completed.
<b>F.S.</b>	Fail-Safe	MAX: High MIN: Low	It is for the high and low Fail-Safe mode.
<b>D.T.</b>	Delay Time	S: General setting L: Delay for 5 seconds	Covered by material: Approx. 0.5s Not covered by material: Approx. 1s Switch to L to set it at 5 seconds for either covered or not covered by material.
<b>S.G.</b>	Specific Gravity	H: $\geq 0.7 \text{ g/cm}^3$ L: $\geq 0.5 \text{ g/cm}^3$	The switch to set the material density.
<b>S.I.</b>	Signal Indication	F.S.: Fail-Safe mode O.S.: Output mode	Turn ON/OFF the yellow indicator based on the output status or the fail-safe status.

## DESCRIPTION OF THE TEST BUTTON

This button is mainly provided for the user to check whether the output operation works normally after the installation is completed. When the button is pressed, the output current (8mA $\leftrightarrow$ 16mA) and indicator (ON $\leftrightarrow$ OFF) will be reversed. Once the button is released, it will recover the original status.

## FUNCTION OF CUSTOMIZED OPERATION POINT POSITION

SC38 provides the function of customizing the operation point position according to what is required by the user.

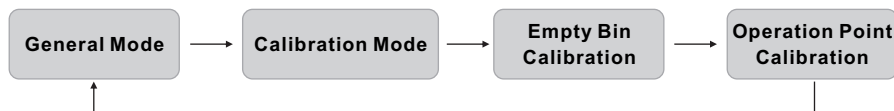

## Settings

1. Keep pressing "Calibration Button" for 3 seconds. When the red and green LED indicators flash every 0.5 second, it enters the calibration mode. Press the calibration button again to enter the Empty Bin Calibration mode.

### [Empty Bin Calibration]

2. Calibration status: The red LED indicator flashes every 0.5 second, and the output current switches to operate every 0.5 second (8 $\leftrightarrow$ 16mA).

3. This mode is to calibrate the vibration frequency of the tuning fork in the air. Press "Calibration Button" when the tuning fork doesn't touch any material. The unit will record the vibration frequency in the air, and enter the operation point calibration mode.

### [Operation Point Calibration]

1. Calibration status: The red LED indicator flashes every 0.25 second, and the output current switches to operate every 0.25 second (8 $\leftrightarrow$ 16mA).

2. Cover the material to the desired operating point position under this mode, and then press "Calibration Button". It will be adjusted to the corresponding operating point position according to the H/L setting of the S.G.



# SC38 MULTI-FUNCTIONAL TUNING FORK LEVEL SWITCH WIRING INSTRUCTIONS

## WIRING CONFIGURATION DIAGRAM AND INTRODUCTION OF FEATURES

8/16mA output

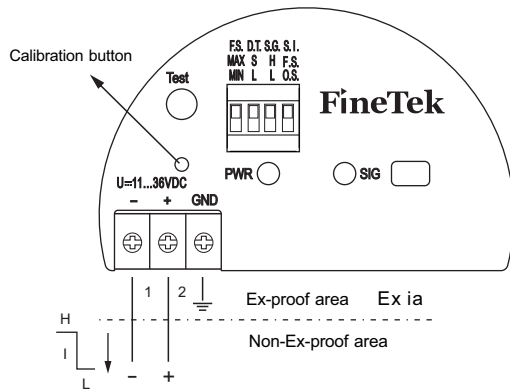

Failure mode	Material level	Output signal	LED indicators
MAX		+ 2 $\xrightarrow{\sim 16mA}$ 1	O.S.  / F.S.
		+ 2 $\xrightarrow{\sim 8mA}$ 1	O.S.  / F.S.
MIN		+ 2 $\xrightarrow{\sim 16mA}$ 1	O.S.  / F.S.
		+ 2 $\xrightarrow{\sim 8mA}$ 1	O.S.  / F.S.
Instrument failure		+ 2 $\xrightarrow{<3.6mA}$ 1	

$\sim 16mA = 16mA \pm 5\%$   
 $\sim 8mA = 8mA \pm 5\%$

: ON : Flash : OFF

PNP/NPN Output

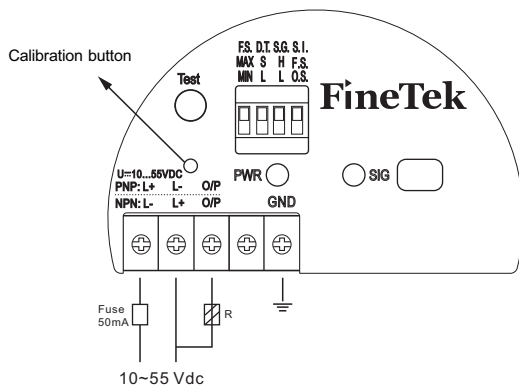

Failure mode	Material level	Output signal	LED indicators
MAX		$\square \xrightarrow{I_L} \square$	O.S.  / F.S.
		$\square \xrightarrow{<100\mu A} \square$	O.S.  / F.S.
MIN		$\square \xrightarrow{I_L} \square$	O.S.  / F.S.
		$\square \xrightarrow{<100\mu A} \square$	O.S.  / F.S.
Instrument failure		$\square \xrightarrow{<100\mu A} \square$	
Over Load ( $I_L > 350mA$ )		$\square \xrightarrow{<100\mu A} \square$	

$I_L$  : Load current

: ON : Flash : OFF

R : External load  
 $U = \max. 55Vdc @ I_L = \max. 350mA$

Dual Relay output

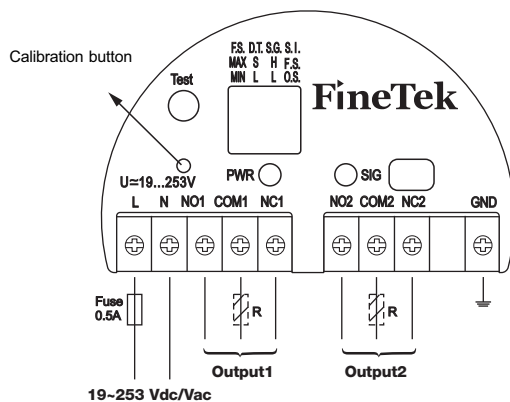

Failure mode	Material level	Output signal	LED indicators	
			PWR	SIG
MAX			O.S.  / F.S.	
			O.S.  / F.S.	
MIN			O.S.  / F.S.	
			O.S.  / F.S.	
Instrument failure				

R: External load  
 $U \sim \max. 250Vac @ I_L \sim \max. 6A$   
 $U = \max. 28Vdc @ I_L = \max. 6A$

: ON : Flash : OFF

# SC38 MULTI-FUNCTIONAL TUNING FORK LEVEL SWITCH MODEL NUMBER / ORDER CODE COMPARISON TABLE

Model Number	Order Code
SC380C□□□□0	SCX500□□-AA
SC380F□□□□0	
SC380G□□□□0	
SC381C□□□□1	SCX500□□-BA
SC381F□□□□1	
SC381G□□□□1	
SC382C□□□□2	SCX500□□-CA
SC382F□□□□2	
SC382G□□□□2	
SC380C□□□□3	SCX502□□-EA
SC380F□□□□3	
SC380G□□□□3	
SC381C□□□□4	SCX502□□-FA
SC381F□□□□4	
SC381G□□□□4	
SC382C□□□□5	SCX502□□-GA
SC382F□□□□5	
SC382G□□□□5	

# SC38 MULTI-FUNCTIONAL TUNING FORK LEVEL SWITCH ORDER INFORMATION

SCX 5  <sup>05</sup>  <sup>06</sup>  <sup>07</sup>  <sup>08</sup> -  <sup>09</sup>  <sup>10</sup>  <sup>11</sup>  <sup>12</sup>  <sup>13</sup>  <sup>14</sup>  <sup>15</sup>  <sup>16</sup>  <sup>17</sup>  <sup>18</sup>  <sup>19</sup>  <sup>20</sup>  <sup>21</sup>  <sup>22</sup>  <sup>23</sup>  <sup>24</sup>  <sup>25</sup>  <sup>26</sup>  <sup>27</sup>  <sup>28</sup>

**05 06 Model** \_\_\_\_\_  
 00: Standard  
 02: High temperature

**07 08 Certification** \_\_\_\_\_  
 01: None, 1/2"PF  
 02: None, 1/2"NPT  
 7B: NEPSI-Ex ia, 1/2"NPT

**09 Construction** \_\_\_\_\_  
 A: Standard  
 B: Extended type  
 D: Ultra extension type  
 E: High temperature general type  
 F: High temperature extension type  
 G: High temperature ultra extension type

**10 Fork length** \_\_\_\_\_  
 A: 40mm

**11 Housing** \_\_\_\_\_  
 F: Shared junction box(Aluminum box)  
 R: Shared junction box(Stainless steel)

**12 Housing cover** \_\_\_\_\_  
 A: Without lens(Shared junction box)  
 B: With lens(Shared junction box)(Only stainless steel)

**13 Power supply** \_\_\_\_\_  
 A: 19~253Vac/Vdc,50/60Hz;Two relay output  
 C: 10~55Vdc;3 wire PNP/NPN output  
 D: 11~36Vdc;8/16mA output

(Next page)

# SC38 MULTI-FUNCTIONAL TUNING FORK LEVEL SWITCH ORDER INFORMATION

SCX 5 ⑤⑥⑦⑧-⑨⑩⑪⑫⑬⑭⑮⑯⑰⑱⑲⑳㉑㉒㉓㉔㉕㉖㉗㉘

**Connection**

- |  |  |   |
|--|--|---|
| <p>⑭ ⑮</p> <p>AA: JIS<br/>AB: ISO<br/>AC: ANSI/ASTM<br/>AD: DIN<br/>AG: IDF<br/>AI: 3A<br/>AJ: JIS-RF<br/>AK: JIS-FF<br/>AN: ANSI-RF<br/>AO: ANSI-FF<br/>AR: DIN-RF<br/>AS: DIN-FF</p> | <p>⑯ ⑰</p> <p>A7: 3/4"<br/>A8: 1"<br/>A9: 1-1/4"<br/>B1: 1-1/2"<br/>B2: 2"<br/>B3: 2-1/4"<br/>B4: 2-1/2"<br/>B5: 3"<br/>B6: 3-1/2"<br/>B7: 4"<br/>B8: 5"<br/>B9: 6"<br/>D7: DN20<br/>D8: DN25<br/>D9: DN32<br/>E1: DN40<br/>E2: DN50<br/>E3: DN65<br/>E4: DN80</p> | <p>⑱ ⑲</p> <p>00: None<br/>01: PT male<br/>03: PF male<br/>05: BSP male<br/>07: NPT male<br/>40: 5kg/cm2<br/>42: 10kg/cm2<br/>48: 150Lbs<br/>49: 300Lbs<br/>51: 600Lbs<br/>57: PN 10<br/>58: PN 16<br/>59: PN 25<br/>60: PN 40<br/>62: PN 0.6 Mpa<br/>63: PN 1.0 Mpa<br/>64: PN 1.6 Mpa<br/>65: PN 2.5 Mpa<br/>66: PN 4.0 Mpa</p> |
|--|--|---|

**㉑ ㉒ Probe material**

- MA: SUS304  
MB: SUS316  
MC: SUS316L

**㉓ ㉔ Coating material**

- 00: None  
36: ETFE

**㉕ Surface roughness**

- B: Ra ≤ 1.5um  
C: Ra ≤ 0.8um

**㉖ ㉗ ㉘ ㉙ Probe length**

Code	Probe length	Remarks
0054	54mm	Shared junction box-hidden plate type
0076	76mm	Shared junction box-thread type
0098	98mm	Shared junction box-hidden extension type
0120	120mm	Shared junction box-thread extension type
0099~3000	99~3000mm	Shared junction box-hidden plate lengthened type
0121~3000	121~3000mm	Shared junction box-thread lengthened type



**บริษัท ฟลูเทค จำกัด**  
**FLU-TECH CO.,LTD**

**845/3-4 หมู่ 3 ถ.เทพารักษ์ ต.เทพารักษ์ อ.เมือง จ.สมุทรปราการ 10270**

845/3-4 Thepharak RD., T.Thepharak, A.Muang, Samutprakarn 10270 THAILAND  
Tel. 0 2384 6060, Fax 0 2384 5701, Email : [pneumatic@flutech.co.th](mailto:pneumatic@flutech.co.th), [www.flutech.co.th](http://www.flutech.co.th)