



## Series 6200 - Twin-rod slide units

### General

#### TWIN-ROD SLIDE UNITS SERIES 6200 AND 6210

The 6200 series twin-rod linear guide units are wide cylinders used in manipulation applications and are characterised by their high force output thanks to their double piston design.

Bores range from 10mm to 32mm diameter, with sintered bronze bearings for standard applications and linear ball bearings for more rugged applications.

One major characteristic of these cylinders is the precision of their anti-rotational design, with the possibility of regulating the stroke to within 0.5mm.

When using magnetic sensors, the 1580 series sensor sits entirely within the extrusion, resulting in a smooth profile.

The liner guided units range includes , alongside the conventional two rod version with flange series 6200 , also the through rod version with twin flanges series 6210

Thanks to the twin-rod, double yoke design of the 6210 series it is possible to either fix the body and use the ends of the rods, or alternatively to fix the rod ends and use the body as the moving part. The cylinder can be piped through the body or through the rods depending on the application.

Stroke limiting screws are fitted at either end of the stroke. The substitution of these screws with shock absorbers makes it possible to use the cylinder on higher velocity applications (up to 500mm/sec.) Slots are provided along the edge of these units to accommodate 1580 series miniature sensors.

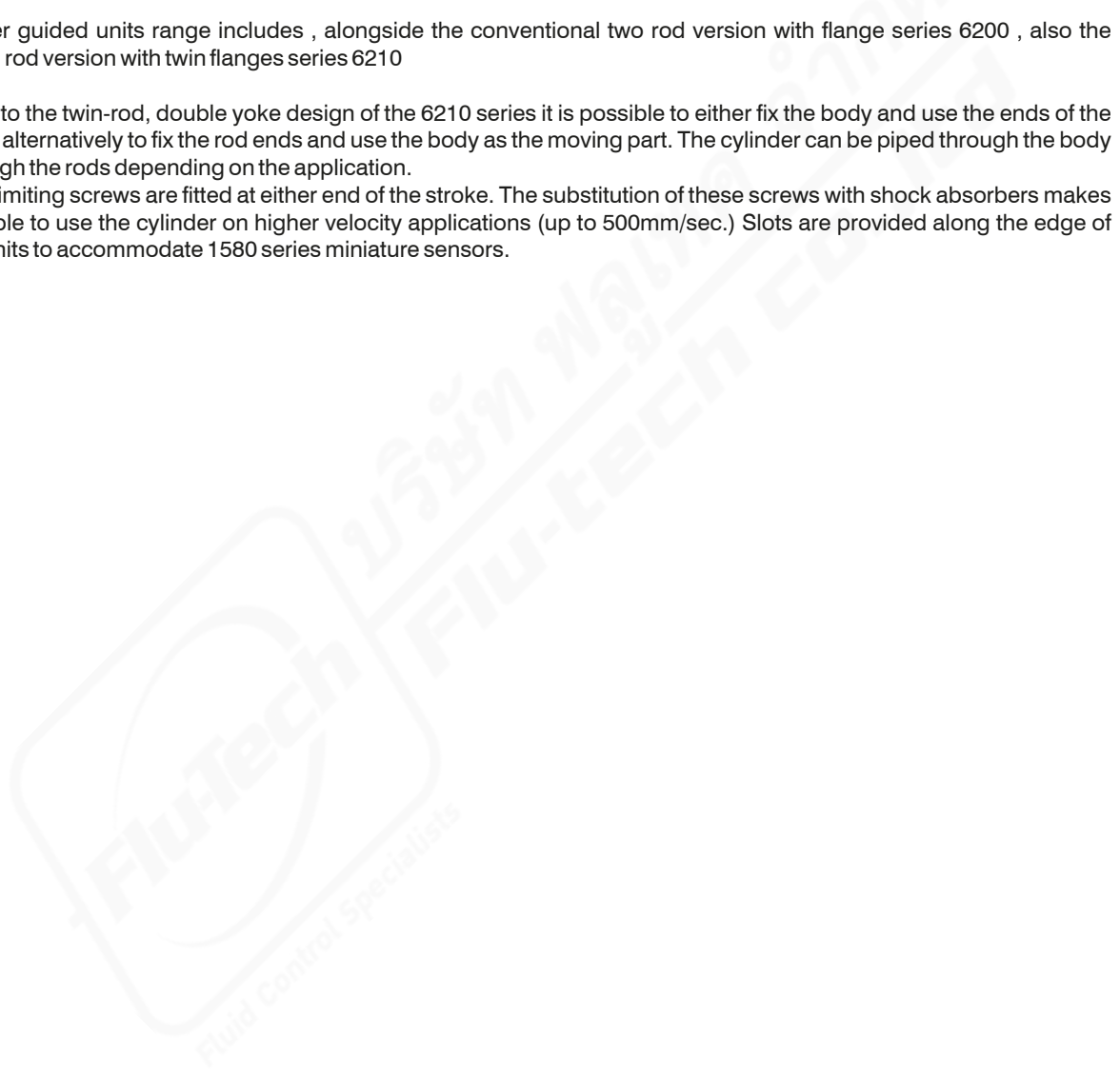

**FLU-TECH CO. LTD.**

**Email:** sales@flutech.co.th **Website:** <https://flutech.co.th>

**Tel:** 02-384-6060, 086-369-5871-3 **Fax:** 02-384-5701 **LINE OA:** @flutech.co.th

**Address (HQ):** 845/3-4, Moo 3, Theparak Rd., T. Theparak, A. Mueang Samut Prakan, Samut Prakan, 10270, Thailand



► Twin-rod slide units



Ordering code

6200.Ø.stroke.

- 10
- 15
- 20
- 25
- 32

- B = Control unit with bronze bush
- C = Control unit with bearing bush

Construction characteristics

Body	anodised aluminium
Rods	C43 chromed steel (control unit with bronze bush) tempered and chromed steel (control unit with bearing bush)
Piston	aluminium
Rod bushing	brass
End cap	anodised aluminium
Piston seal	oil resistant NBR rubber
Piston rod seal	PUR
Plate	anodised aluminium

Operational characteristics

Function	double acting
Fluid	Filtered air. No lubrication needed, if applied it shall be continuous.
Max. pressure	7 bar
Working temperature	-5°C - +70°C
Cushioning	elastic bumper

Standard strokes

Bore	Stroke														
	10	15	20	25	30	35	40	45	50	60	70	75	80	90	100
Ø10	●	●	●	●	●	●	●	●	●	●	●	●			
Ø15	●	●	●	●	●	●	●	●	●	●	●	●	●	●	●
Ø20	●	●	●	●	●	●	●	●	●	●	●	●	●	●	●
Ø25	●	●	●	●	●	●	●	●	●	●	●	●	●	●	●
Ø32	●	●	●	●	●	●	●	●	●	●	●	●	●	●	●



**Overall dimensions Ø10 - Ø15**

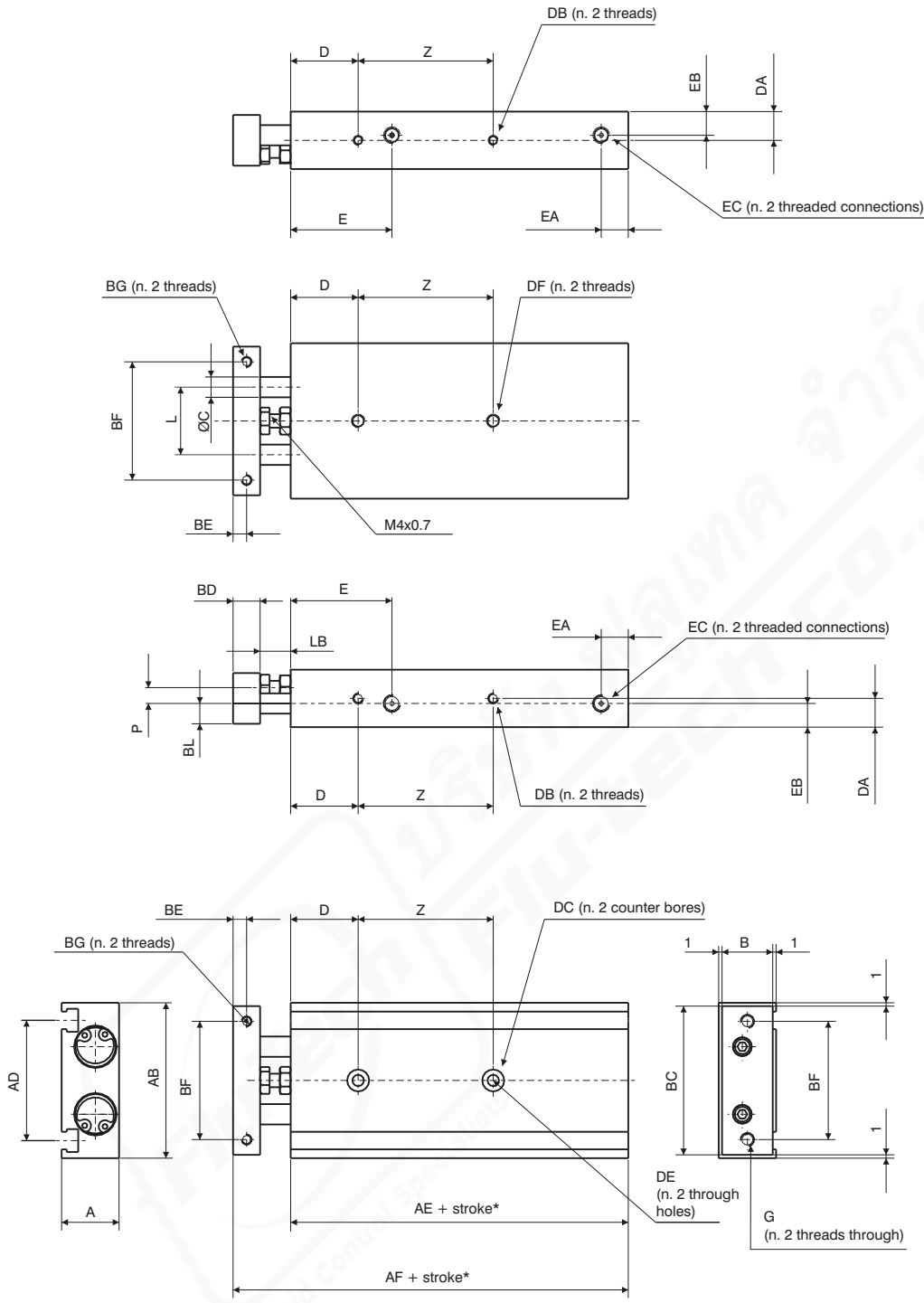

Bore		Ø10	Ø15	
<b>A</b>		17	20	
<b>AB</b>		46	58	
<b>AD</b>		35,6	48	
<b>AE</b>		55	60	
<b>AF</b>		72	79	
<b>B</b>		15	18	
<b>BC</b>		44	56	
<b>BD</b>		8	10	
<b>BE</b>		4	5	
<b>BF</b>		35	45	
<b>BG</b>		M3x0,5	M4x0,7	
	Useful depth	5	6	
<b>BL</b>		6	9	
<b>C</b>		6	8	
<b>D</b>		20	30	
<b>DA</b>		8,5	10	
<b>DB</b>		M3x0,5	M4x0,7	
	Useful depth	4,5	5	
	depth	6,5	8	
<b>DC</b>		3,3	4,4	
<b>DE</b>		3,4	4,3	
<b>DF</b>		M4x0,7	M5x0,8	
	Useful depth	7	8	
<b>E</b>		30	38,5	
<b>EA</b>		8	8	
<b>EB</b>		7	10	
<b>EC</b>		M5x0,8	M5x0,8	
	Useful depth	4,5	4,5	
<b>F</b>		M4x0,7	M4x0,7	
<b>G</b>		M4x0,7	M5x0,8	
<b>L</b>		20	25	
<b>LB</b>		9	9	
<b>P</b>		4,7	4,5	
<b>Z</b>	stroke	10 - 25	30	25
		30 - 50	40	35
		60 - 75	50	45
		80	-	45
		90-100	-	55

\*Dimensions only refer to the "standard stroke"

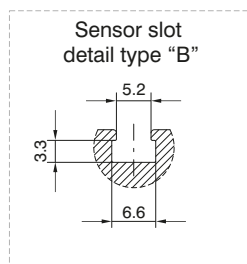

PNEUMATIC ACTUATION

Overall dimensions Ø20 - Ø25 - Ø32

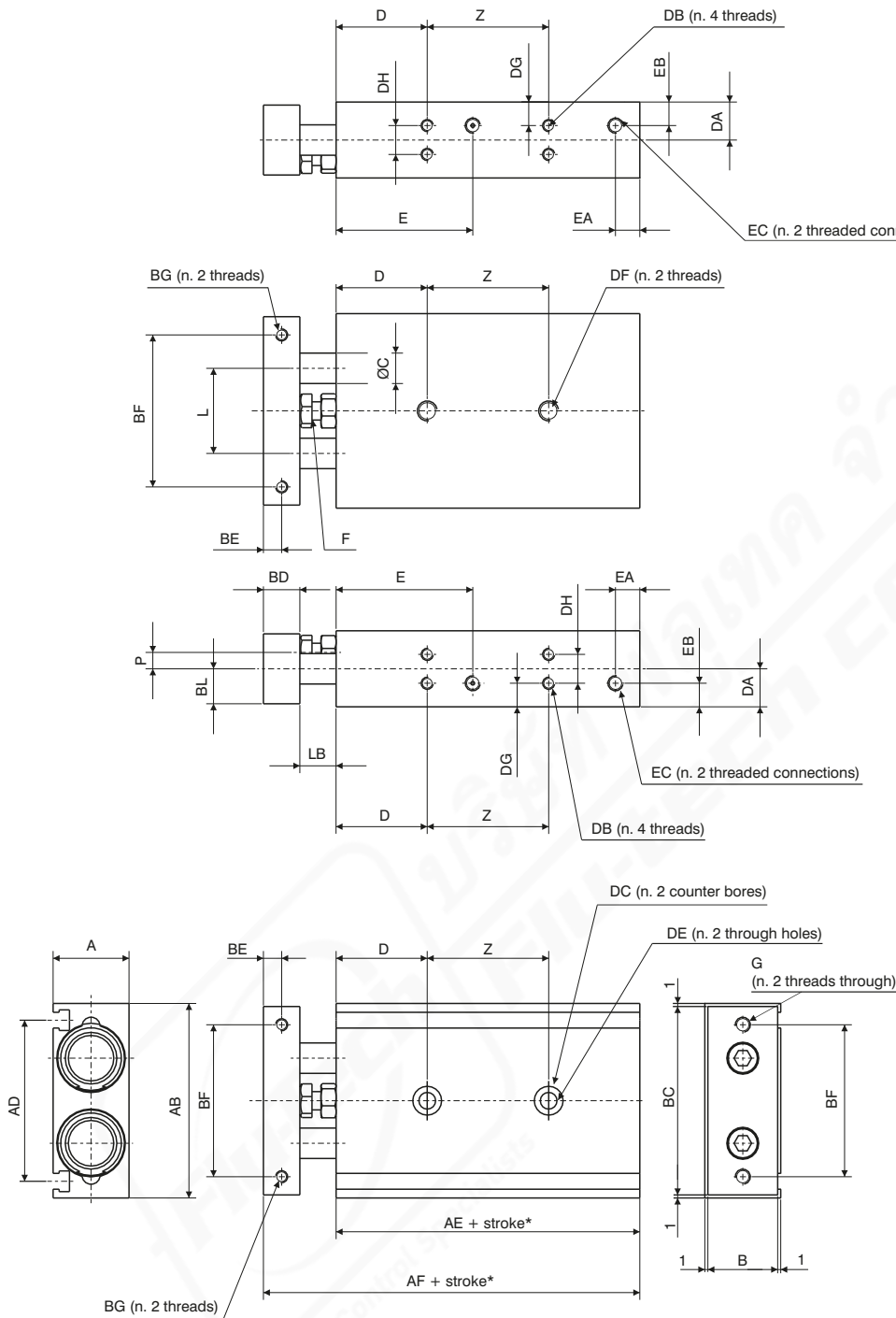

\*Dimensions only refer to the "standard stroke"

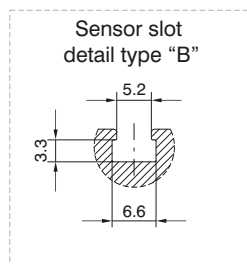

Bore	Ø20	Ø25	Ø32
<b>A</b>	25	30	38
<b>AB</b>	64	80	98
<b>AD</b>	53	64	76
<b>AE</b>	70	72	82
<b>AF</b>	94	96	112
<b>B</b>	23	28	36
<b>BC</b>	62	78	96
<b>BD</b>	12	12	16
<b>BE</b>	6	6	8
<b>BF</b>	50	60	75
<b>BG</b>	M4x0,7	M5x0,8	M5x0,8
Useful depth	6	7,5	8
<b>BL</b>	11,5	14	18
<b>C</b>	10	12	16
<b>D</b>	30	30	30
<b>DA</b>	12,5	15	19
<b>DB</b>	M4x0,7	M5x0,8	M5x0,8
Useful depth	6	7,5	7,5
<b>DC</b>	9,5	11	11
depth	5,3	6,3	6,3
<b>DE</b>	5,5	6,9	6,9
<b>DF</b>	M6x1	M8x1,25	M8x1,25
Useful depth	10	12	12
<b>DG</b>	7,75	8,5	9
<b>DH</b>	9,5	13	20
<b>E</b>	45	46	56
<b>EA</b>	8	9	10
<b>EB</b>	7,75	15	19
<b>EC</b>	M5x0,8	G1/8	G1/8
Useful depth	4,5	6,5	6,5
<b>F</b>	M6x1	M6x1	M8x1,25
<b>G</b>	M5x0,8	M6x1	M6x1
<b>L</b>	28	35	44
<b>LB</b>	12	12	14
<b>P</b>	5,4	7,8	12
<b>Z</b>			
stroke 10 - 25	30	30	40
stroke 30 - 50	40	40	50
stroke 60 - 100	60	60	70



Operating instructions

	Bore										
	Ø10		Ø15		Ø20		Ø25		Ø32		
Stroke	<b>Control unit with bronze bush</b>										<b>Weight g</b>
10	150	250	400	610	1150						
15	160	265	420	635	1190						
20	170	280	440	660	1230						
25	180	290	460	690	1275						
30	190	300	480	720	1320						
35	200	315	495	745	1360						
40	210	330	510	770	1400						
45	220	345	530	800	1450						
50	230	360	550	830	1490						
60	250	390	585	890	1580						
70	270	420	620	950	1665						
75	280	435	640	970	1710						
80		450	660	995	1755						
90		480	700	1060	1840						
100		510	740	1000	1930						
Stroke	<b>Control unit with bearing bush</b>										
10	160	270	430	620	1160						
15	165	285	445	645	1205						
20	170	300	460	670	1250						
25	180	310	480	700	1295						
30	190	320	500	730	1340						
35	200	335	515	755	1380						
40	210	350	530	780	1420						
45	220	365	550	810	1465						
50	230	380	570	840	1510						
60	250	410	605	895	1595						
70	270	440	640	955	1680						
75	280	455	660	980	1720						
80		470	680	1005	1765						
90		500	715	1065	1855						
100		530	750	1110	1940						
Working pressure	<b>Theoretical slide force</b>										
1 bar	16	10	35.5	25	63	47	98	75.5	161	120.5	
1.5 bar	23.5	15	53	38	94	62.5	147.5	113.5	241	181	
2 bar	31.5	20.0	70.5	50.5	125.5	94	196.5	151	321.5	241	
3 bar	47	30	106	75.5	188.5	141	294.5	227	482.5	362	
4 bar	63	40	141	101	251	188	393	302.5	643	482.5	
5 bar	78.5	50	176.5	126	314	236	491	378	804	603	
6 bar	94	60	212	151	377	283	589	453.5	965	723.5	
7 bar	110	70	247	176.5	440	330	687.5	529	1125.6	844	
	Out	In	Out	In	Out	In	Out	In	Out	In	

PNEUMATIC ACTUATION

Operating instructions

Possible loads

Control unit with bronze bush

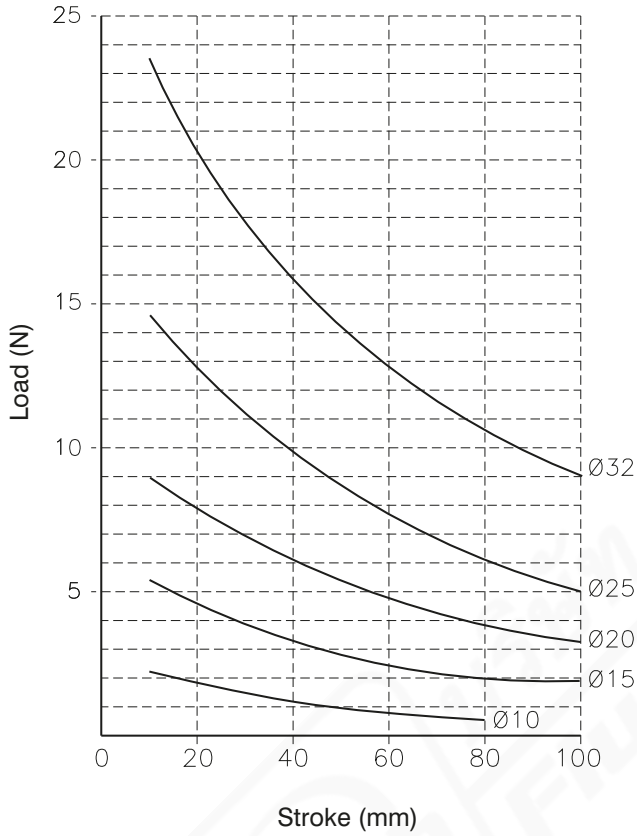

Control unit with bearing bush

