

FILTER FAILURE ALARM



FILTER FAILURE ALARM

WHAT IT DOES

- Continuous monitoring of fabric filter baghouses for broken bags
- Clear indication of system status through full color display
- Provides dual alarm relays (early warning and set maximum limit)
- Easy and user friendly system setting via external keypad
- Has a 4-20mA output to feed a PLC or other devices
- It's ATEX Zone 2 (Gas) and 22 (Dust) certified
- Acts as a preventive maintenance tool



PRODUCT DESCRIPTION

The Goyen | Mecair FFA provides you dependable and pragmatic filter monitoring through an easy setup external unit and clear, simple and language independent full-color LCD display. It features two alarm relays and a 4-20 mA output and can work in ATEX rated environments (II 3GD) and flu gas temperatures from -20°C to +240°C (-4°F to +464°F).

The FFA utilizes a unique probe electrification technology which provides much better performances than conventional DC triboelectric systems as well as alternative AC systems. This allows extending the velocity range over which the system has no cross sensitivity to changing velocity. Thanks to that technology, the FFA is also unaffected by build-up of particulate on the sensing rod, thus eliminating signal drift concerns. A charge signature is induced by particulates in the airstream interacting with the sensing rod. The FFA extracts a specific frequency band from the induced AC current signature and filter out the DC current generated by direct particle collisions. In order to reject signals falling outside a pre-defined frequency range, the so resulting signal is electronically filtered. Thanks to that, Goyen | Mecair filter failure alarms are less susceptible to changes in particle velocity and are not affected by any particulate contamination on the sensing rod.

Also this technology, not relying on particles colliding with the probe, is able to measure a more representative area of the stack and eliminate the need of long sensor probe rods. Thanks to the digital averaging of readings in combination with the alarm delay feature, by properly setting the delay period, the system will exclude short term signal increases associated with pulse cleaning of filters. This translates into a much lower likelihood of having false alarms.

OPERATIONAL RANGE

- Suitable for a wide range of dust collectors designs and configurations
- Dust level response: <math><1\text{mg}/\text{m}^3\text{ to }500\text{mg}/\text{m}^3\text{ (<math><0.028\text{ mg}/\text{ft}^3\text{ to }14\text{ mg}/\text{ft}^3\text{)}</math></math>
- Flue gas velocity from 4m/sec
- Flue gas temperature up to 240°C (464°F)
- Ambient temperature from -20°C to +50°C (-4°F to +122°F)
- Duct sizes from 0.5m
- Hazardous area ATEX II 3GD
- US-EPA MACT compliant

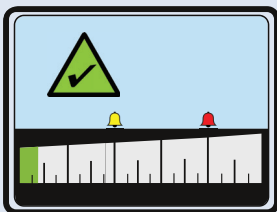

1

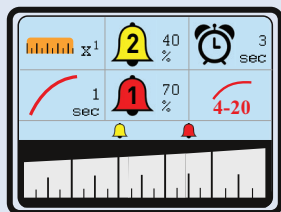

2

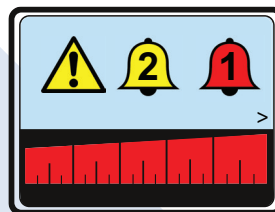

3

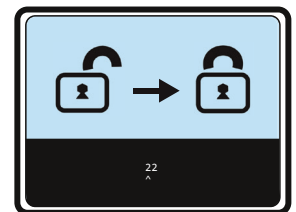

4

BENEFITS

- Reduce plant downtime thank to real-time emission monitoring for preventive maintenance
- Not language dependent, simple, easy setup and review of data
- Data averaging and alarm delay user selectable to avoid false alarms
- Two alarms levels can be independently set by the user, directly on the scale
- Instant notification of over-range to indicate leaking or broken bag failures
- To prevent tampering by unauthorized personnel, settings can be locked
- Suitable for all particles regardless of composition
- Extremely wide range of concentration and mass flow
- Seamless interface into industrial controls systems, such as PLC

FEATURES

- Icon menu (1)
- Alarm delay feature (1)
- Two independent alarms (2)
- Dust over-range icon (3)
- Security setting (4)
- Dependable 4-20 mA output
- Sensor sensitivity adjustment
- Unique probe electrification technology
- ATEX II 3GD compliant
- US-EPA MACT compliant

PROCESS AND APPLICATION CONDITIONS

Stack temperature range ^B	-20 to 240°C (-4 to 465°F)
SENSOR – KEY DATA	
Flue gas velocity	>4 m/s
Dust level response	<1 to 500 mg/m ³ (dependent upon application)
Application conditions	Suitable for measurement in non-condensing flue gases. <i>Note: not recommended for deployment downstream of ESPs, or in applications with water droplets or mist at monitoring point.</i>
Hazardous zone classification	ATEX Zones 2 (Gas) and 22 (Dust)
ENVIRONMENTAL INFORMATION	
Altitude category	max. 2,000m (6,500 ft.)

SENSOR SPECIFICATION

FILTER FAILURE ALARM MONITOR	
Sensor variant	Standard sensor: 0-240°C (up to 465°F)
Probe rod material	316 Stainless Steel, PTFE (insulator)
Weight	900g (2 lb), excl. rod
Cable entries	2x M16 cable glands (one blanked)
ENCLOSURE	
Ambient temperature range ^B	-20 to +50°C (-4 to 130°F)
Protection rating	IP65
Material	Die-cast aluminium LM6M (epoxy coated)
POWER REQUIREMENTS	
Power supply voltage	24 V DC (from the control unit)

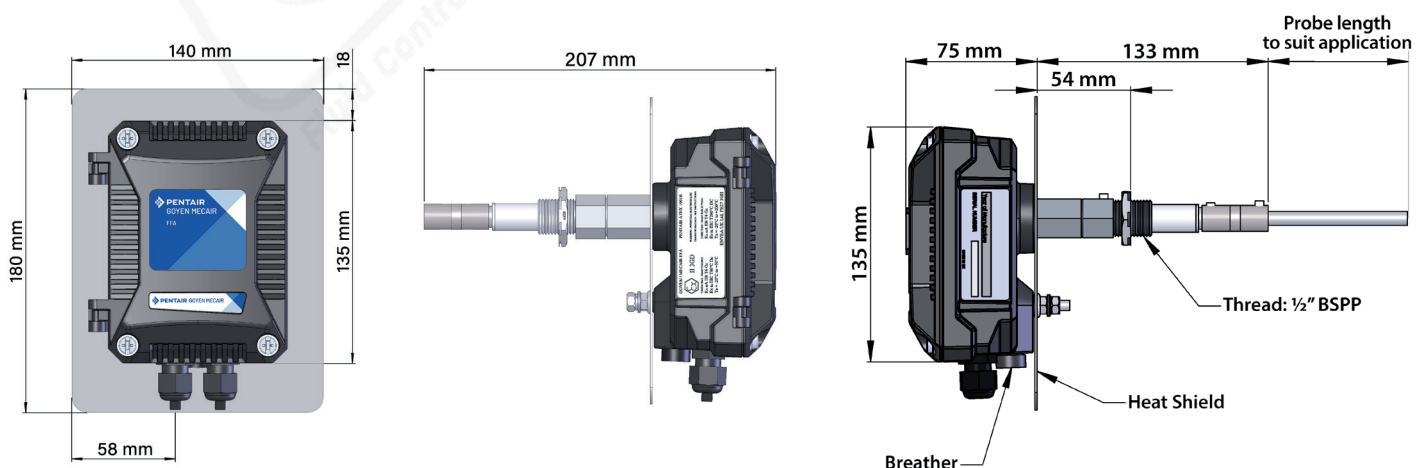

CONTROL UNIT SPECIFICATION

FFA CONTROL UNIT	
Controller type	FFA Controller
Weight	1.2 kg (2.7 lb)
Display	2.8" colour LCD, 4:3 ratio
ENCLOSURE	
Ambient temperature range	-20 to +50°C (-4 to 120°F)
Dimensions	W 200 × H 124 × 81 mm (8 × 5 × 3.2 in.), incl. glands
Protection rating	IP66
Material	Die-cast aluminium LM6M (epoxy coated)
Cable entries	3× M16 cable glands 1 × M20 cable gland (for mains power supply)
INPUTS/OUTPUTS	
Outputs	1 × Sensor connector (power/comms) 1 × 4–20 mA output: <ul style="list-style-type: none"> • SPC0, 250Ω • isolated 2 × Alarm rel ays: <ul style="list-style-type: none"> • solid state • volt-free SPC0 • current rating 0.5A @24V DC per contact
POWER REQUIREMENTS	
Power supply voltage	80–230V AC, 50/60 Hz

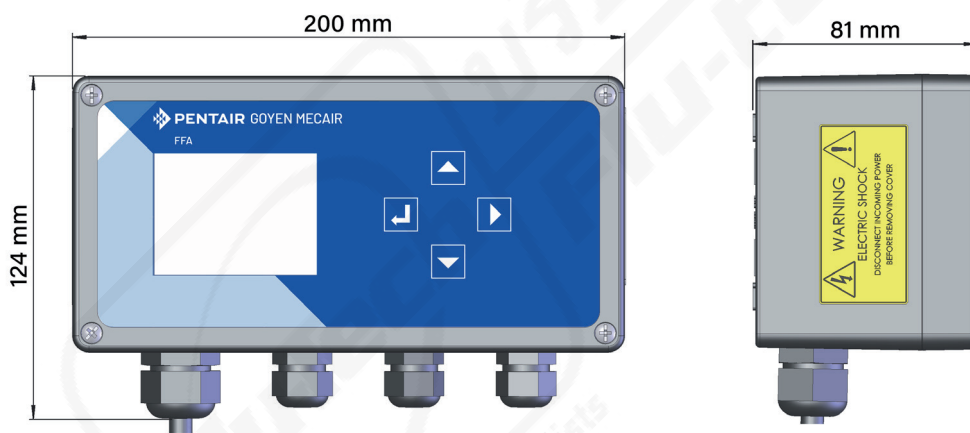

PROBE ROD LENGTH 300mm | 600mm | 1000mm

ORDERING CODES Please note that along with the FFA code you must always order either the F300, F600 or F1000 (respectively for the 300 mm long rod, the 600 mm long rod and the 1000 mm long rod)

NOTES Imperial temperatures given are nominal values



FLU-TECH CO. LTD.

Email: sales@flutech.co.th **Website:** https://flutech.co.th

Tel: 02-384-6060, 086-369-5871-3 **Fax:** 02-384-5701 **LINE OA:** @flutech.co.th

Address (HQ): 845/3-4, Moo 3, Theparak Rd., T. Theparak, A. Mueang Samut Prakan, Samut Prakan, 10270, Thailand